



1124

Hot Water Coil

UNITED STATES STOVE CO

EST^d 1869

CAUTION:

Read all instructions carefully before starting the installation.

1. Wash the water coil out with hot soapy water, then rinse. This will insure that no residues will be left inside the tube from the manufacturing process.
2. Measure the distance from center to center of the holes on the ends of the water tube. This measurement should be approximately 6 inches.
3. On the rear of the furnace, locate the holes for the coil installation. Remove the cover and gasket if equipped. On some furnace models, an access plate may need to be removed.
4. Figure 1 below shows how the water coil shall be fastened to the rear of the furnace. Following the diagram, run a nut all the way to the end of the threads on each leg.
5. Insert the coil through the holes from the inside and run a washer and a nut down each leg on the outside of the furnace. Before tightening the nuts completely, wrap a piece of the hi-temp rope gasket, provided with the kit, around each threaded leg in between the washer and firebox. Then finish tightening the nuts securely to insure an air tight seal.

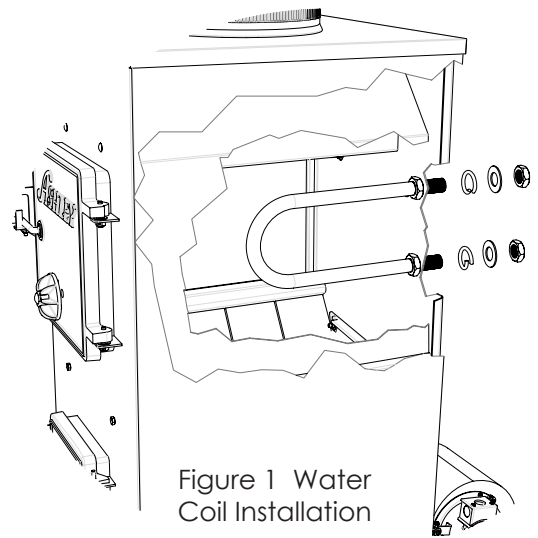

Figure 1 Water Coil Installation

The installation is now ready to be plumbed to the existing hot water system. Choose one of the three methods described in these instructions that will best suit your particular needs.

THERMO-SIPHON METHOD - FIGURE 2

This is the simplest and most economical method; however, the hot water heater must be 10 feet or less away from the furnace. The water inlet, where the temp/pressure relief valve is located, must be higher than the top leg of the coil. The hot water should be elevated, if necessary, to allow for proper thermo-siphon action (the method by which hot water will circulate automatically through the system).

1. Shut-off the hot water heater and the cold water supplying it. Drain the tank completely.
2. Remove the existing temp/pressure relief valve and discard. Install a short 3/4" nipple and tee (1) along with a new temp/pressure relief valve supplied with the kit.
3. Run 3/4" copper tubing along with the necessary fittings between the hot water heater and the top leg of the water coil. Install a 3/4" vent elbow and automatic "float type" air vent (2) in the high point of the line. Run 3/4" tubing from the release exit of the temp/pressure relief valve downward (3) so that the hot water may escape in the event of overheating.
4. Remove the drain valve at the bottom of the tank. Install a short 3/4" nipple and tee and re-install the drain valve to the tee (4). Run 3/4" copper tubing with the necessary fittings between the drain/tee combination and the lower leg of the water coil. After all of the connections have been completed, you may refill the tank. Turn on the hot water heater after the tank has completely filled with cold water.

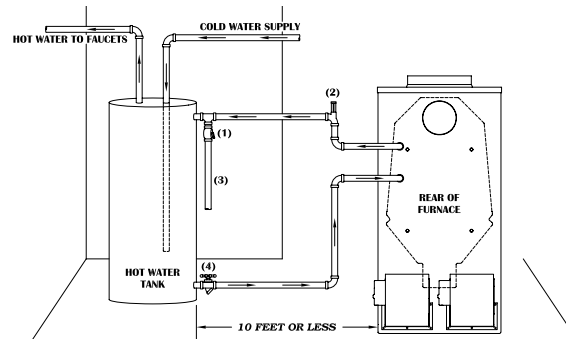

TEMPERING TANK METHOD - FIGURE 3

This method is used when the hot water heater is located more than ten(10) feet away from the furnace. The tempering tank is installed the same way as the hot water heater in the Thermo-Siphon Method, but acts as an additional holding tank for the existing hot water heater. The advantages of this method are that hot water capacity is greatly increased, there is no need for a circulating pump, and the tempering tank, during the summer months, allows cold water to set and be warmed before being drawn through the hot water heater, putting less of a demand on the heater. An old hot water tank without the electrical connections is ideal for this purpose; however, any holding tank will do if it is modified according to the drawing below.

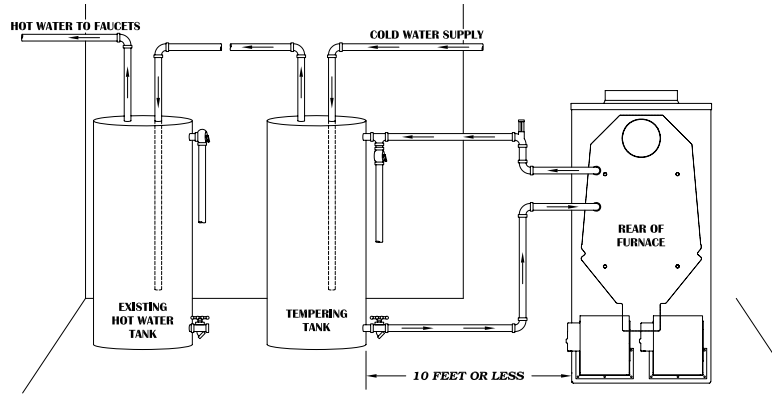

1. Following the instructions in the Thermo-Siphon method, connect the tempering tank to the water coil in the same manner. Make sure that it is located 10 feet or less away from the furnace. Note that the cold water supply is connected to the inlet on the tempering tank not the hot water heater. Be sure that the inlet pipe extends at least halfway to the bottom of the tempering tank.
2. Run 3/4" copper tubing from the tempering tank outlet to the marked cold water inlet on the existing hot water heater. We recommend replacing the existing temp/pressure relief valve with a new one, such as the one supplied in the kit.

CIRCULATING PUMP METHOD - FIGURE 4

This method is used when the hot water heater is more than ten(10) feet away from the furnace and a tempering tank is not available, or if the furnace is on a higher level than the hot water heater. In addition to a circulating pump, you will need an aquastat to thermostatically control it as the water temperature varies. A gate valve placed near the pump will allow for manual control of the water flow.

Shut-off the hot water heater and the cold water supply, then drain the tank completely.

Remove the existing temp/pressure relief valve from the water heater and replace it with a short 3/4" nipple and tee. Install a new valve and run an escape line downward as shown.

Remove the drain valve at the bottom of the tank. Install a short 3/4" nipple and tee, then re-install the drain valve to the tee.

Install a gate valve (3) leading away from the tee and a circulating pump as shown. Run 3/4" copper tubing from the circulating pump to the lower leg of the water coil.

Install a 3/4" tee to the top leg of the water coil with a new temp/pressure relief valve, supplied in the kit, coming out of the tee.

Run 3/4" copper tubing from the tee at the top leg of the coil and install an aquastat (6), wiring it to the circulating pump. Complete the 3/4" copper line by running it back to the tee at the top of the water heater, making sure to install a 3/4" vent elbow and an automatic air vent (7) at the high point of the line. The system is now ready to be refilled and the hot water heater turned back on.

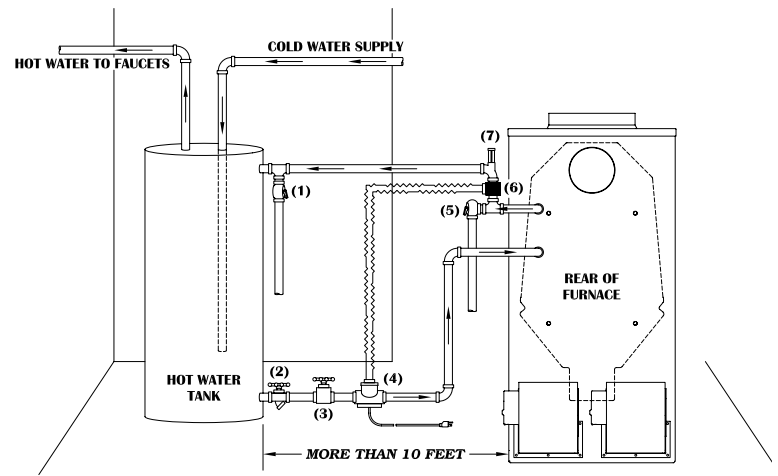

WARRANTY

United States Stove Company warrants the stainless steel water coil to be free from defects in material and workmanship for a period of Five(5) years from date of purchase. Should the stainless steel coil prove defective under warranty, contact U. S. Stove's Customer Service at (800)-750-2723 for a replacement, with proof of purchase. No warranty is given or implied covering incidental damages and expenses during the use of this product. Including personal injury and property damage.