

Installation/Operator's Manual

Model(s) 6041, 6041I

READ THIS ENTIRE MANUAL, THOROUGHLY, BEFORE ATTEMPTING TO INSTALL AND/OR BURN YOUR NEW AMERICAN HARVEST *MULTI-FUEL HEATER. FAILURE TO FOLLOW THESE INSTRUCTIONS MAY RESULT IN PROPERTY DAMAGE, BODILY INJURIES OR EVEN DEATH.

Safety Notice: If this heater is not properly installed, a house fire may result. For your safety, follow the installation directions. Contact local building or fire officials about restrictions and installation requirements peculiar to your area. Do Not Plug this appliance into an electrical outlet before reading and understanding all operations and always unplug the unit before attempting any work or maintenance. Do not connect this heater to any chimney flue already serving another appliance. Carefully observe and maintain all clearances to combustibles.

A note about fuel: Use only dried shelled corn with a moisture content of 15% or less (11 to 12% provides the best results); any pellet fuel used should have an ash content of 1% or less. If not, efficiency will suffer. This heater has successfully burned pellets with a 2-1/2% ash content, though less ash is preferred and more efficient.

Your American Harvest Multi-Fuel Heater operates on a negative pressure. Therefore, all venting connections (elbows, T-pipe) must be sealed and airtight.

i Use Hi-Temp silicone at each joint or connection.

*This heater is capable of burning wood, biomass pellets and a wide variety of grains, including corn, soybeans, cherry and olive pits, and all larger seeds.

SAVE THESE INSTRUCTIONS

UNITED STATES STOVE COMPANY GRANTS NO WARRANTY, IMPLIED OR STATED, FOR THE INSTALLATION OR MAINTENANCE OF THE HEATER AND ASSUMES NO RESPONSIBILITY FOR ANY CONSEQUENTIAL DAMAGE(S).

CALIFORNIA PROPOSITION 65 WARNING:

This product can expose you to chemicals including carbon monoxide, which is known to the State of California to cause cancer, birth defects and/or other reproductive harm. For more information, go to www.P65warnings.ca.gov

U.S. Environmental Protection Agency

Certified to comply with 2020 particulate emissions standards.

This unit is not intended to be used as a primary source of heat.



**UNITED STATES
STOVE CO**
EST[®] 1869

SPECIFICATIONS

You've purchased one of America's Finest Multi-fuel Burning Heaters. By heating with fuels such as corn and pellets, you're helping CONSERVE AMERICA'S ENERGY!

NOTE: YOUR UNIT MUST BE INSTALLED BY A QUALIFIED INSTALLER, such as an NFI (National Fireplace Institute) Certified Specialist

We strongly suggest installing smoke detectors in your home if not already installed. Initial burn off may cause slight smoke and odor the first few hours of operation. Perform initial burn outside if possible

United States Stove Company reserves the right to alter products, specifications and price without notice. Safety Tested & Listed to ASTM- E 1509, (UM) 84-HUD, by OMNI Test Laboratories, Inc., Portland, Oregon USA

Heating Capacity	1,000-2,000 Sq. Ft
Fuel Storage Capacity	60 Lbs.
Width	29 in./737mm
Height	24 in./610mm
Depth	28 in./711mm

- BTU output will vary, depending on the brand, type and quality of fuel and the moisture content. Consult your dealer for best results.
 - Based on post 1982 home construction, requiring 35 BTU/Hr per Sq. Ft.
- Remember, this heater should not be used as the only source of heat in the house. Power outages and neglect of periodic maintenance will result in a total loss of heat.



Report #: 19-495

This manual describes the installation and operation of the American Harvest and Hearth Focus, 6041, 6041I wood heater. This heater meets the 2020 U.S. Environmental Protection Agency's crib wood emission limits for wood heaters sold after May 15, 2020. Under specific test conditions this heater has been shown to deliver heat at rates ranging from 7,540 to 21,811 Btu/hr output. This heater achieved a particulate emissions rate of 1.28 g/hr when tested to method ASTM E 2779 / EPA Method 28R.

Note: Register your product on line at www.usstove.com. Save your receipt with your records for any claims.

60411 ASSEMBLY

DISCONNECT THE POWER CORD BEFORE SERVICING THIS HEATER

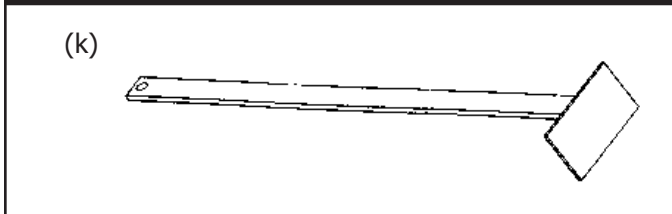
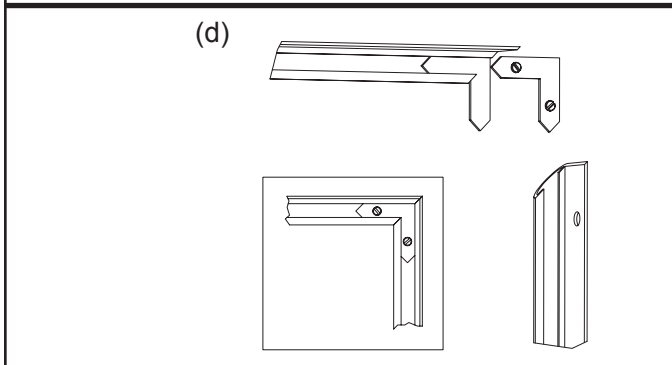
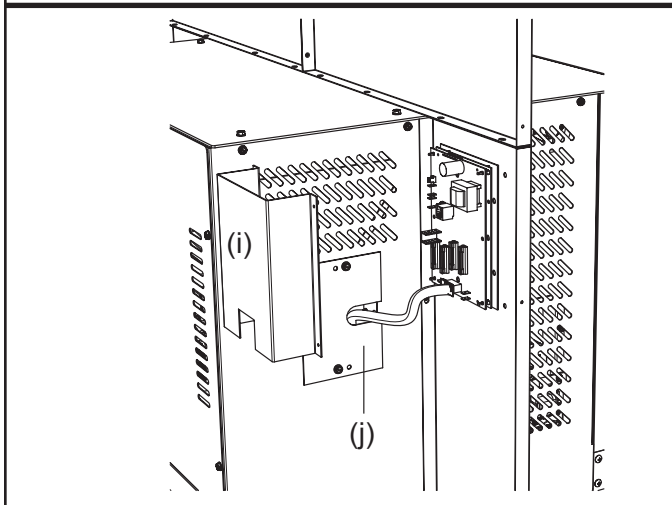
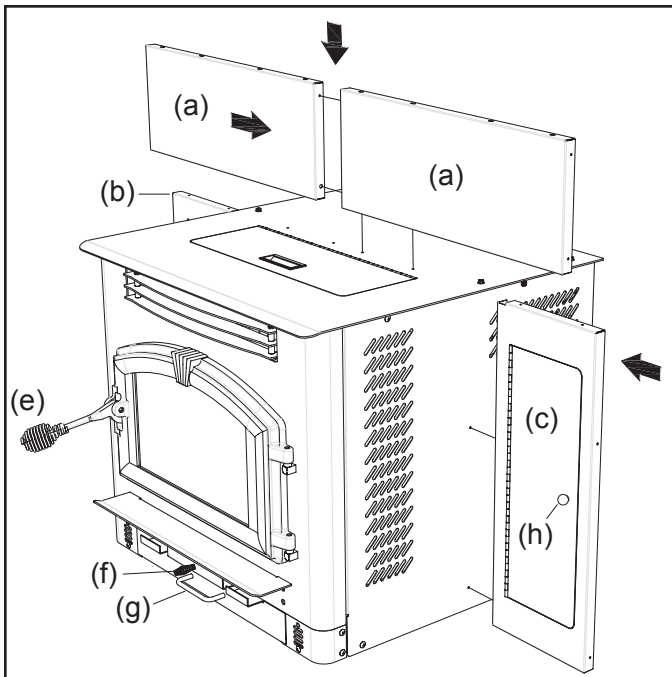

For the following assemblies, we suggest locating the unit near it's desired location. Depending on installation, you may want to connect the exhaust venting before installing the facade parts.

Assembly - Facade (Surround)

Remove contents from packaging and make sure you have all components:

- (2) Top Facade (a)
- (1) Left Side Facade (b)
- (1) Right Side Facade (c)
- (4 pieces) Facade Trim Kit (d)
- (1) Feed Door Spring Handle (e)
- (1) Damper Spring Handle (f)
- (1) Ash Pan "U" shaped Handle (g)
- (1) Access Door Knob (h)
- (1) PCB Cover (i)
- (1) Panel Cover (j)
- (1) Auger (in ash pan)
- (1) Power Cord
- (1) Burnpot Poker (k)

Mounting Hardware

Start by mounting either the left or right side facade pieces to the unit using four(4) of the supplied #10 x 1/2 screws. Then put the two(2) top facade pieces together with two(2) of the #10 x 1/2 screws provided. Attach the top facade assembly to the unit with eight(8) of the same screws.

Control Board (PCB) Re-location

Remove the left side front panel from the unit. While holding the PCB with one hand, remove the two(2) hex head screws holding the board in place. It is not necessary to unplug the PCB cable. Route the board and cable through the opening and mount it to the Left Facade using two of the #10 x 1/2 phillips head screws provided. Then attach the PCB cover to the back of the facade covering the board. Next, use the two hex head screws removed earlier and mount the cover panel over the opening where the PCB was located. See illustration to the left.

Facade Trim

Remove trim from shipping tube. There should be one(1) left side, one(1) right side, two(2) top pieces, and mounting hardware. Using one blank corner key and one corner key with set screws, assemble the left trim and one of the top pieces together. As illustrated, place the blank key behind the key with the set screws. Adjust corners and tighten set screws. Repeat this for the right side. Before removing tape, place trim assembly against facade to get an idea of how it is to be mounted. Remove the strip from the adhesive and carefully secure the trim in place by firmly pressing it to the facade.

Burnpot Poker

The burnpot poker may be used several ways. It is used primarily as a fuel-loading assistant to help push the fuel to the rear of the hopper for maximum fueling. It may also be used for cleaning of ashes or removal of clinkers.

COMPONENT LOCATION

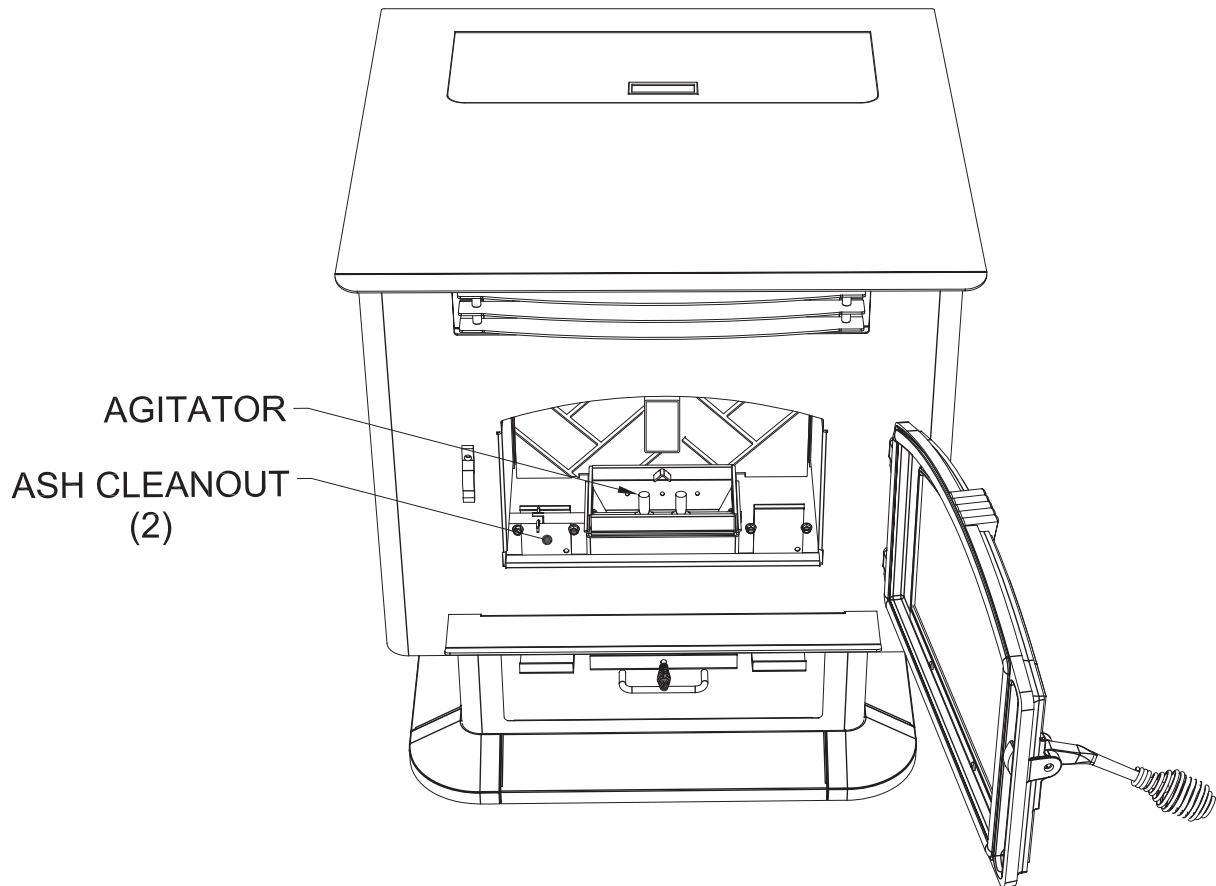
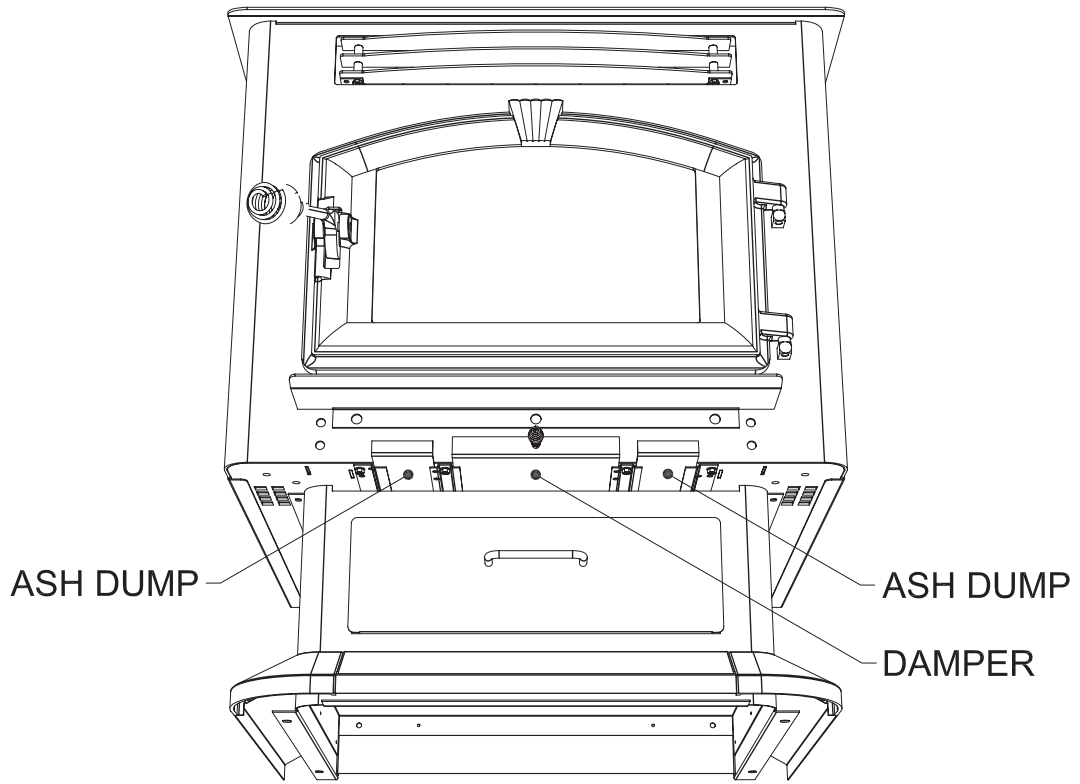

SAFETY STEPS

IMPORTANT

Proper installation of this heater is necessary for safe and efficient operation. Installing this product improperly may result in a house fire and personal injury. All applicable building codes for your location must be followed. In areas where building codes require additional steps to the installation of this product not included in this manual, the building codes will take precedent and must be followed. Contact your local building inspector to obtain any necessary permits or inspection guidelines before installing the product.

- This heater is designed to burn dry shelled corn, cherry pits, or pelletized fuel such as wood and biomass pellets. The burning of other solid fuels such as cord wood or wood chips in this heater is not permitted.
- This product requires simple periodic maintenance for proper operation and long life of the heater. Read and follow the maintenance schedule closely.
- **DISCONNECT THE POWER CORD BEFORE SERVICING THIS HEATER!**
- **A power surge protector is required.** The unit must be plugged into a **grounded** 110-volt power source. Circuit Boards are very expensive - protect yours!
- Always route the power cord away from the unit. Do not route cord in foot traffic areas. Do not pinch cord under furniture. Do not route the cord across the exhaust pipe.
- A working smoke detector must be installed in the same room as this product.
- Flammable or explosive liquids such as gasoline, naphtha, alcohol, lighter fluid, or engine oil must **NEVER** be used in or around this heater. These liquids must be stored well away from this heater as the open flame in the burner chamber could ignite the fumes of such liquids.
- The moving parts of this heater are propelled by high torque electric motors. The Auger and Fuel Agitator can cause severe injury to body parts that may get near them. Keep all body parts away from the Auger and Fuel Agitator while the heater is plugged into an electrical outlet. These moving parts may begin to move at any time while the heater is plugged in.
- According to HUD requirements, when installed in a mobile home, this heater must be grounded directly to the steel chassis of the mobile home and bolted to the floor. Direct air access must be provided - Use 69FAK Fresh Air Kit
- This heater is not intended for use in commercial installations.
- Do not connect this heater to "B" vent. **Use UL Listed Pell Vent ONLY!**
- Do not elevate the fire by use of grate or any other means other than the supplied burnpot.

BURNING SOLID FUELS

Ashes will have to be removed from the heater for proper operation. See cleaning procedure.

Your Multi-fuel heater, due to the nature of solid fuels, will require brief periodic attention. Please do not expect to light your heater and walk away from it. A few moments of adjustment and cleaning is an important part of burning solid fuels, due to the vast differences in fuel, humidity and outside temperature.

The Multi-fuel heater has been designed to burn dry shelled corn, wood pellets and other pelletized fuels that meet the Pellet Fuel Institute (PFI) standards.

SHELLED CORN (DRY, PREFERABLY CORN WITH 11- 12% MOISTURE CONTENT)

- **Corn must contain less than 14% moisture content.** Wet corn will rapidly deteriorate heater components, reduce efficiency and void all warranties. Purchase a moisture tester if in doubt.
- Corn must be clean and free from debris. Never burn corn right from the field. Damage caused by dirty corn is not covered by the product warranty. Ask for clean **filtered** bagged corn only. Stalk parts, excessive fines and cob remnants will clog the auger. Check your corn for foreign objects.
- **NEVER BURN SEED CORN IN YOUR HEATER.** Seed corn is treated with chemical pesticides that are harmful or fatal if swallowed, therefore, seed corn is dangerous to have in the house, especially where children can reach it.
- Never burn "Deer Corn." It frequently contains molasses, sugars and salts.
- Store your corn supply in a dry place and keep bags or container sealed to prevent your corn from absorbing excess moisture. Test the moisture content periodically to ensure the proper dryness.
- There are many varieties of corn grown around the world. Each variety has unique characteristics including the shape and size of the kernel. Your heater will burn more consistently with a small to midsize kernel corn. If the kernel size of the corn varies greatly or if you switch sources frequently, you will get a less consistent burn. Therefore, purchasing corn from the same source will help achieve a more consistent burn. **DO NOT USE CORN WITH A HIGH WAX CONTENT!**

WOOD AND BIOMASS PELLETS

- As with corn, be consistent in your pellet supplier. Pellets will vary in content and burn characteristics from supplier to supplier. A consistent supply of pellets will result in a more consistent and efficient burn.
- Check your pellets for foreign objects. Your heater warranty will not cover damage done to your heater due to foreign objects in the fuel supply.
- **Store your pellets in a dry place to prevent them from absorbing added moisture.**
- To decrease sawdust buildup, the hopper and auger tube will need to be vacuumed out after every 6-8 bags of pellets or more often if the pellets are poor quality. The hopper should be empty of fuel when this is performed. You may have to screen each bag of pellets if sawdust becomes a problem.
- Wood Pellets vary in size and ash content from less than 1% to 3% or more. Your heater will burn more efficiently with small to midsize pellets (Preferred pellet size is 1/4" diameter x 1" length). Low ash content pellets will allow you to burn the heater longer between cleaning. Only wood pellets manufactured to the Pellet Fuel Institute (P.F.I) standard for residential pellets fuels are recommended. Performance will suffer if nonstandard pellets are used. Consult your local stove dealer for more information on approved wood pellet fuel.

CAUTION: DO NOT PLACE SUCH FUELS WITHIN THE SPACE HEATER'S INSTALLATION CLEARANCES OR WITHIN THE SPACE REQUIRED FOR FUELING AND ASH REMOVAL.

INSTALLATION REQUIREMENTS

FLOOR PROTECTION

The Multifuel Heater may be installed on a combustible floor, with proper floor protection, or on a masonry hearth. The hearth or noncombustible floor protector must extend a minimum of 6" (152mm) in front and 6" (152mm) from each side of the unit.

CLEARANCES TO COMBUSTIBLES 6041

The heater must be installed with the following minimum clearances to side and back wall combustible materials.

NOTE: These are minimum clearances to combustible walls established by the testing lab.

		in	mm
PARALLEL	A Sidewall to Top Edge of Unit	8	203
	B Sidewall to Flue	13	330
	C Backwall to Flue	3	75
	D Backwall to Unit	9	228
CORNER	E Adjacent Wall to Flue	3	75
	F Adjacent Wall to Unit	4	100

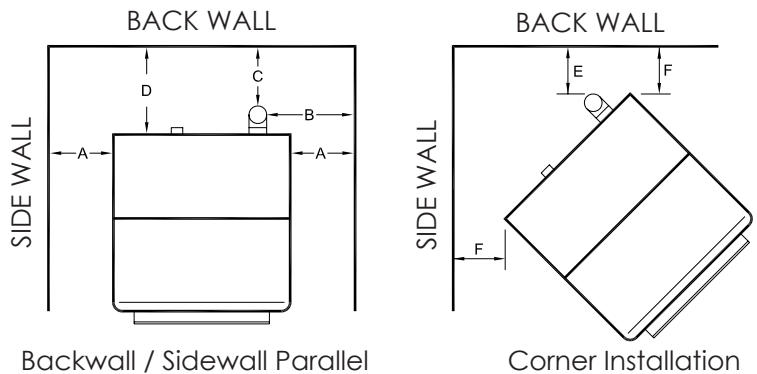

NOTE: Allow sufficient space to remove the left and right side panels for maintenance purposes.

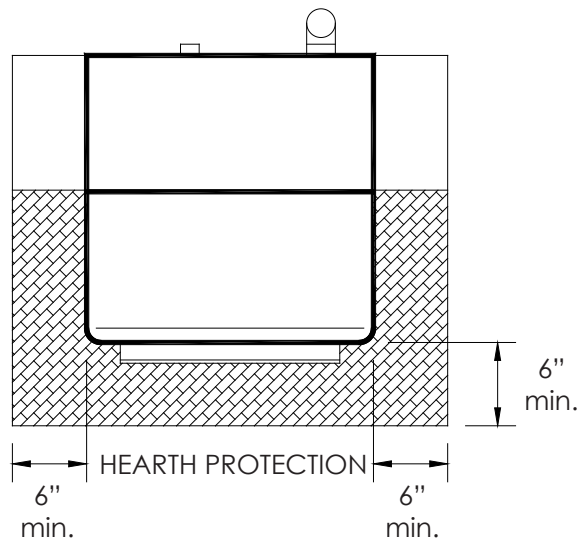

These clearances must be maintained.

CLEARANCES TO COMBUSTIBLES 60411

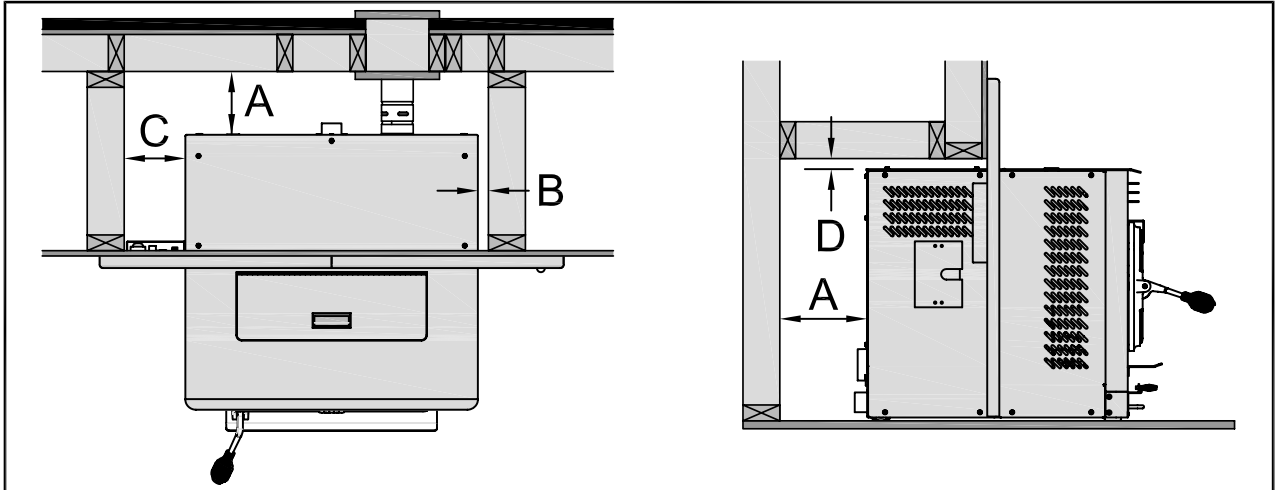

AS A BUILT-IN

KEY		INCHES
A	BACK OF UNIT TO WALL	6
B	RIGHT SIDE OF UNIT TO WALL	1
C	LEFT SIDE OF UNIT TO WALL	6
D	TOP OF UNIT TO WALL	1

EXTERNAL CLEARANCE TO COMBUSTIBLES

KEY		INCHES
A	FLOOR PROTECTOR EDGE TO FRONT OF UNIT	6
B	FLOOR PROTECTOR EDGE TO SIDE OF UNIT	6
C	LEFT SIDE OF UNIT TO WALL	8
D	FLOOR TO MANTEL	53

MINIMUM OPENING FOR MASONRY AND FACTORY-BUILT FIREPLACES

KEY		INCHES
A	HEIGHT	24
B	WIDTH	40
C	DEPTH	20

GUIDELINES FOR EXHAUST VENTING SYSTEMS DESIGN

IMPORTANCE OF PROPER DRAFT

Draft is the force which moves air from the appliance up through the chimney. The amount of draft in your chimney depends on the length of the chimney, local geography, nearby obstructions and other factors. Too much draft may cause excessive temperatures in the appliance. Inadequate draft may cause backpuffing into the room and 'plugging' of the chimney. Inadequate draft will cause the appliance to leak smoke into the room through appliance and chimney connector joints. An uncontrollable burn or excessive temperature indicates excessive draft. Take into account the chimney's location to ensure it is not too close to neighbors or in a valley which may cause unhealthy or nuisance conditions. It is recommended that only an authorized installer install your multi-fuel heater, preferably an NFI certified specialist. The following installation guidelines must be followed to ensure conformity with both the safety listing of this heater and to local building codes.

INSTALL VENT AT CLEARANCES SPECIFIED BY THE VENT MANUFACTURER.

- A UL listed 3" or 4" type "PL" pellet vent exhaust system must be used for installation and attached to the pipe connector provided on the back of the heater. Use a 3" to 4" adapter for 4" pipe. A cap must be used at the termination of type "L" vent chimneys. 4" PL is required for elevations above 2,500 feet above sea level.
- Do not terminate vent in any enclosed or semi-enclosed area, such as; carports, garage, attic, crawl space, under a sundeck or porch, narrow walkway or close area, or any location that can build up a concentration of fumes such as a stairwell, covered breezeway etc.
- Vent surfaces can get hot enough to cause burns if touched by children. Noncombustible shielding or guards may be required.
- Do not install a flue damper in the exhaust vent of this unit.
- Termination must exhaust above air inlet elevation. Installation MUST include three (3) vertical feet of pellet vent pipe. This will create some natural draft to prevent the possibility of smoke or odor during appliance shutdown and to keep exhaust from causing a nuisance or hazard from exposing people or shrubs to high temperatures. Do not connect this unit to a chimney flue serving another appliance. Do not connect directly to a masonry chimney.
- The installation must include a cleanout tee to enable collection of fly ash and to permit periodic cleaning of the exhaust system. 90° elbows accumulate fly ash and soot thereby reducing exhaust flow and performance of the heater. Each elbow or tee reduces draft potential by 30% to 50%. Use no more than 180 degrees of elbows (two 90-degree elbows, or two 45-degree and one 90-degree elbow, etc.) and one cleanout tee to maintain adequate draft. Cleanout tees and elbows should not be connected to the rear of the unit unless a 3-inch adapter is used.
- Total length of horizontal vent must not exceed 48"(4ft.)/1,200mm. The maximum recommended vertical venting height is 12-feet for 3-inch type "PL" vent. For venting higher than 12-feet, 4-inch "PL" vent must be used. All joints in the vent system must be fastened by at least 3 screws, and all joints must be sealed with RTV silicone sealer to be airtight.
- The area where the vent pipe penetrates to the exterior of the home must be sealed with silicone or other means to maintain the vapor barrier between the exterior and the interior of the home.

NOTE: These are guidelines only. Proper venting is accomplished by design and necessary requirements. In most installations 3 inch diameter venting is adequate. If it does not vent properly you will have to change it to 4 inches. You should not exceed 4 inch diameter venting.

DO NOT CONNECT TO ANY AIR DISTRIBUTION DUCT OR SYSTEM

VENT TERMINATION CLEARANCES

- A. Min. 4-ft clearance below or beside any door or window that opens.
- B. Min. 1-ft clearance above any door or window that opens.
- C. Min. 3-ft clearance from any adjacent building.
- D. Min. 7-ft clearance from any grade when adjacent to public walkways.
- E. Min. 2-ft clearance above any grass, plants, or other combustible materials.
- F. Min. 3-ft clearance from a forced air intake of any appliance.
- G. Min. 2-ft clearance below eaves or overhang.
- H. Min. 1-ft clearance horizontally from combustible wall.
- I. Must be a minimum of 36-inches above the roof and 24-inches above the highest point or the roof within 10-feet.

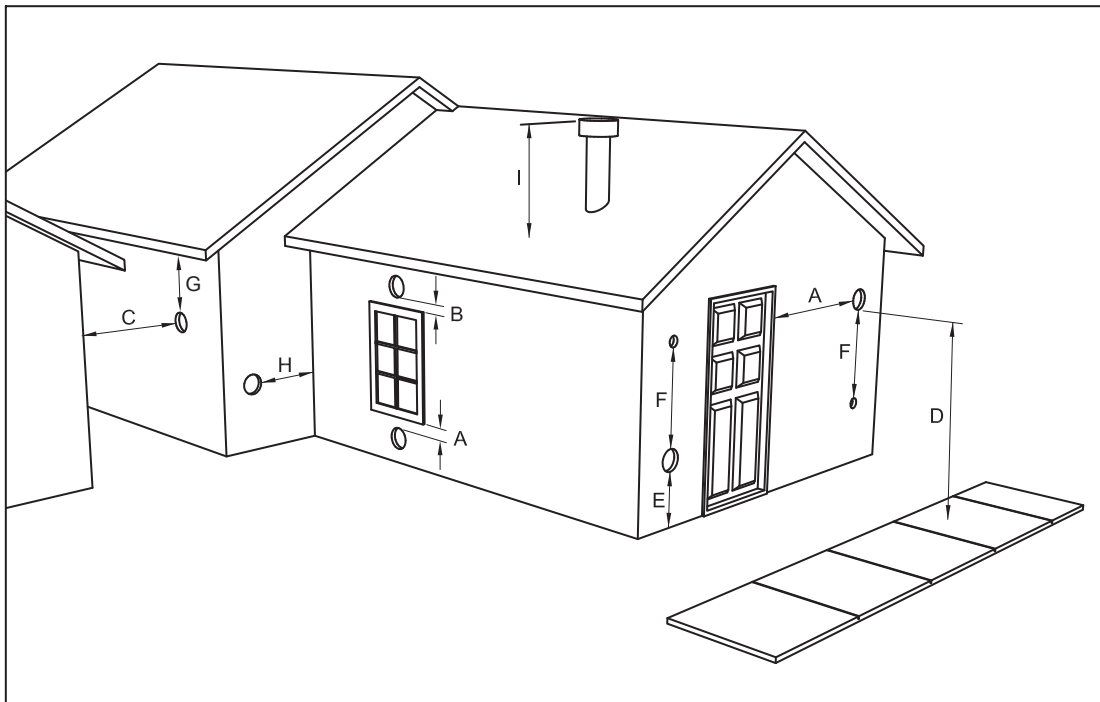

DESIGN GUIDELINES FOR OUTSIDE COMBUSTION AIR CONNECTION

1. For installations with horizontal through-the-wall exhaust, it is strongly recommended that the heater combustion air be connected to the outside. If the home is newer or has been tightly insulated, it is required to install outside combustion air.

2. Connection to outside the house is **REQUIRED** for mobile home installations. We strongly urge use of the 69FAK Fresh Air Kit.

3. Only noncombustible pipe 2 inches (or greater) in diameter is approved to use for outside air connections (straight or flexible). PVC pipe is **NOT** approved and should **NEVER** be used.

4. If the air inlet is connected to the outside, it **MUST** be terminated with a vertical 90-degree bend (down) or with a wind hood. Failure to do so could result in a burn back during high winds blowing directly up the air inlet during a simultaneous power failure (see diagram above).

5. Blockage, excessive length, or extra bends in the air intake pipe will starve the heater of combustion air. A 90-degree bend is equivalent in restriction to approximately 30 inches of straight inlet pipe.

CAUTION: The operation of exhaust fans such as bath room fans, attic fans, etc. might starve the heater of combustible air creating a negative pressure in the room. Provide adequate ventilation in the room accompanying the heater. If not, the pressure switch may shut off operation of the heater. (Due to negative pressure)

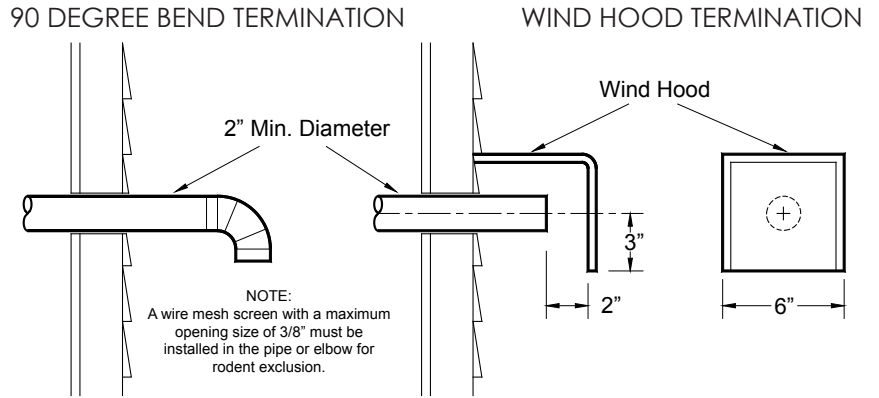

INSTALLATION CONFIGURATIONS

The Multifuel Heater Model 6041 may be installed as a freestanding unit.

The Multifuel Heater Model 6041I insert may be installed as follows:

1. In a pre-fab firebox (Factory Built)
2. In an existing masonry fireplace
3. As a build-in

MOBILE HOME INSTALLATION REQUIREMENTS

IN ADDITION TO THE STANDARD INSTALLATION INSTRUCTION, THE FOLLOWING REQUIREMENTS ARE MANDATORY FOR INSTALLATION IN A MOBILE HOME:

WARNING: DO NOT INSTALL IN SLEEPING ROOM

1. Heater must be permanently bolted to the floor. Remove the Base Trim and bolt thru the base flange.
2. Heater must have permanent outside air source. (69FAK)
3. Heater must be permanently electrically grounded to the steel chassis of the mobile home.
4. All vertical chimney vent must have wall supports.
5. All exhaust systems must have a spark arrester.

CAUTION: The structural integrity of the mobile home floor, wall and ceiling/ROOF must be maintained. Check with your local building official as other codes may apply.

Note: Always check dimensions on unit before cutting hole in wall

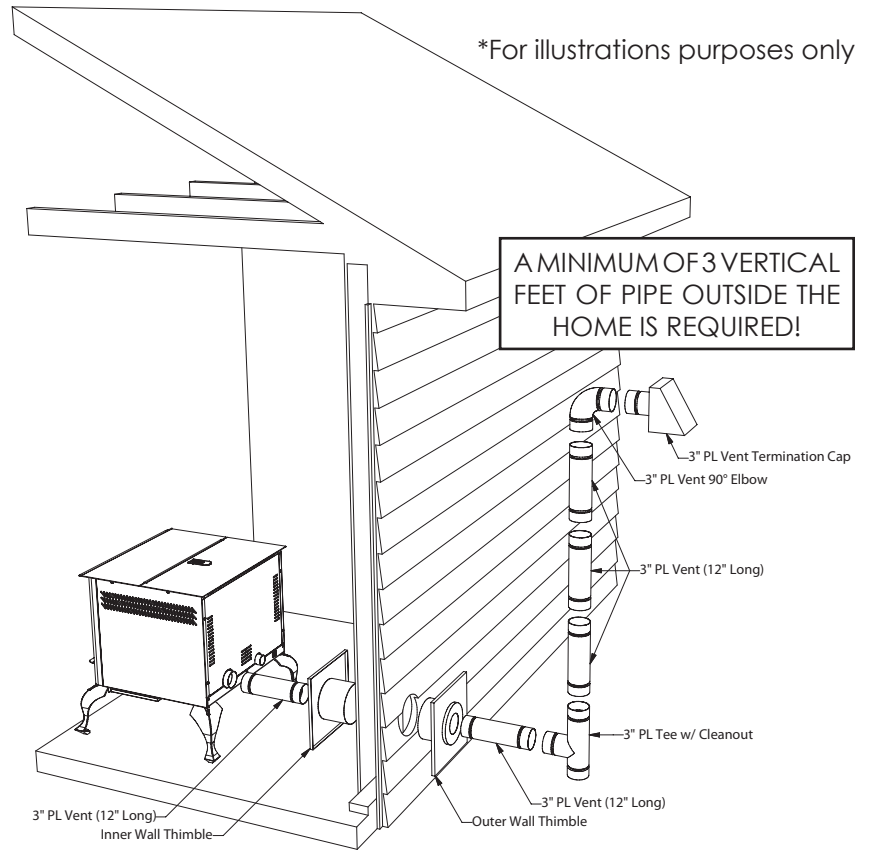

THROUGH THE WALL, VERTICAL PIPE INSTALLATION WITH TERMINATION CAP

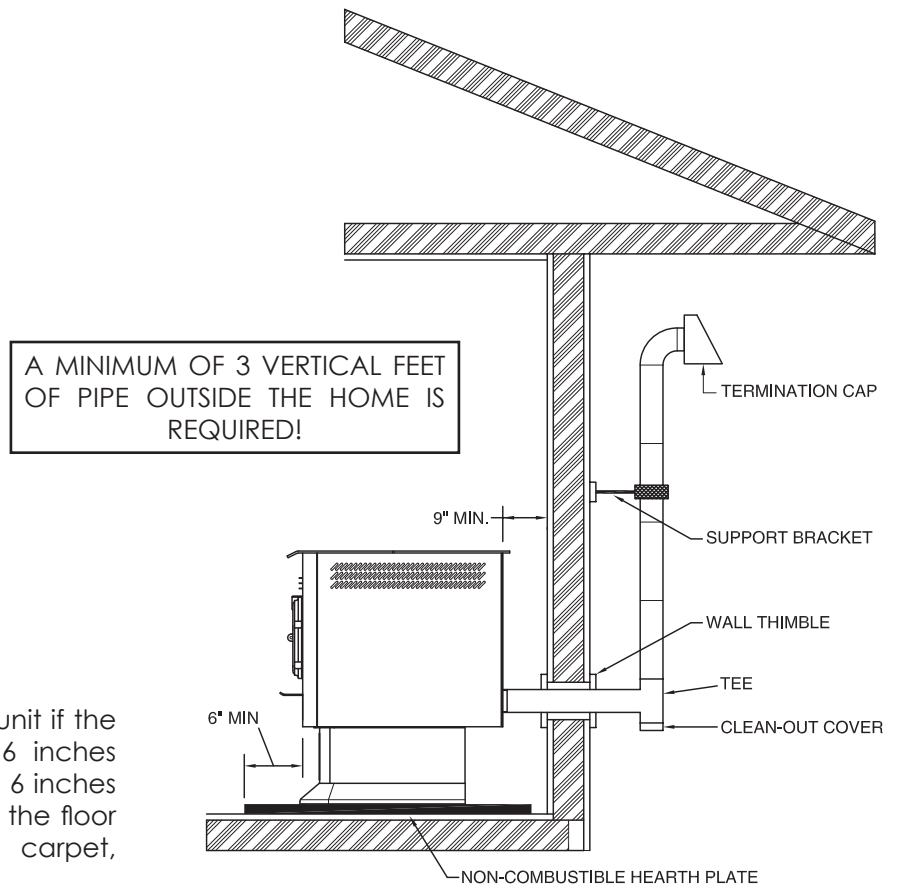

The Hearth Pad is not required under the unit if the floor is noncombustible but is required 6 inches (152mm) beyond the front of the unit and 6 inches (152mm) beyond each side of the door if the floor is a combustible floor. (wood flooring, carpet, linoleum, etc.)

DESIGN GUIDELINES FOR 6041I INSERT INSTALLATION

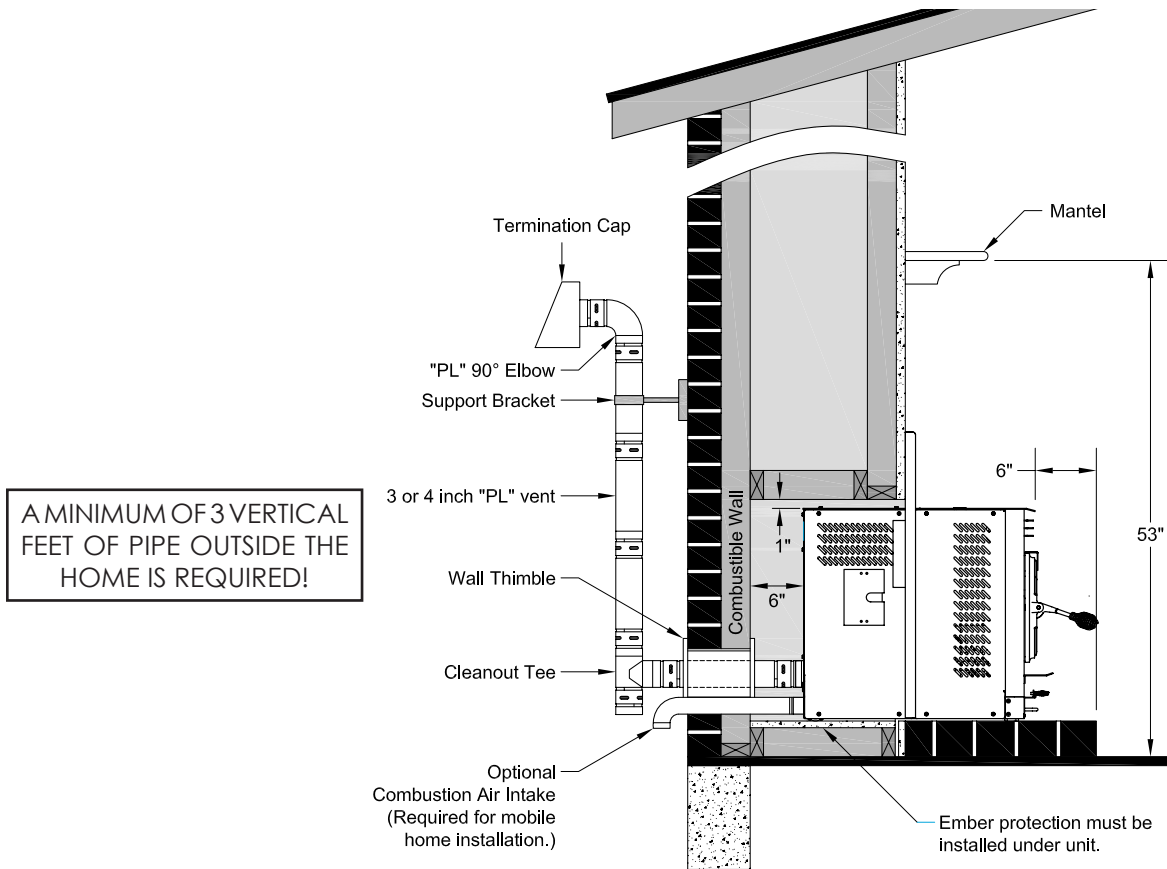

INSTALLATION AS A BUILT-IN FIREPLACE

A continuous sheet of non-combustible floor protection must be installed underneath the unit to prevent the possibility of embers falling through to the combustible floor. If the floor beneath the unit is of non-combustible material, the protector is not required. See the "Clearance to Combustibles" section of this manual for installation clearances.

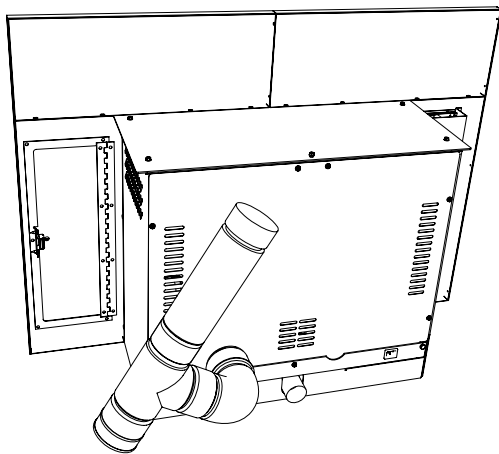

ALTERNATIVE EXHAUST VENTING

Depending on your installation, you might consider routing your cleanout tee as illustrated below for ease of cleaning. The access panel in the right side facade allows you to reach the tee from the front side of the unit if venting is assembled as shown. The cleanout tee is attached to a 90° elbow mounted to the unit then rotated at approx. 15-20 degrees. A 12 inch section of "PL" vent is connected to reach the top of the unit to which a flexible pipe may be attached for further termination through a chimney. Clearance to combustibles must be considered if this installation is chosen. A distance of 3 inches must be maintained from the exhaust vent to any combustible material.

DESIGN GUIDELINES FOR 6041I INSERT INSTALLATION

INSTALLATION INTO A MASONRY FIREPLACE

When installing into a masonry fireplace, DO NOT remove any bricks or masonry, with the following exception: masonry or steel, including the damper plate, may be removed from the smoke shelf and adjacent damper frame, if necessary, to accommodate a chimney liner. Do this only if their removal will not weaken the structure of the fireplace or the chimney, and will not reduce protection for combustibles to less than that required by national building codes. Installation must include a chimney liner (4" Pell Vent "PL" Piping) that extends the full height of the chimney and meets type HT requirements. The liner must be securely attached to the insert and the chimney top. The chimney must be sealed either at the top or at the damper area with a non-combustible plate to prevent room air passage to chimney cavity. Outside combustion air may be drawn through the chimney top or through an existing ash cleanout.

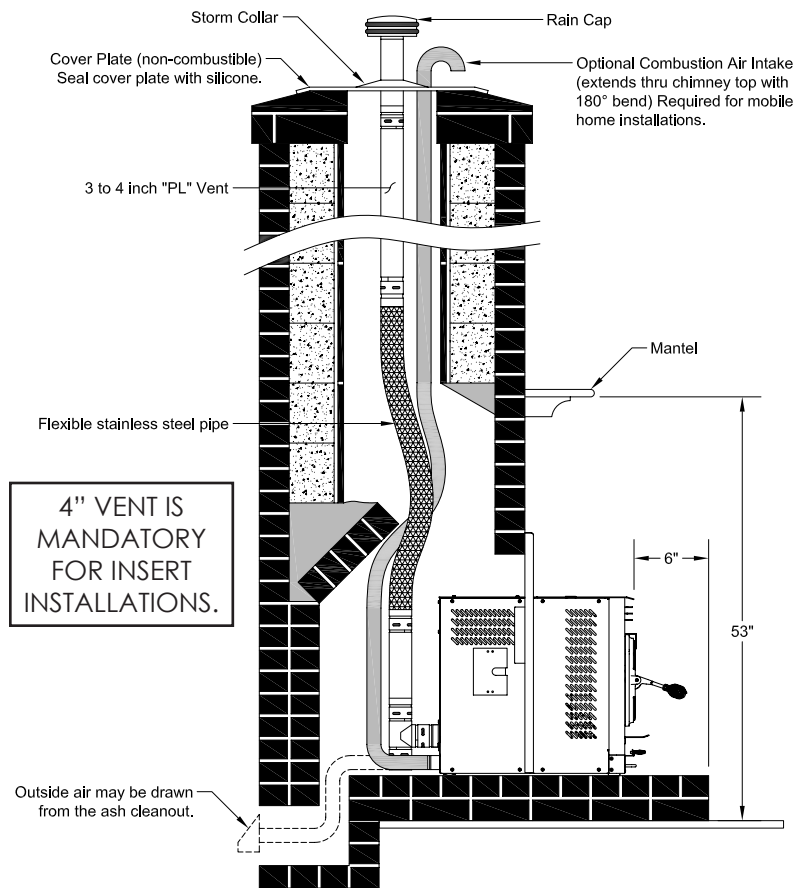

INSTALLATION INTO A FACTORY-BUILT (METAL) FIREPLACE

When installing into a zero clearance fireplace, The firebox must accept the insert without modification other than removing bolted or screwed together pieces such as smoke shelf/deflectors, ash lips, screen or door tracks, and damper assemblies. These items must be re-installed if the insert is removed and not replaced. The removal of any part must not alter the integrity of the listed fireplace in any way. The factory built fireplace must be listed per UL 127. Installation must include a chimney liner (4" Pell Vent "PL" Piping) that extends the full height of the chimney and meets type HT requirements. The liner must be securely attached to the insert and the chimney top. The chimney must be sealed either at the top or at the damper area with a non-combustible plate to prevent room air passage to chimney cavity. For raised hearth installations, adjust the leveling bolts under the front of the unit.

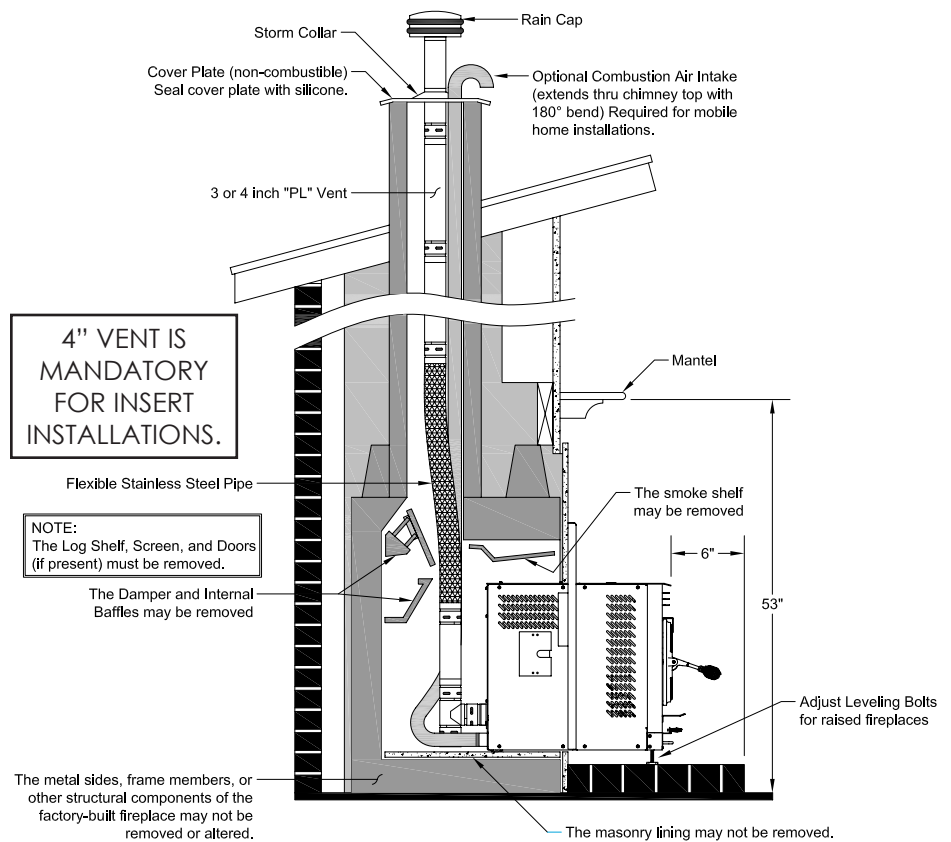

GLASS MAINTENANCE, REMOVAL AND REPLACEMENT

Your Multi-Fuel Heater comes to you with the glass door installed in place, ready for use. The glass is surrounded on the edges with a gasket and seated in a glass channel. It is held in place with two (2) clips. This unit's door uses a 1/2" diameter rope gasket.

REMOVAL OF BROKEN OR DAMAGED CERAMIC GLASS

Open the door and then lift it off of the hinges. If the door is tight, tap gently on the bottom of the door with your hand or rubber hammer. Lay door down on newspaper with glass clips facing you. Using a #2 Phillips screwdriver, loosen the screws and take off the glass clips. Remove the broken glass carefully and discard.

Reverse the above procedure for replacing new glass with new gasket. Do not over tighten the screws. Over tightening can cause the glass to break.

WARNING:

- Do not operate unit with broken glass.
- Do not substitute original factory glass.
- You must use only factory authorized glass;
- Do not slam door shut.
- Do not strike glass.
- Do not use abrasive cleaners.

CLEANING THE GLASS

When the fire is first started, it will produce some smoke. The soot might accumulate on the glass surface. Before the glass surface gets hot, open the door and wipe the glass surface off with a rag. Do not touch the surface with your hands. If after constant use, the glass is dirty, you must clean the glass so that it will not become etched with the fly ash. When the glass has cooled off, take a damp rag and clean with Hearth Glass Cleaner available from your dealer. Do not use a rag that contains nylon because it will melt to the glass.



UNDERSTANDING THE CONTROL BOARD

CONTROL PANEL

Turning the heater OFF/ON, as well as adjustments for the fuel feed rate and room fan speed are performed by pressing the appropriate button(s) on the control panel which is located on the lower left-hand side of your American Harvest heater. The insert model 60411 is located on the left facade.

This unit has two fuel operation modes for different fuels, corn or pellet. It may also be changed between an automatic operation or a manual operation in either of the fuel modes. The heater comes from the factory in the corn mode. Pressing the "ON" button on the control panel will begin the start-up sequence for the heater. The start-up sequence differs depending on which fuel operation mode you select. See Lighting Instructions for details. Pressing and holding the "ON" button will rotate the auger continuously until button is released, which feeds additional fuel.

Pressing the "OFF" button on the control panel will cause the heater to enter its shut-down sequence. The fuel feed system will stop pulling fuel from the hopper and, once the fire goes out and the heater cools down, the fans will stop running.

Pressing the "Heat Range" arrows, up or down, will adjust the amount of fuel being delivered to the burnpot.

The draft fan (exhaust) will come on as soon as the "ON" button is pressed. The fan will automatically adjust its speed in accordance to the heat range setting. However, this speed can be manually operated by pressing the "Draft Fan" arrows up or down. "Draft Fan" when pressed, the display will show "Df-A", which is automatic. Press the arrows again to adjust fan speed. When adjusting the Draft Fan setting, try only 1 setting above or below the heat setting. It is better to leave the heater in the automatic mode and adjust the manual draft slide to control the combustion air.

The room fan will come on once the unit has reached operating temperature (approx. 110°F). By pressing the "Room Fan" buttons, the display will show "Rf-A" which is automatic or "Rf-1" through "Rf-9" for manual settings. In auto mode, the room fan's speed will automatically be adjusted in accordance with the heat range setting. By pressing the "Room Fan" up arrow, you can adjust the fan speed setting up to "Rf-9". The fan speed can be adjusted to a higher setting than the heat setting but not lower than the corresponding heat range.

The "Aux" button is for Agitator operation. When the unit is "OFF" and the heater is cool, pressing the "Aux" arrows will rotate the agitator for easy removal for cleaning. The agitator, when in Automatic mode, will operate at set intervals. However, these can be changed by pressing the arrows on the "Aux" button. The agitator can be adjusted from 0 to 9, setting "0" is off and setting "9" is high.

The "Auger Delay" button can be used to pause rotation of the Auger and Agitator for approx. 1 minute. This can be cancelled by pressing the "ON" button. The "Auger Delay" is normally used only during the start up cycle to slow the fuel delivery down during the initial ignition.

The "Mode" button is used to switch between manual and automatic mode. When in auto mode, the fan, auger, and agitator will operate at preset intervals unless changed manually using the buttons mentioned above. When in manual mode, the draft fan (exhaust) will operate at full speed (100%), so the air must be controlled with the manual slide damper just below the viewing door. When the heater is in the manual mode, the optional thermostat will not properly control the unit.

During normal operation, the unit is constantly monitored for problems. In the event of an error condition, the unit will stop and an error will be displayed. See the list of error codes found at the end of this manual.

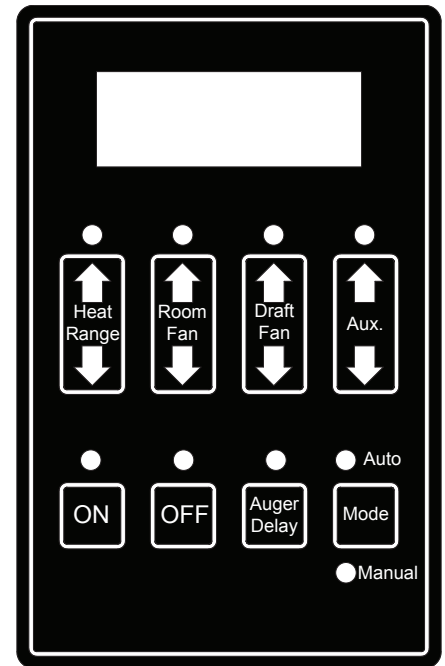

LIGHTING INSTRUCTIONS

CAUTION: DO NOT USE CHEMICALS OR FLUIDS TO START THE FIRE. HOT WHILE IN OPERATION. KEEP CHILDREN, CLOTHING AND FURNITURE AWAY. CONTACT MAY CAUSE SKIN BURNS.

Before lighting your heater for the first time, make sure that all items are out of the hopper, ash pan and firebox area. Close all doors and lids. Choose which fuel setting that you wish to operate in, Corn or Pellet. Do this by first pressing the "ON" button, then press the "Heat Range" Up and Down arrows together for approximately 3-4 seconds and release. A "C" or "P" in the first digit of the display will indicate the mode. The ON LED will be blinking and the display will show "Cr-1" or "Pr-1", depending on the mode. The "Heat Range" indicator LED and the "Auto" LED should be lit and the dash in the Heat Range display should be flashing. You will notice the draft fan starts immediately. If you press the "Heat Setting" button up, the draft fan changes speed, increasing speed the higher the heat setting. You should begin to see the igniter, located in the center and behind the burnpot, begin to glow after a short period of time. In Corn Mode, the auger and agitator will start rotating after a few minutes, allowing for proper fuel ignition. In Pellet Mode, the auger will turn immediately, then the agitator will begin to rotate once the heater reaches operating temperature. Note: The room fan will not operate at this time, as a temperature of at least 110 degrees must be reached before operating. If proper operation of your heater is confirmed, press the "OFF" button, then fill your hopper with the desired fuel. Ensure there is no foreign matter in your fuel, hopper or burnpot. You are now ready to light your Multi-Fuel Heater.

TO START A FIRE...

- **Never use gasoline, gasoline-type lantern fuel, kerosene, charcoal lighter fluid, or similar liquids to start or "freshen up" a fire in this heater. Keep all such liquids well away from the heater while it is in use. Using Wood Pellets: Ensure your display shows a "Pr" for pellets.**

This heater is designed to burn only PFI Premium grade pellets. This appliance can also burn pellets rated as standard after May 16, 2015

DO NOT BURN:

1. Garbage;
2. Lawn clippings or yard waste;
3. Materials containing rubber, including tires;
4. Materials containing plastic;
5. Waste petroleum products, paints or paint thinners, or asphalt products;
6. Materials containing asbestos;
7. Construction or demolition debris;
8. Railroad ties or pressure-treated wood;
9. Manure or animal remains;
10. Salt water driftwood or other previously salt water saturated materials;
11. Unseasoned wood; or
12. Paper products, cardboard, plywood, or particleboard. The prohibition against burning these materials does not prohibit the use of fire starters made from paper, cardboard, saw dust, wax and similar substances for the purpose of starting a fire in an affected wood heater.

Burning these materials may result in release of toxic fumes or render the heater ineffective and cause smoke.

Close all doors, lids, and cleanouts.

- Press the "ON" button and select desired heat range. This will start the ignition sequence.
- At this point, the igniter will come on and run for preset time limit (approximately 9 minutes). The auger will begin to turn and feed fuel into the burnpot. After the 9 minutes or if the heater reaches operating temperature, the igniter will shut off and normal operation will begin.
- Make fine adjustments to the air/fuel with the damper located centered, under the hearth.
- Once the heater reaches warm temperature, the room fan will start to circulate air into the room.
- If you would like to increase the life of your ignitor, you can run your heater in the "Cr" mode. However, you must place pellets in the burnpot, up to the igniter level as shown in the illustration below for auto ignition. Close the door and press the "ON" button. The igniter only runs approximately half the time in "Cr" as oppose to the "Pr" mode.

Using Corn, Soy Beans, Cherry Pits: Ensure your display shows a "Cr" for corn. NOTE: Wood pellets MUST be used for auto ignition of the fuel. Corn, Soy Beans, and Cherry Pits have a higher flash point and requires more heat to combust as opposed to wood pellets. Trying to light the heater with a fuel other than wood pellets will decrease the life expectancy of your igniter cartridge. The use of starter gel or starter pellets is not required for this heater.

- Fill the burnpot with wood pellets up to the level of the igniter port; See illustration.
- Close all doors, lids, and cleanouts.
- Press the "ON" button and select desired heat range. This will start the ignition sequence.

Once the wood fuel is ignited and the heater senses heat, the auger and agitator will begin to rotate, feeding fuel to the burnpot. NOTE: If the starting fuel is not burning hot enough, you may see the fire begin to go out as new fuel is being added. If this occurs, pressing the "Auger Delay" button will allow the auger to pause for 1 minute. Pressing the "ON" button will resume the auger if 1 min. is too long. If not enough fuel is the reason for not burning, pressing and holding the "ON" button will allow the auger to continuously deliver fuel until you release the button.

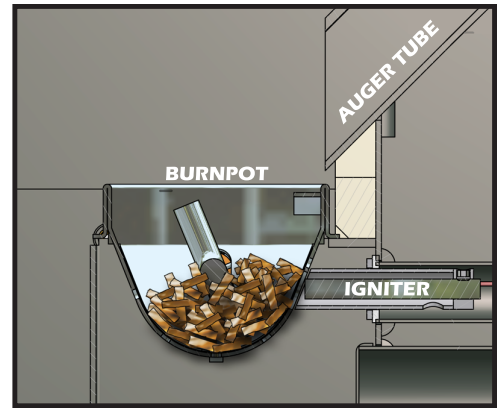

- Continue to observe the fire until most of the wood pellets have been consumed and only corn or your selected fuel is burning aggressively.
- Make fine adjustments to the air/fuel with the damper located centered, under the hearth. You should pull the damper out approximately 1 inch. It may need to be pulled out more or less depending on your selected heat setting and fuel quality. Try opening or closing by a 1/4 inch at a time.
- Once the heater reaches warm temperature, the room fan will start to circulate air into the room.
- Overfire Protection - If the heater is being overfired, burned too hot, the heater will automatically shutdown to avoid damage to components in the heater. Refer to "Lighting Instructions" for proper use.

TURNING THE HEATER OFF

Pressing the OFF button will cause the heater to enter a shutdown mode. If the heater has reached operating temperature, the OFF Indicator will blink until the shutdown procedure succeeds in lowering the heater temperature. The Room Fan will stay on to cool the heater, and the Exhaust Fan will stay on to remove smoke and heat from the combustion chamber. The Agitator will rotate continuously until shutdown is complete. The Auger will bump the fuel out every few seconds to prevent the fuel in the auger from burning. Once the temperature of the burn chamber falls below approximately 90 degrees Fahrenheit and the pressure switch detects that the door is closed, the fans will stop and the Auger will run for a few seconds to purge the auger system of any burned fuel. At this point, the OFF Indicator will go out and the heater will turn completely off. If during burning, the heater reached at least 120 degrees Fahrenheit, the shutdown procedure will include a 15 minute shutdown cycle that will keep the heater in the shutdown state for at least 15 minutes regardless of whether it is cool or pressure is detected. The 15 minute cycle can be turned off by pressing the off button during shutdown. This will cause the system to exit shutdown and return to the "OFF" mode as soon as the door is closed and the heater is cool. Continue to monitor the heater / insert after the shutdown procedure has begun. And remember, varying ambient conditions may result in a lengthy period of time for adequate cool down and the resultant shut down. Be patient, this is normal. The control board is telling the heater / insert to gradually "shut down," rather than initiate a sudden halt of fuel to the fire pot. In this way, the possibility of smoke entering the home is avoided.

NEVER shutdown or unplug the heater and leave it unattended. Observe operations for at least 20 minutes.

VISIBLE SMOKE

The amount of visible smoke being produced can be an effective method of determining how efficiently the combustion process is taking place at the given settings. Visible smoke consist of unburned fuel and moisture leaving your stove. Learn to adjust the air settings of your specific unit to produce the smallest amount of visible smoke. Wood that has not been seasoned properly and has a high wood moisture content will produce excess visible smoke and burn poorly.

MAINTENANCE INSTRUCTIONS

DISPOSAL OF ASHES

Ashes should be placed in a metal container with a tight fitting lid. The closed container of ashes should be placed on a noncombustible floor or on the ground, well away from all combustible materials, pending final disposal. If the ashes are disposed of by burial in soil or otherwise locally dispersed, they should be retained in the closed container until all cinders have been thoroughly cooled.

SMOKE AND CO MONITORS

Burning wood naturally produces smoke and carbon monoxide(CO) emissions. CO is a poisonous gas when exposed to elevated concentrations for extended periods of time. While the modern combustion systems in heaters drastically reduce the amount of CO emitted out the chimney, exposure to the gases in closed or confined areas can be dangerous. Make sure you stove gaskets and chimney joints are in good working order and sealing properly to ensure unintended exposure. It is recommended that you use both smoke and CO monitors in areas having the potential to generate CO.

SOOT AND FLYASH - FORMATION AND NEED FOR REMOVAL

The products of combustion will contain small particles of flyash. The flyash will collect in the exhaust venting system and restrict the flow of flue gases. Incomplete combustion, such as occurs during startup, shutdown, or incorrect operation of the room heater will lead to some soot formation which will collect in the exhaust venting system. The exhaust venting system should be inspected at least once per month (of heavy use) to determine if cleaning is necessary. Corn has a high ash content.

Daily Maintenance

- Surfaces on the front of the heater will be extremely hot during operation. Always wear heat resistant gloves to perform periodic maintenance.
- Using a wooden stick, tap the side heat exchangers that are located on the left and right sides of the firebox. When you open the door, they are located directly inside to the left and right. When you tap the sides with the wooden stick the loose fly ash will drop out of these holes.
- Inspect inside heater for excessive ash build up. You will learn some fuels produce more ash than others. If excessive, remove the inside ash clean-outs. Once you have cleaned out the ashes, replace the clean-outs. Depending on your fuel and use, these clean-outs may be removed only weekly.
- If clinkers develops in the firepot, clean thoroughly. You may have to do this once or twice a day depending on the moisture content of the corn. If this is not cleaned out, it could cause the agitator to jam. USSC highly recommends an additive (see Fuel Additive) be added to your corn to eliminate these clinkers. Contact your local dealer for availability and cost. You will need this additive if the agitator "fingers" develop an accumulation or build-up.
- The clinkers on the agitator and burnpot are easily removed when soaked in warm water for 10 minutes.
- The ash pan (especially the model 60411) should be cleaned out on a daily basis or as needed depending ash build-up.

SPECIAL CLEANING/OPERATIONAL INSTRUCTIONS

After cleaning or when operating the heater, you need to make sure that "both" clean-outs are in their proper position. If left out or placed incorrectly, the combustion air is effected greatly and the heater will not burn properly. Also, make sure that the ash dumps on each side of the damper are pushed in completely. This will also effect the combustion air.

WEEKLY MAINTENANCE

- Shut down the heater as directed in the operating instructions. Allow the heater to cool to room temperature. Remove the small clean-out slides in the lower corners of the firebox. Tap the sides of the burn chamber with a wooden stick. Do not tap the firewall behind the burn box as it may damage the ceramic firebrick. Scrape the fly ash from the clean-out chambers toward the front of the burn chamber. Remove the fly ash from the burn chamber and replace the clean-outs.
- Remove the ash pan and dump the ash into a metal container.

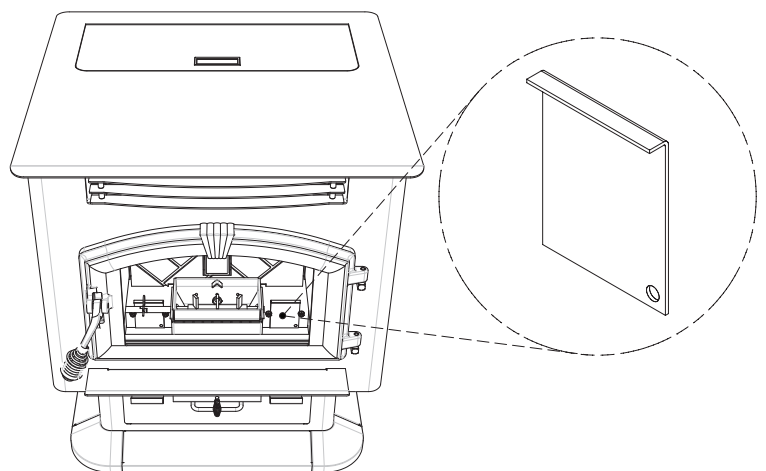

- Cleaning of the exhaust system will depend upon the ash and debris content of your fuel. If your fuel has a high ash content and/or significant debris in it, your exhaust system will require weekly cleaning. Cleaner fuels will allow for monthly cleaning of the exhaust system. Remove the exhaust pipe from the back of your heater and remove any ash that may have collected in the pipes. Replace the pipes to the heater and seal with high temperature seal tape. If you have installed proper clean out tees you will not have to take the chimney sections apart.

SPRING CLEANING

When the heating season is over make sure that you clean out all of the fuel in the hopper, firebox area, ash pan and firepot area. Corn and any ash can accumulate moisture over the summer months causing the unit to rust and the fuel to mold. Corn left in the unit will attract mice and can cause internal wiring and insulation damage. When the unit is cleaned out, take the venting apart, clean out the fly ash, rinse the venting out with a water hose and let dry, take the draft fan off and clean, clean out all areas such as back heat exchanger and lubricate the auger, auger tube, firepot area, agitator shaft and bearings and hopper area with a light oil (something like Pam cooking oil works great to coat the inside of the unit and the moving parts). Clean the glass, doors and outer cabinet so that you are ready for the next heating season. Use of a wet/dry vacuum makes all cleaning easier.

WARNING: These automatic safety features must not be bypassed

POWER OUTAGE

- During a power outage, the heater will shut down. It will not automatically restart when the power returns, unless the heater is still above the proper operating temperature and a flame still exist in the burnpot.

OVERHEATING

- A high temperature switch will automatically shut down the heater if it overheats. The heater will need to be manually relit. Allow 45 minutes before relighting. This wood heater has a manufacturer-set minimum low burn rate that must not be altered. It is against federal regulations to alter this setting or otherwise operate this wood heater in a manner inconsistent with operating instructions in this manual.
- Attempts to achieve heat output rates that exceed heater design specifications can result in permanent damage to the heater.

HOPPER SAFETY SWITCH AND PRESSURE SWITCH

- If the hopper lid is open, or if the front viewing door is not closed properly, the auger will not operate.

FUEL ADDITIVE

Chicken Scratch for my Corn Burner?

Yes - Crazy as it may sound, ground Oyster Shells, (calcium carbonate) same as fed to chickens, is the ideal additive to promote clean burning, especially when the Corn Fuel is extra high in starch. And it's available at your local Feed and Seed.

The "average" mixture is 1/2 pound of Oyster Shells (about 2 handfuls) to 60 pound of Corn, a full hopper. IF the "fingers" on your agitator (stirrer or rouser) have a noticeable buildup of "clinkers" or stubborn deposits, you have either a high starch fuel OR are burning with too much air for proper combustion and are reaching the "fusion" temperature of the Potassium and/or Starch in the Corn. You need Oyster Shells - and maybe more than a couple handfuls.

If you notice a heavy accumulation of "whitish powder" in your burn pot, reduce the amount of Oyster Shell Additive.

Remember, using this additive- as necessary - promotes efficiency (higher heat output), reduces maintenance, clinkers and ash content.

ATTENTION: This wood heater needs periodic inspection and repair for proper operation. It is against federal regulations to operate this wood heater in a manner inconsistent with operating instructions in this manual.

CONTROL BOARD FUNCTIONS

START-UP SEQUENCE OF EVENTS

Once the control panel is turned on, a timer begins that will start, stop and continue operation of the Multi-fuel Heater as a preset temperature is achieved.

COMPONENT	OPERATION START	OPERATION END
Draft Fan	Starts Immediately	Will continue until shutdown. Shutdown will occur when the operating temperature is below approx. 90 degrees.
Agitator	Begins to turn once the heater reaches operating temperature	Will continue intermediately, as determined by the "HEAT SETTING", until shutdown.
Auger	In Pellet mode: Auger turns immediately. In Corn mode: Three minutes after starting, the auger will begin to turn	The auger will continue at the feed rate specified by the "HEAT SETTING". NOTE: Safety switches, HI limit and vacuum sensor, must be activated to continue proper operation.
Room Fan	Begins to run when heater reaches operating temperature	Will continue to operate until the heater cools down to below approx. 90 degrees. This may take several hours.
Automatic Shutdown	If after 15 minutes, the heater has not reached the preset operating temperature, the unit will begin to automatically shut down.	Should the timer expire before the preset operating temperature is achieved, simply reset the heater by pressing the "ON" button.
Normal Operation	If after 15 minutes the preset operating temperature of approx. 110 degrees is achieved, normal operation will continue.	Operation will continue until either the heater's control is to the "OFF" position, or the operating temperature falls below approx. 90 degrees. At such time the heater will default to the "Automatic Shut Down".
Igniter	Starts immediately	Will continue operation for a preset time, then shut-off

SHUTDOWN SEQUENCE OF EVENTS

Once the Heater has reached the normal operating temperature and switched to the "OFF" position, the unit will initiate a slow down, reducing the fuel rate until the heater's "LOW LIMIT SAFETY" sensor tells the control board it is safe to shutdown.

COMPONENT	SHUTDOWN	OPERATION END
Draft Fan	Unchanged operation until preset "OFF" temperature is achieved.	Continues until the operating temperature falls below approx. 90 degrees. May take several hours.
Agitator	Rotates continuously until preset "OFF" temperature is achieved.	Continues until the operating temperature falls below approx. 90 degrees.
Auger	Slows down to a reduced fuel setting until preset "OFF" temperature is achieved.	The auger will continue at the reduced feed rates until the operating temperature falls below approx. 90 degrees. NOTE: Safety switches, HI limit and vacuum sensor, must be activated to continue proper operation.
Room Fan	Unchanged operation until preset "OFF" temperature is achieved.	Will continue to operate until the heater cools down to below approx. 90 degrees. This may take several hours.
Automatic Shutdown	If the heater's "HI LIMIT" sensor snaps open, this will cause an automatic shutdown. An error code will be displayed (Err1). NOTE: "HI LIMIT" errors are usually the result of operating at the highest heat setting for long periods of time, room fan failure or loose wire connection.	It is rare that the HI LIMIT temperature is reached. However, should this error occur, let the heater cool down for an hour then restart.

CAUTION: When performing any internal electrical maintenance

- Moving parts inside of the cabinet may cause injury. Do not operate unit with panels removed or open.
- HOT parts. Do not operate the unit with panel open.
- Risk of electric shock. Disconnect power before servicing unit.
- In the event of component failure, replace with the original factory equipment.

ERROR CODES and DISPLAY INDICATORS

Error Code	Error Description	Possible Causes
Err1	The high limit temperature sensor has tripped.	Inadequate ventilation. Room fan failure. Exhaust Blockage. Electrical Open in the over temperature switch or wiring.
Err2	The low limit temperature sensor has tripped.	Hopper Empty. Auger output failure or jam. Poor flame or fuel quality caused fire to burn too slowly or go out. Electrical Open in low temperature switch or wiring. Fire was not well established before the PCB's programmed time limit expired.
Err3	The heater was unable to reach the Room Fan On temperature within the startup time.	Poor flame or fuel quality caused fire to burn too slowly or go out. Auger output failure or jam Hopper empty on startup.
Err4	The power failed while the heater was hot, and when power was restored, the fire was out.	Electrical Open in low temperature switch or wiring. Power loss
Err5	The Auger output fuse has blown.	Auger motor jammed or bad.
Err6	The Agitator output fuse has blown.	Agitator motor jammed or bad.
Err7	The Draft Fan (Exhaust Fan) output fuse has blown.	Draft Fan motor jammed or bad.
Err8	The Room Fan output fuse has blown.	Room fan motor jammed or bad.
Err9	Zero Crossing Input failed	AC supply frequency out of range.
Err10	The Igniter output fuse has blown	Igniter output has shorted/blown or igniter overload.

DISPLAY INDICATORS

Several situations or events are indicated in normal operation by blinking display indicators or segments in the display:

Flashing On Indicator: This means that the heater is in the "Start Up" awaiting for the ignition procedure to complete.

Flashing Off Indicator: This indicates that the heater is in the "Shutdown" state waiting for the OFF button, or for a 15 minute period after the heater was turned off, or for the heater to cool down, or for the door to be closed.

Flashing dash in Heat Range Display: This indicates that the heater is in the normal run mode and is ramping from the current heat range setting to the target heat range setting. Once the ramp is complete, the dash will stop flashing. For ramping from heat range 1 to 5, the default time is 12 minutes (with a 90 second ramp time).

Flashing heat range value in "Heat Range" display: For example, if the display is showing "Hr-3" and the '3' is blinking, this indicates that the heater thermostat input is open and not calling for heat. While this is happening, the actual heat range value is 1 (low).

Flashing Automatic Mode Indicator: This indicates that the heater is in normal operation and is running in the automatic mode. However, either the Draft Fan or Auxiliary setting is manually configured.

Flashing Draft Fan Setting Indicator: This indicates that the heater is in normal operation and that the vacuum sensor detects a loss of pressure either because the door is open or because there is a negative pressure in the room with respect to the exhaust.

Flashing Aux Indicator: This indicates that the igniter is on during the lighting stage.

Quick (changes twice per second) Flashing Heat Range Setting Indicator: This indicates that the heater is in normal operation and that an over temperature condition exists causing the fuel to stop.

Slow (changes once per second) Flashing Heat Range Setting Indicator: This indicates that the heater is in a cutback condition in an attempt to prevent an over temperature shutdown.

FACTORY DEFAULTS

To return the control to its original factory default settings, press and hold the AUX UP and AUX DOWN buttons together for three seconds.

TROUBLE SHOOTING

- Disconnect the power supply before performing any maintenance! NOTE: Turning the heater to "OFF" does not disconnect the power to all of the electrical components of the heater.
- Never try to repair or replace any part of the heater unless instructions for doing so are given in this manual. All other work should be done by a trained technician.

PROBLEM	CAUSE: Too rich air/fuel mixture
Orange, lazy flame, excessive fuel build-up in the burnpot.	Clean out the burnpot Make sure the cleanouts on each side of the damper are closed completely. Not enough combustion air. Adjust the air damper to a more open position. Make sure that the viewing door is closed and sealed properly. If not, adjust the door catch or replace the gasket. Check that all outside connections are clear of any obstructions. Check the exhaust system, clean as needed.
PROBLEM	Cause: Burnpot out of fuel
Fire goes out or heater shuts down	Hopper is empty, refill the hopper Loss of draft pressure. Make sure the viewing door is closed and sealed properly. Check the outside connections for any obstructions. Check the exhaust system; clean as needed. Check that the pressure switch connection to the firebox is free of ashes or clear of any obstructions. Auger system may be jammed or there is a "bridging" of fuel in the hopper preventing fuel flow into the auger feed system. Too much combustion air. Adjust damper to a more closed position.
PROBLEM	Cause: Auto-Start Igniter fails to ignite the fuel in the burnpot.
Heater does not start a fire when the "ON" button is pressed.	Check the pellets quality. If moist or damp, replace with dryer fuel. Check that the auto-start igniter port is not blocked with ash or soot. (The igniter is located behind the burnpot.) The auto-start igniter should glow on start-up. If you can not visible see the igniter glowing, then it may need to be replaced or there is a problem with the electrical system. Check wiring. Loss of draft pressure. Make sure the viewing door is closed and sealed properly. Check the outside connections for any obstructions. Check the exhaust system; clean as needed.
PROBLEM	Cause: Not enough combustion air or fuel has too much moisture.
Viewing glass becomes black shortly after start-up.	Adjust the air damper to a more open position. Use a fuel with less moisture content.
PROBLEM	Cause: Not enough combustion air or fuel has too much moisture.
"Black Popcorn" is present in the burn chamber.	Not enough combustion air. Adjust the air damper to a more open position. Check moisture content in corn. Use corn with a moisture content of 11-12% or less.
PROBLEM	Cause: Corn is wet or has a high moisture content.
Corn builds up in burnpot or is not burning completely. Steam is coming from corn.	Not enough combustion air. Adjust the air damper to a more open position. Check moisture content in corn. Use corn with a moisture content of 11-12% or less.
PROBLEM	Cause: Chemical reaction between the starches in corn and the heat.
"Clinkers" form in burnpot and on agitator.	Adjust air mixture. Add calcium carbonate (aka chicken scratch or oyster shell) Try running a mixture of wood pellets and corn.

WIRING DIAGRAM

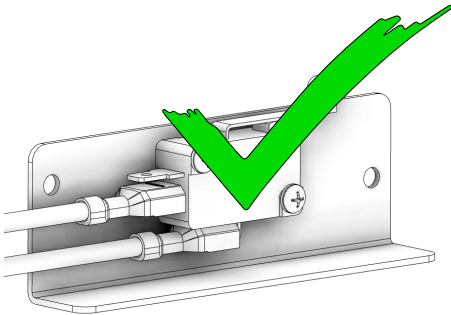
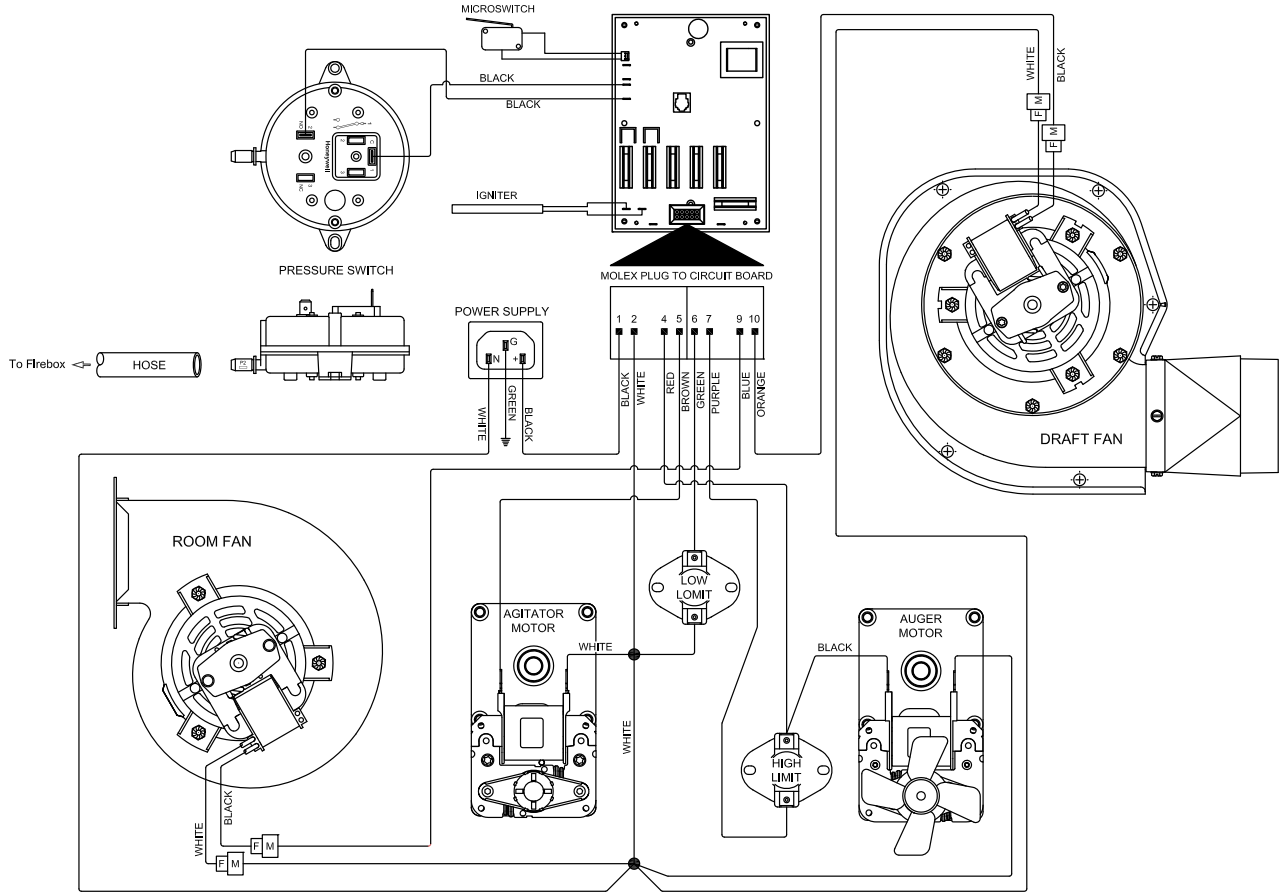

CORRECT

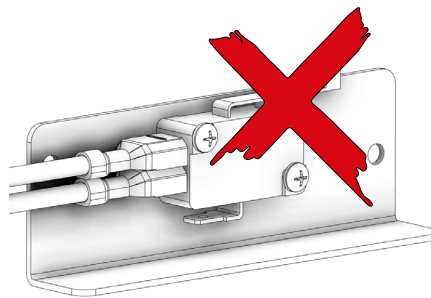

WRONG

Ensure the wires are connected to the bottom two prongs of the hopper switch as shown.

WIRING SCHEMATIC

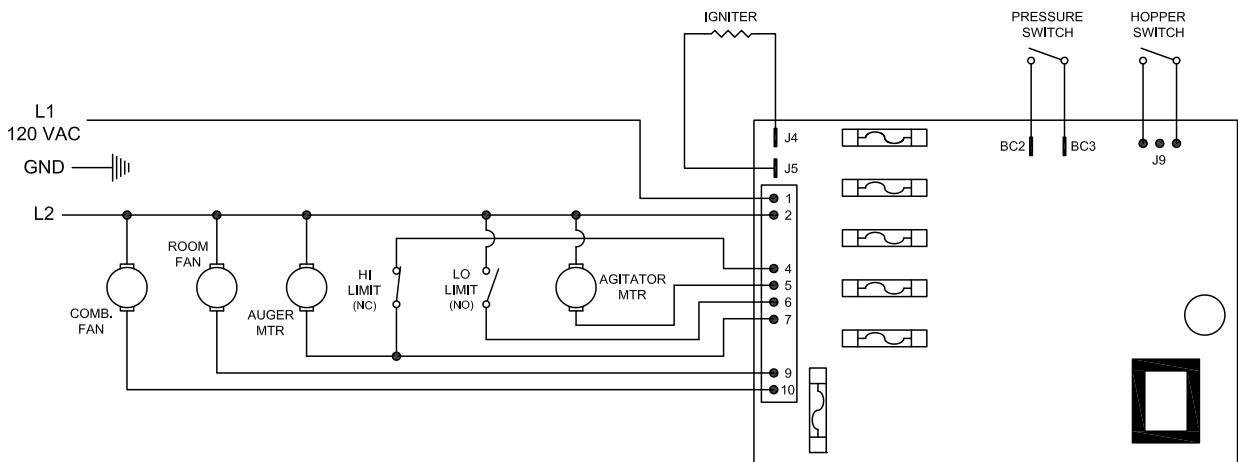

PARTS DIAGRAM

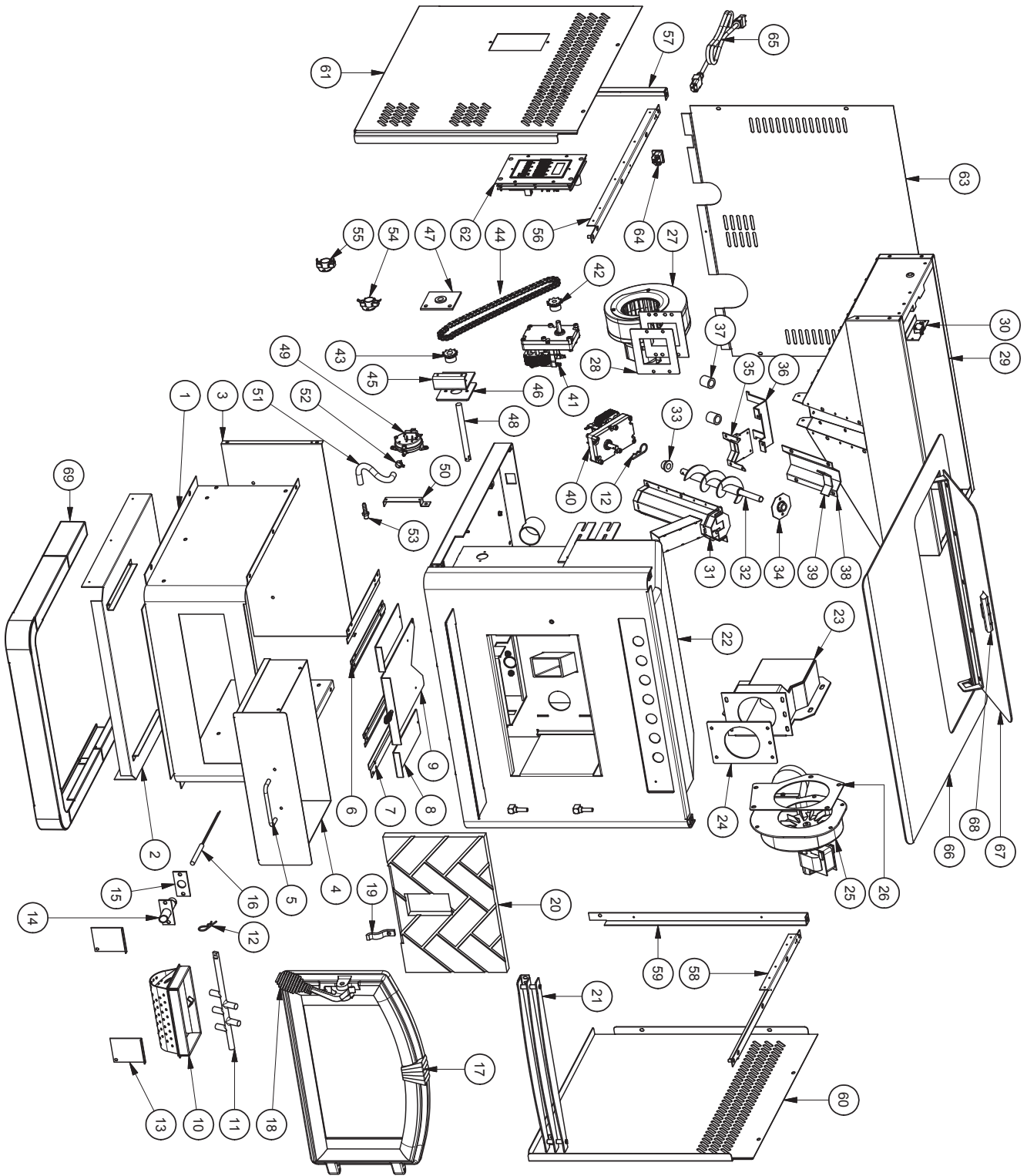

PARTS LIST

Key	Part No.	Description	Qty.
1	69529	Pedestal	1
2	25410	Pedestal Bottom	1
3	25451	Pedestal Back	1
4	69478	Ash Pan	1
5	891137	Handle	1
6	25533	Damper/Cleanout Guide	2
7	25532	Cleanout Guide	2
8	25531	Ash Cleanout (Lower)	2
9	69528	Damper	1
10	891660	Burnpot	1
11	891059	Agitator	1
12	83529	Hair Pin	2
13	25524	Ash Cleanout (Inner)	2
14	69593	Igniter Tube Weldment	1
15	88118	Igniter Flange Gasket	1
16	80543	Igniter Cartridge	1
17	69516	Feed Door Assembly	1
18	891135	Spring Handle (Large)	1
19	25080	Door Latch	1
20	891705	Vermaculite Board (Herringbone)	1
21	69497	Louver Assembly	1
22	88116	Insulation (Kaowool)	1
23	86627	Exhaust Duct	1
24	88114	Exhaust Duct Weldment	1
25	80473	Exhaust Blower	1
26	88100	Exhaust Blower Gasket	1
27	80472	Distribution Blower	1
28	88106	Distribution Blower Gasket	1
29	69598	Hopper Assembly - Complete	1
30	80491	Micro Switch	1
31	891164	Auger Housing Weldment	1
32	891141	Auger	1
33	891132	Bottom Bushing (Retaining Ring - Pt #: 83534)	1
34	69514	Top Bushing Plate Assy.	1
35	891248	Bottom Plate Retainer	1

36	891195	Drive Motor Bracket	1
37	891169	Hose (2 per)	0.167 ft
38	891180	Auger Cover	
39	88120	Gasket, 0.188 x 1.0 Flat FbrGlss.	0.25 ft
40	80488	Drive Motor (Auger)	1
41	80456	Drive Motor (Agitator)	1
42	891083	Sprocket, Motor	1
43	891057	Sprocket, Shaft	1
44	891058	Chain - 36 Links	1
45	69594	Primary Bushing Assembly	1
46	88111	Agitator Bracket Gasket	1
47	69595	Secondary Bushing Assembly	1
48	891706	Drive Shaft - Agitator	1
49	80549	Pressure Switch	1
50	25648	Pressure Switch Bracket	1
51	891121	Silicone Hose	0.4 ft
52	83564	Hose Clamp	1
53	89586	Auger Nipple	1
54	80381	110°F Snap Disc (Low Limit)	1
55	80390	170°F Snap Disc (High Limit)	1
56	69506	Cabinet Support, Top/Left	1
57	25448	Support Frame, Back/Left	1
58	69505	Cabinet Support, Top/Right	1
59	25447	Support Frame, Back/Right	1
60	25412	Right Cabinet Side	1
61	25411	Left Cabinet Side	1
62	80575	PCB, Circuit Board	1
N/S	80485	Wiring Harness, Main	1
63	25682	Cabinet Back	1
64	80462	Receptacle, 3-Prong	1
65	80461	Power Supply Cord	1
66	69586MB	Top/Lid Assembly	1
67			
68	891148	Plastic Handle	1
69	891963	Pedestal Trim (One Piece)	1
N/S = Not Shown			

In order to maintain warranty, components must be replaced using original manufacturers parts purchased through your dealer or directly from the appliance manufacturer. Use of third party components will void the warranty.

PARTS DIAGRAM

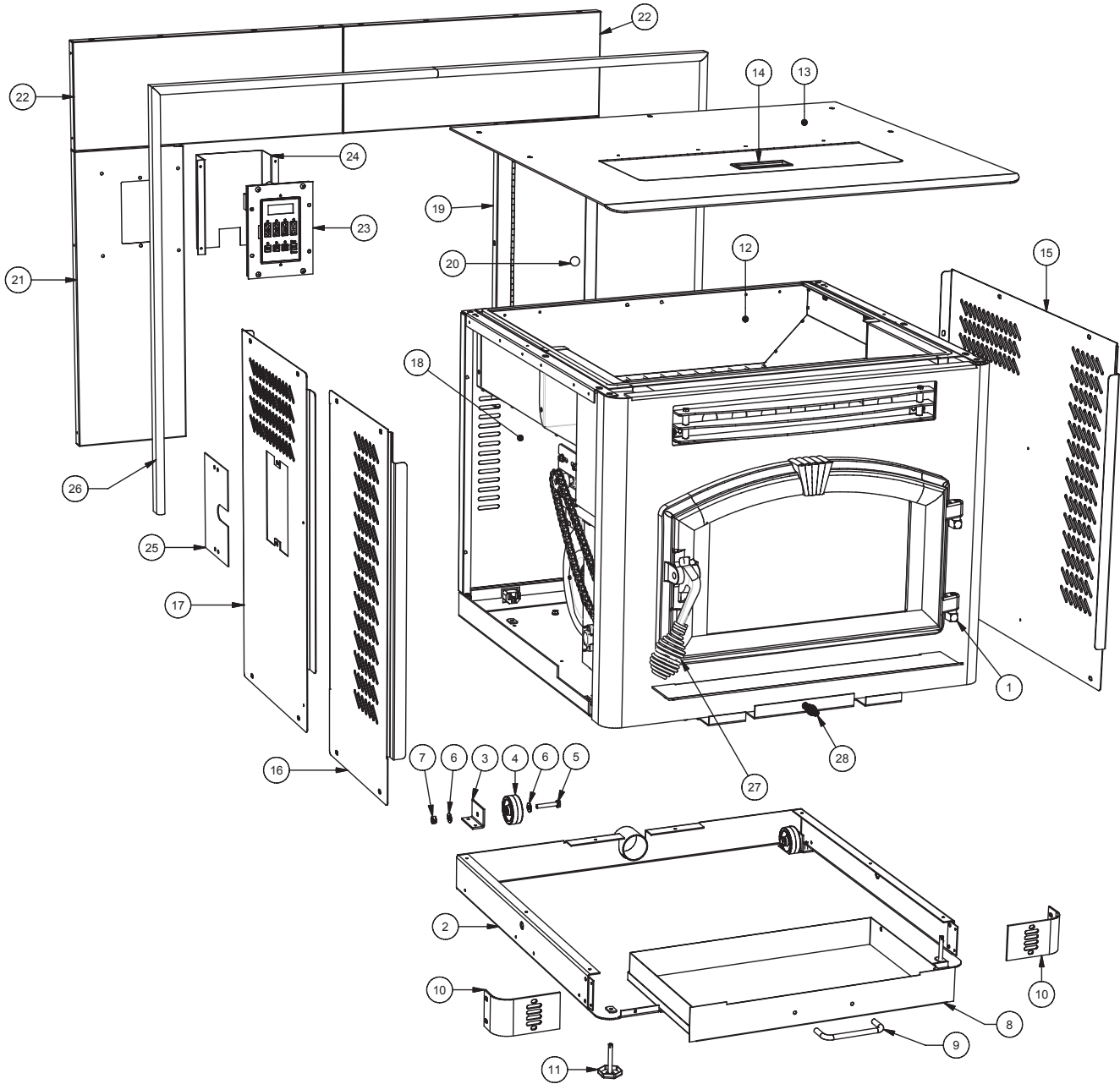

PARTS LIST

Notice:

For all other repair components not listed above, refer to the 6041TP Repair list and diagrams for info.

Key	Part No.	Description	Qty.
1	891373	Pad, Door Hinge (Threaded)	2
2	69547	Weldment Sub-Base	1
3	25569	Bracket, Caster	2
4	891424	Caster, Plastic	2
5	83412	1/4-20 x 1-1/2 Hex Bolt	2
6	83136	Washer	4
7	83261	1/4-20 Lock Nut	2
8	69548	Weldment, Ash Pan	1
9	891137	Handle (Brushed Nickel)	1
10	25570	Facade, Bottom	2
11	83479	Leveler	2
12	69619	Hopper Assembly	1
13	69765	Weldment, Cabinet Top	1
14	891148	Handle, Plastic	1
15	25581	Right Side Cabinet	1
16	25579	Left Side-Front Cabinet	1
17	25580	Left Side-Rear Cabinet	1
18	25578	Back, Cabinet	1
19	69766	Wldmt., Facade Panel Rt-Side	1
20	89943	Knob, Cabinet Door	1
21	25585	Panel-Left Side Facade	1
22	25590	Top-Panel, Facade (2 piece)	2
23	80575	Circuit Board (PCB)	1
24	25583	Cover, PCB	1
25	25582	Cover, Panel	1
26	891435	Kit, Facade Trim (B-Lux)	1
27	891135	Handle, Spring (Large)	1
28	891331	Handle, Spring (Small)	1

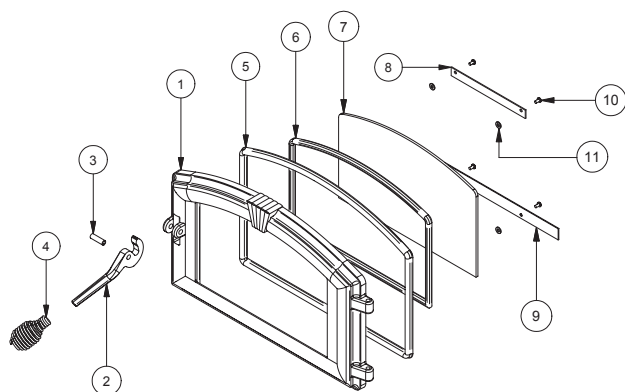

Key	Part No.	Description	Qty
1	25491	Feed Door	1
2	25492	Handle, Door	1
3	83506	Roll Pin, 3/8 x 1-1/4	1
4	891135	Handle, Spring (Parts Bag)	1
5	88112	Gasket, 1/2" Sq. Rope	5 ft
6	88087	Gasket, Glass (1 x 3/16)	4 ft
7	891131	Glass Ceramic	1
8	25464	Retainer, Top Glass	1
9	25465	Retainer, Bottom Glass	1
10	83202	Machine Screw	4
11	83278	#10 Flat Washer	4

Add the suffix "MB" to the part number of any painted part.

In order to maintain warranty, components must be replaced using original manufacturers parts purchased through your dealer or directly from the appliance manufacturer. Use of third party components will void the warranty.

HOW TO ORDER REPAIR PARTS

This manual will help you obtain efficient, dependable service from your heater, and enable you to order repair parts correctly.

Keep this manual in a safe place for future reference.

When writing, always give the full model number which is on the nameplate attached to the heater.

When ordering repair parts, always give the following information as shown in this list:

1. The part number _____
2. The part description _____
3. The model number _____
4. The serial number _____

United States Stove Company
227 Industrial Park Road
P.O. Box 151
South Pittsburg, TN 37380
(800) 750-2723
WWW.USSTOVE.COM