

Owner's Instruction and Operation Manual

**UNITED STATES
STOVE CO.**

EST[®] 1869



Model Number:

1500

COAL ONLY



Report Number: F21-692

CERTIFIED TO UL 391-2006 (R2019)

DO NOT USE THIS FURNACE IN A MOBILE HOME OR TRAILER.

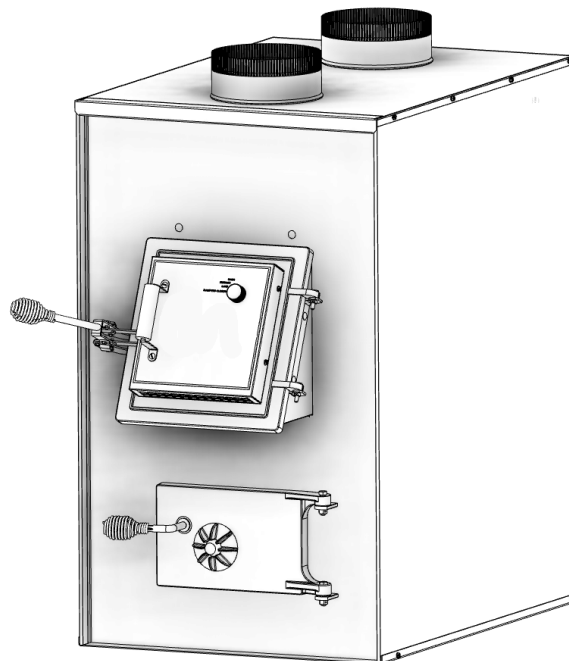

* All Pictures In This Manual Are For Illustrative Purposes Only. Actual Product May Vary.

851486S - 1903N

Save These Instructions In A Safe Place For Future Reference.



SAFETY NOTICE: If this heater is not properly installed, a house fire may result. For your safety, follow the installation instructions. Never use make-shift compromises during the installation of this heater. Contact local building or fire officials about permits, restrictions and installation requirements in your area. **NEVER OPERATE THIS PRODUCT WHILE UNATTENDED.**



CAUTION! Please read this entire manual before you install or use your new room heater. Failure to follow instructions may result in property damage, bodily injury, or even death. Improper Installation Will Void Your Warranty!

U.S. Environmental Protection Agency

This heater is not certified for wood burning. Use of any wood fuel is a violation of federal regulations.



CALIFORNIA PROPOSITION 65 WARNING:

This product can expose you to chemicals including carbon monoxide, which is known to the State of California to cause cancer, birth defects, and/or other reproductive harm. For more information, go to www.P65warnings.ca.gov

THIS MANUAL IS SUBJECT TO CHANGE WITHOUT NOTICE.

FOR PARALLEL INSTALLATION WITH EXISTING FORCED AIR-GAS OR OIL FIRED FURNACE (U.S. ONLY) FOR INSTALLATION AS A CENTRAL FURNACE.

NOTE: YOUR UNIT MUST BE INSTALLED BY A QUALIFIED FURNACE INSTALLER.

DIMENSIONS

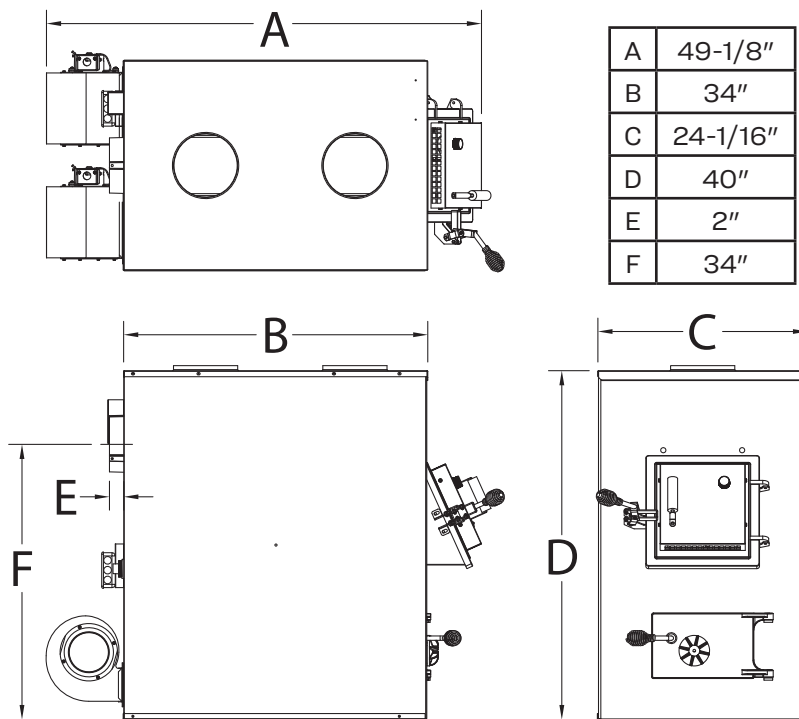

CAUTIONS:

- **HOT WHILE IN OPERATION. KEEP CHILDREN, CLOTHING AND FURNITURE AWAY. CONTACT MAY CAUSE SKIN BURNS.**
- **DO NOT USE CHEMICALS OR FLUIDS TO IGNITE THE FIRE.**
- **DO NOT LEAVE THE STOVE UNATTENDED WHEN THE DOOR IS SLIGHTLY OPENED.**
- **DO NOT BURN GARBAGE, FLAMMABLE FLUID SUCH AS GASOLINE, NAPHTHA OR MOTOR OIL.**
- **DO NOT CONNECT TO ANY AIR DISTRIBUTION DUCT OR SYSTEM.**
- **ALWAYS CLOSE THE DOOR AFTER THE IGNITION.**
- **YOUR CHIMNEY MUST BE INSPECTED PRIOR TO THE INSTALLATION OF YOUR NEW COAL STOVE. IN ADDITION, YOU SHOULD HAVE YOUR CHIMNEY INSPECTED FOR CREOSOTE DEPOSTS MONTHLY DURING THE HEATING SEASON AND ANNUALLY INSPECTED AND CLEANED.**



Note: Register your product by using your smart phone with the QR code. Save your receipts with your records for any warranty claims.

You can also register your product online at www.usstove.com/support/product-registration / OR by downloading the US Stove Company app available for iOS and Android.

For Customer Service, please call:

1-800-750-2723 Ext 5050 or;

Text to 423-301-5624 or;

Email us at:

customerservice@usstove.com

INSTALLATION CHECKLIST



Your coal stove should be installed by a qualified installer only. An NFI qualified Installer can be found at www.nficertified.org/public/find-an-nfi-pro/

CUSTOMER SERVICE

1-800-750-2723 ext 5050

Text to 423-301-5624

Email to: Customerservice@usstove.com

COMMISSIONING CHECKLIST

This Checklist is to be completed in full by the qualified person who installs this unit. Keep this page for future reference. Failure to install and commission according to the manufacturer's instructions and complete this checklist will invalidate the warranty.

Please Print

Customer Name:	Telephone Number:
Address:	
Model:	
Serial Number:	
Installation Company Name:	Phone Number:
Installation Technician's Name:	License Number:

DESCRIPTION OF WORK

Location of installed appliance: _____

Venting System: New Venting System Yes No If yes, Brand _____

If no, Date of inspection of existing venting system: _____

COMMISSIONING

- Confirm Hearth Pad Installation as per Installation Instructions.....
- Confirm proper placement of internal parts.....
- Check soundness of door gasket and door seals
- Confirm clearances to combustibles as per installation instructions in this manual
- Check the operations of the air controls.....
- Confirm the venting system is secure and sealed
- Confirm the stove starts and operates properly
- Check to ensure a CO alarm is installed as per local building codes and is functional
- Explain the safe operation, proper fuel usage, cleaning, and routine maintenance requirements.....

Declaration of Completion: As the qualified person responsible for the work described above, I confirm that the appliance as associated work has been installed as per manufacturer's instructions and following any applicable building and installation codes.

Signed: _____ Print Name: _____ Date: _____

Home Owner: RETAIN THIS INFORMATION FOR FUTURE REFERENCE

ATTENTION:

- **FAILURE TO FOLLOW THE INFORMATION IN THIS MANUAL WILL CAUSE A HAZARD THAT COULD RESULT IN DEATH, SERIOUS BODILY INJURY, AND/OR PROPERTY DAMAGE.**
- **CHECK YOUR LOCAL CODES. THE INSTALLATION MUST COMPLY WITH THEIR RULINGS.**
- **ALWAYS CONNECT THIS FURNACE TO A CHIMNEY AND VENT TO THE OUTSIDE. NEVER VENT TO ANOTHER ROOM OR INSIDE A BUILDING.**
- **DO NOT CONNECT THIS FURNACE TO AN ALUMINUM TYPE B GAS VENT. THIS IS NOT SAFE AND IS PROHIBITED BY THE NATIONAL FIRE PROTECTION ASSOCIATION CODE. THIS FURNACE REQUIRES A MASONRY OR LISTED FACTORY BUILT CHIMNEY FOR RESIDENTIAL TYPE OR BUILDING HEATING APPLIANCE CHIMNEY. USE A 6" DIAMETER CHIMNEY OR LARGER, THAT IS HIGH ENOUGH TO GIVE A GOOD DRAFT.**
- **INSPECT CHIMNEY CONNECTOR AND CHIMNEY BEFORE AND FREQUENTLY DURING THE HEATING SEASON FOR ANY DEPOSIT OF CREOSOTE OR SOOT WHICH MUST BE REMOVED.**
- **PROVIDE AIR FOR COMBUSTION INTO THE ROOM WHERE THE FURNACE IS LOCATED. IF THE INTAKE IS NOT IN THE SAME ROOM, AIR MUST HAVE FREE ACCESS TO THE ROOM.**
- **CAST IRON PARTS MUST BE "SEASONED" TO AVOID CRACKING, BUILD ONLY SMALL FIRES ON FIRST USE.**
- **TO PREVENT INJURY, DO NOT ALLOW ANYONE TO USE THIS FURNACE WHO IS UNFAMILIAR WITH THE CORRECT OPERATION OF THE FURNACE.**

CAUTION

GASES THAT ARE DRIVEN FROM FRESH COAL MUST BE BURNED OR THEY WILL ACCUMULATE AND EXPLODE. NEVER SMOTHER A FIRE WHEN ADDING FRESH COAL.

DANGER: RISK OF FIRE OR EXPLOSION.

DO NOT BURN GARBAGE, GASOLINE, DRAIN OIL, OR OTHER FLAMMABLE LIQUIDS.

WARNING: FIRE HAZARD.

- **DO NOT OPERATE WITH FIRE DRAFT EXCEEDING 0.06" W.C.**
- **DO NOT STORE FUELS, PAINTS, THINNERS, FLAMMABLE LIQUIDS, OR OTHER HIGHLY VOLATILE SUBSTANCES IN THE FURNACE ROOM.**

CAUTION!

CLEANOUT OF THE HEAT EXCHANGER, FLUE PIPE, CHIMNEY, AND DRAFT INDUCER (IF USED), IS ESPECIALLY IMPORTANT AT THE END OF THE HEATING SEASON TO MINIMIZE CORROSION DURING THE SUMMER MONTHS, CAUSED BY ACCUMULATED ASH.

CAUTION!

INSPECT FLUE PIPES, FLUE PIPE JOINTS AND FLUE PIPE SEALS REGULARLY TO ENSURE THAT SMOKE AND FLUE GASES ARE NOT DRAWN INTO, AND CIRCULATED BY, THE AIR CIRCULATION SYSTEM.

SAFETY NOTICE:

IF THIS HEATER IS NOT PROPERLY INSTALLED, A HOUSE FIRE MAY RESULT. FOR YOUR SAFETY, FOLLOW THE INSTALLATION DIRECTIONS. CONTACT LOCAL BUILDING OR FIRE OFFICIALS ABOUT RESTRICTIONS AND INSTALLATION INSPECTION REQUIREMENTS IN YOUR AREA. IF NOT ALREADY INSTALLED, WE RECOMMEND THAT SMOKE DETECTORS BE INSTALLED.

CAUTION:

HOT SURFACES! KEEP CHILDREN AWAY. DO NOT TOUCH DURING OPERATION.

CREOSOTE ACCUMULATION CAUSES CHIMNEY FIRES. YOU SHOULD CHECK (OR HAVE CHECKED BY A QUALIFIED CHIMNEY SWEEP) YOUR CHIMNEY FOR CREOSOTE DEPOSITS AT LEAST MONTHLY DURING THE HEATING SEASON. ANY ACCUMULATIONS SHOULD BE REMOVED. COMPLETE CHIMNEY INSPECTIONS AND CLEANING SHOULD BE CONDUCTED ANNUALLY; TYPICALLY, THIS TASK SHOULD BE PERFORMED PRIOR TO EACH HEATING SEASON. IF USING AN EXISTING CHIMNEY, IT MUST BE INSPECTED PRIOR TO THE INSTALLATION OF YOUR NEW WOOD STOVE.

ASSEMBLY & INSTALLATION

Your furnace requires the following items to be assembled or installed by the service person:

- Feed Door Pull Handle
- Feed Door Locking Handle
- Blowers and Blower Controls
- Electrical Connections

1. Remove all parts from inside the furnace and inspect for damage, including the firebrick as some breakage could occur during shipment.
2. Assemble the feed door pull handle as shown. Install thermostat assembly and cover (complete with handle) as illustrated.

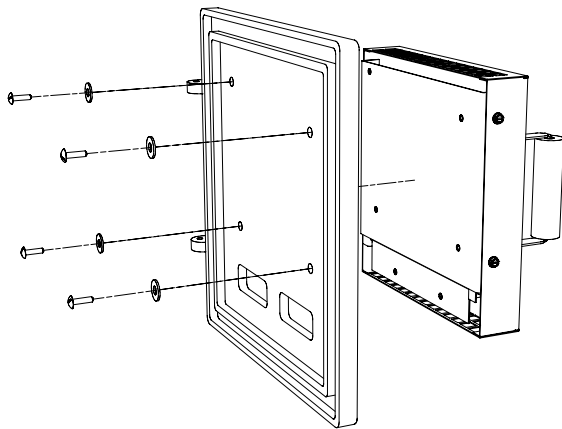

3. Align thermostat control knob with flat on thermostat control shaft and press onto shaft.

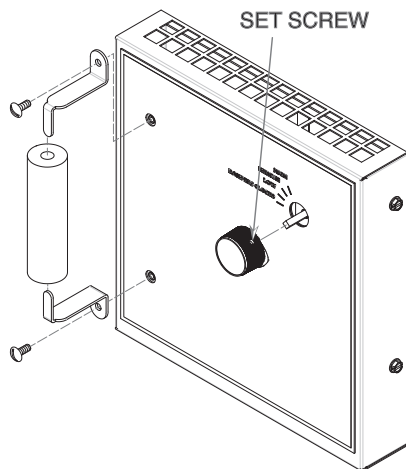

4. Attach feed door locking handle with screws and nuts provided. Note: Slotted holes are for adjustment of handle. Adjust handle until some pressure is required to lock feed door during firing sequence.

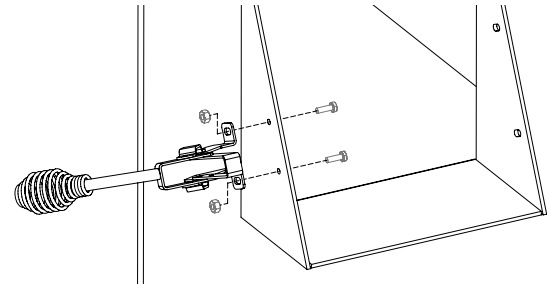

5. Install the thermodisc on rear of furnace cabinet with the two screws provided. Mount the conduit assembly from the junction box to the thermostat bracket. Crimp the two female terminals to each of the wire leads. Plug the wires to the thermodisc. NOTE: It does not matter which of the two wires plugs to which terminal on the thermodisc.
6. Remove blowers from cartons. Remove junction box cover. Attach clip nuts as shown. Install blowers and gaskets with 1/4"-20 x 3/4" bolts as shown.

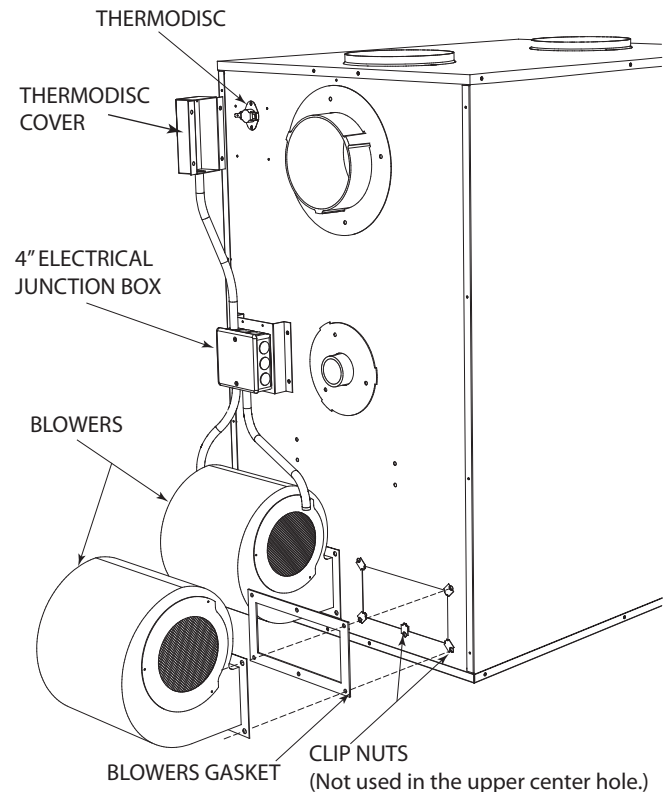

7. Wire right side blower first (See wiring diagram) and replace cover on junction box on blower.
8. Wire left blower same as above and replace cover.
9. Check operation of shaker grates with grate handle before operating furnace.

11DIKL DRAFT INDUCER KIT W/ LIMIT SWITCH

This optional kit allows your furnace to be thermostatically controlled and gives the option to change the on/off times of the distribution blower(s).

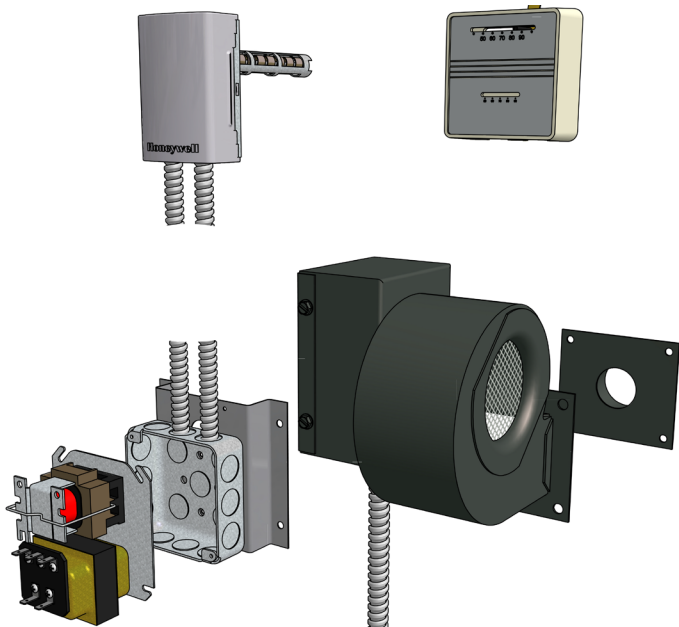

DR-6 BAROMETRIC DAMPER REGULATOR

In the unlikely event that your furnace “overfires” (a condition evidenced by elbows, stove pipes, and connectors glowing red in appearance or otherwise discoloring), then your installation is subject to excessive draft created by either a chimney too tall or too great in diameter in conjunction with its height, or some other factor of an indeterminate cause. In this event, you should install a barometric draft regulator. Such installation will preclude any over-firing and/or any hazardous consequences of potential overfiring. Barometric draft regulators are generally available where you purchased your stove or may be ordered directly from United States Stove Company at a nominal charge.

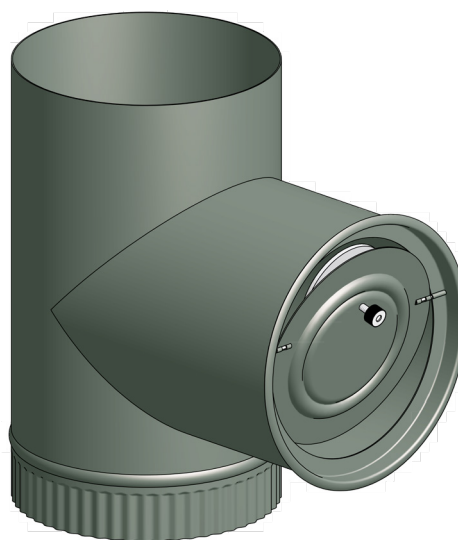

UFB908 UNIVERSAL FILTER BOX

When installing ANY warm air furnace, proper installation is the key and required for getting the most efficiency and longest life out of your unit. Failure to install your furnace as outlined from the manufacturer, often will result in inadequate heating and problems associated with drafting. U. S. Stove Co. offers the UFB908, a universal filter box that mounts to the rear of the unit that your return air duct work will attach to. It uses a standard 16 x 20 x 1 filter (NOT INCLUDED) to reduce the amount of dust particles from being transferred thru you duct work system.

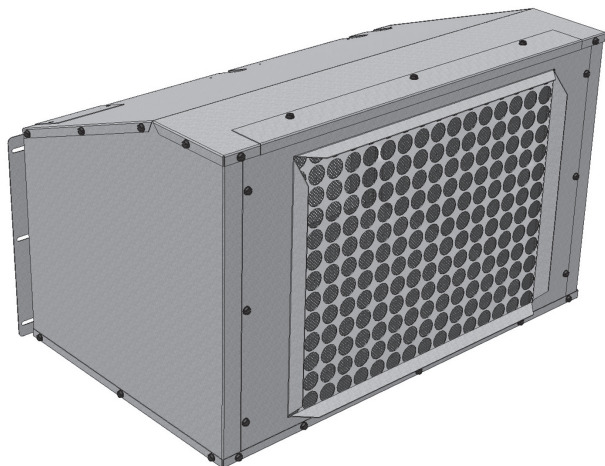

Your Furnace is designed to be installed in a parallel air flow arrangement with a gas or oil-fired forced air upflow-type central furnace, or it may be installed as a central furnace.

HOW THE FURNACE FUNCTIONS

This furnace is designed to be a supplemental or central heating source for your home. This solid fuel furnace may be installed in conjunction with a properly operating central furnace that is listed or certified in accordance with nationally recognized safety standards and equipped with the required controls and other safety features and which has been installed in accordance with appropriate standards of the National Fire Protection Association with installation clearances specified in the furnace nameplate marking. The installation must be accomplished by a qualified agency (one who is engaged in, and is responsible for, or is thoroughly familiar with the installation and operation of the gas, oil, and solid fuel burning heating appliances, who is experienced in such work, familiar with all the requirements of the authority having jurisdiction.) The installation shall be in strict accordance with the manufacturer's installation instructions furnished with the solid fuel furnace. The chimney connector of the furnace is to be installed to provide clearances to combustible material not less than specified in the individual classifications and marked on the furnace. The chimney connector must be connected to a chimney suitable for use with residential type or building heating appliances which burn solid fuel. The Furnace is designed to operate in either parallel or series air flow arrangement with the central furnace or as a central furnace.

CENTRAL FURNACE INSTALLATION

As a central furnace, the unit functions independently of any other system. The blower will come on when the plenum temperature reaches the setting on the blower control.

PARALLEL INSTALLATION (U.S. ONLY)

The design is such that when the blower comes on, the blower on the central system also comes on. The blower will only come on when the temperature in the plenum has reached the setting on the blower control. This is to ensure that there is sufficient warm air in the system to make it efficient for the unit to operate. When the central

system thermostat calls for heat, the central system will operate by the burner igniting and the blower coming on. It is possible that both systems will operate simultaneously. It is recommended that for the most efficient use of this furnace, that it be fired as much as possible in order to reduce the demand on your existing central heating system. This unit has an optional forced draft kit that operates from a wall thermostat. When the temperature falls below the setting on the wall thermostat, the forced draft will come on (U.S. Stove Option 11/DIKL) The warm air supply outlet of the this furnace shall not be connected to the cold air return of the central furnace, because the possibility exists of components of the central furnace overheating and causing the central furnace to operate other than is intended.

SERIES INSTALLATION

This type of installation uses only the blowers of the existing central furnace. The solid fuel fan/limit control must also control the functions of the existing furnace. All electrical power must come from a single branch circuit.

LOCATING THE FURNACE

1. The furnace should be located in the same room as the central system and as close as possible, but not closer than 9". There should be no wall between the furnace and the warm air outlet duct that is connected directly to the warm air outlet plenum of the central furnace.
2. Place the furnace on a noncombustible floor.
3. Ensure you have the clearances shown in this manual from the furnace and the connector pipe to combustible surfaces. If you have a solid brick or stone wall behind your furnace, you can place the furnace as close as you wish to the wall. If the wall is only faced with brick or stone, treat it as a combustible wall.

A	Unit to Sidewall	12" (305mm)
B	Unit to Backwall	30" (760mm)
C	Front of Unit to Combustible	48" (1.22m)
D	Chimney Pipe to Sidewall	21" (530mm)
E	Chimney Pipe to Backwall	18" (460mm)
F	Plenum to Combustibles	6" (150mm)

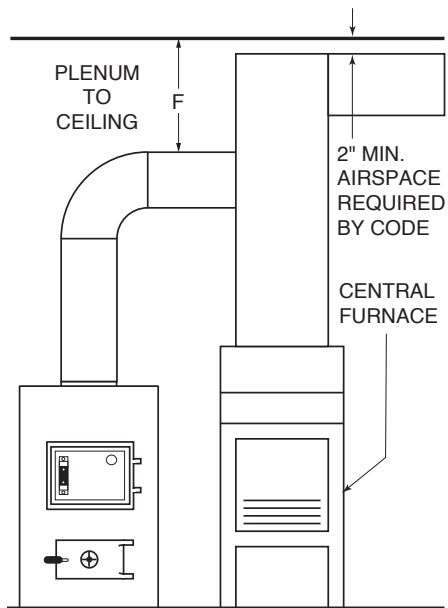

LISTED FACTORY BUILT CHIMNEY

Carefully follow chimney manufacturer's instructions. Use only a Listed Residential Type or Building Heating Appliance Chimney. If your chimney starts at the ceiling, you will need enough 6" pipe to reach the ceiling. The top of the chimney must be at least 3 feet above the roof and be at least 2 feet higher than any point of the roof within 10 feet.

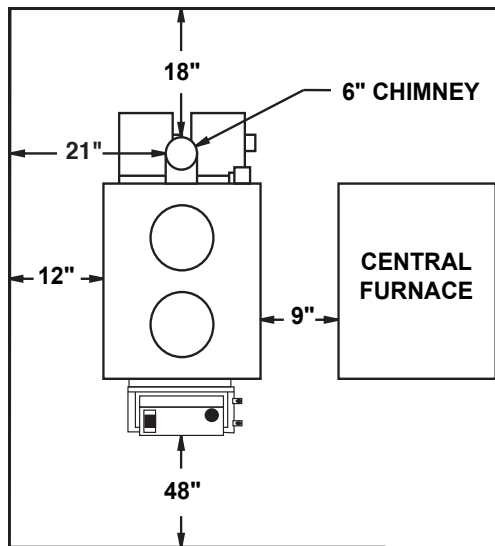
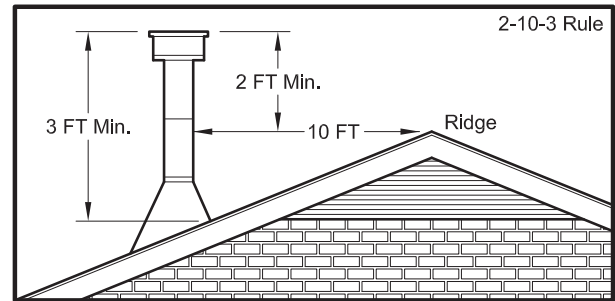

IMPORTANCE OF PROPER DRAFT

Draft is the force which moves air from the appliance up through the chimney. The amount of draft in your chimney depends on the length of the chimney, local geography, nearby obstructions and other factors. Too much draft may cause excessive temperatures in the appliance. Inadequate draft may cause backpuffing into the room and 'plugging' of the chimney. Inadequate draft will cause the appliance to leak smoke into the room through appliance and chimney connector joints. An uncontrollable burn or excessive temperature indicates excessive draft. Take into account the chimney's location to ensure it is not too close to neighbors or in a valley which may cause unhealthy or nuisance conditions.

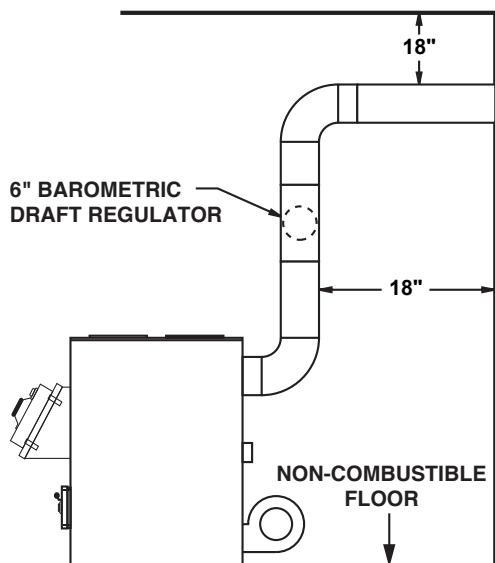

MASONRY CHIMNEY

CAUTION:

BE SURE THAT IF A MASONRY CHIMNEY IS USED, IT IS SAFELY CONSTRUCTED AND IN GOOD REPAIR. HAVE THE CHIMNEY INSPECTED BY THE FIRE DEPARTMENT OR AN INSPECTOR.

Ensure that a masonry chimney meets the minimum standards of the National Fire Protection Association (NFPA) by having it inspected by a professional. Make sure there are no cracks, loose mortar or other signs of deterioration and blockage. Have the chimney cleaned before the furnace is installed and operated. When connecting the furnace through a combustible wall to a masonry chimney, special methods are needed as explained in the "Combustible Wall Chimney Connector Pass-Throughs" Section.

WARNING:

DO NOT CONNECT THIS FURNACE TO A CHIMNEY FLUE SERVING ANOTHER APPLIANCE.

The chimney used for a furnace must not be used to ventilate the cellar or basement. If there is a cleanout opening at the base of the chimney, close it tightly.

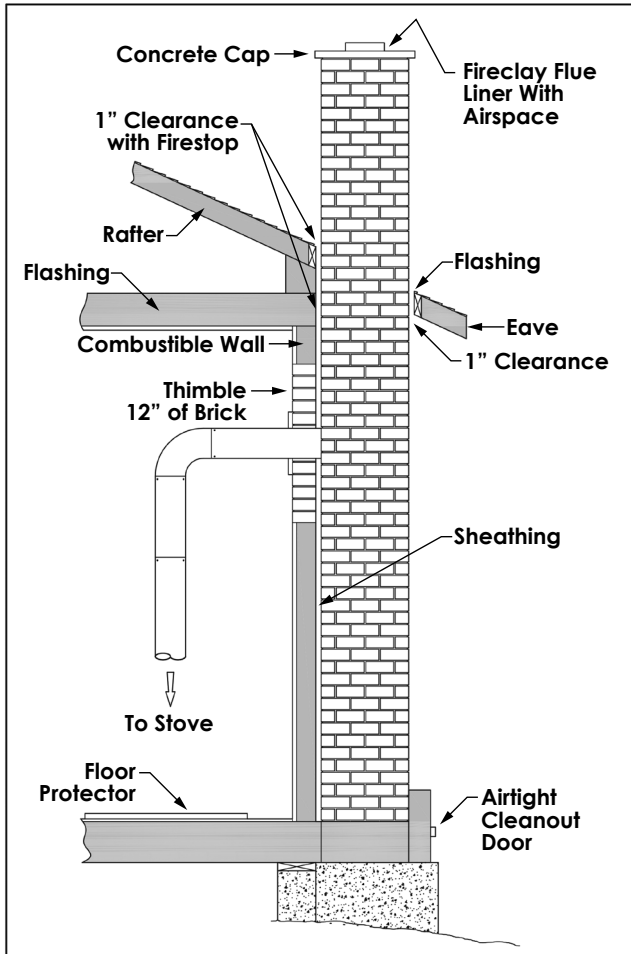

COMBUSTIBLE WALL CHIMNEY CONNECTOR PASS-THROUGHS

Method A - 12" (304.8 mm) Clearance to Combustible Wall Member: Using a minimum thickness 3.5" (89 mm) brick and a 5/8" (15.9 mm) minimum wall thickness clay liner, construct a wall pass-through. The clay liner must conform to ASTM C315 (Standard Specification for Clay Fire Linings) or its equivalent. Keep a minimum of 12" (304.8 mm) of brick masonry between the clay liner and wall combustibles. The clay liner shall run from the brick masonry outer surface to the inner surface of the chimney flue liner but not past the inner surface. Firmly grout or cement the clay liner in place to the chimney flue liner.

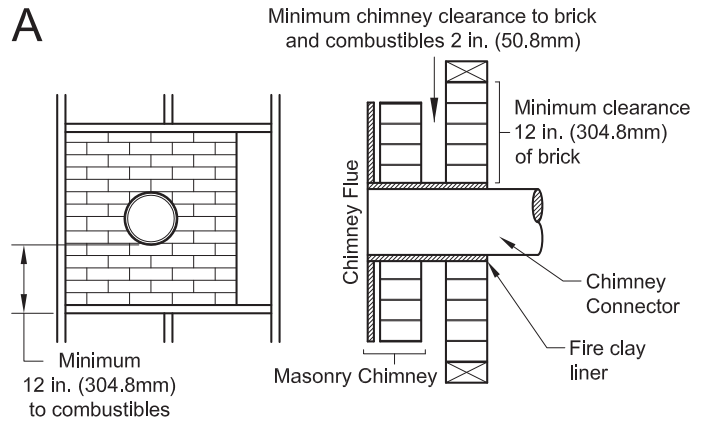

Method B - 9" (228.6 mm) Clearance to Combustible Wall Member: Using a 6" (152.4 mm) inside diameter, listed, factory-built Solid-Pak chimney section with insulation of 1" (25.4 mm) or more, build a wall pass-through with a minimum 9" (228.6 mm) air space between the outer wall of the chimney length and wall combustibles. Use sheet metal supports fastened securely to wall surfaces on all sides, to maintain the 9" (228.6 mm) air space. When fastening supports to chimney length, do not penetrate the chimney liner (the inside wall of the Solid-Pak chimney). The inner end of the Solid-Pak chimney section shall be flush with the inside of the masonry chimney flue, and sealed with a non-water soluble refractory cement. Use this cement to also seal to the brick masonry penetration.

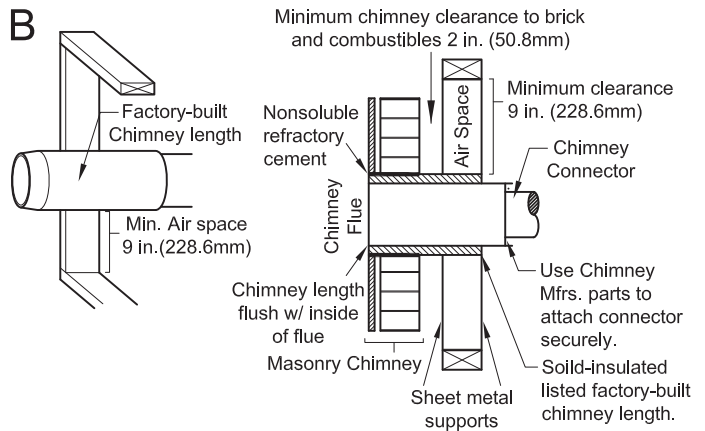

Method C - 6" (152.4 mm) Clearance to Combustible Wall Member: Starting with a minimum 24 gauge (.024" [.61 mm]) 6" (152.4 mm) metal chimney connector, and a minimum 24 gauge ventilated wall thimble which has two air channels of 1" (25.4 mm) each, construct a wall pass-through. There shall be a minimum 6" (152.4 mm) separation area containing fiberglass insulation, from the outer surface of the wall thimble to wall combustibles. Support the wall thimble, and cover its opening with a 24-gauge minimum sheet metal support. Maintain the

6" (152.4 mm) space. There should also be a support sized to fit and hold the metal chimney connector. See that the supports are fastened securely to wall surfaces on all sides. Make sure fasteners used to secure the metal chimney connector do not penetrate chimney flue liner.

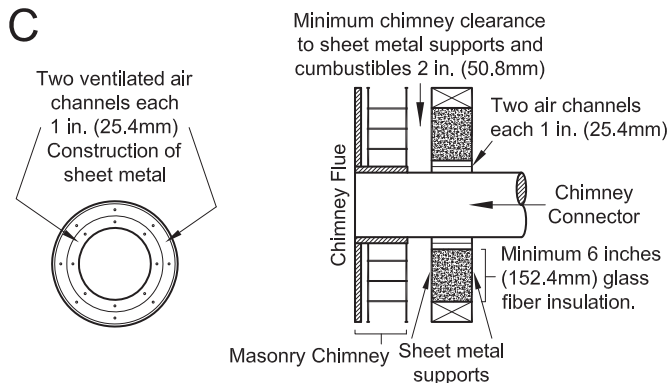

Method D - 2" (50.8 mm) Clearance to Combustible Wall Member: Start with a solid-pak listed factory built chimney section at least 12" (304 mm) long, with insulation of 1" (25.4 mm) or more, and an inside diameter of 8" (2 inches [51 mm] larger than the 6" [152.4 mm] chimney connector). Use this as a pass-through for a minimum 24-gauge single wall steel chimney connector. Keep solid-pak section concentric with and spaced 1" (25.4 mm) off the chimney connector by way of sheet metal support plates at both ends of chimney section. Cover opening with and support chimney section on both sides with 24 gauge minimum sheet metal supports. See that the supports are fastened securely to wall surfaces on all sides. Make sure fasteners used to secure chimney flue do not penetrate flue liner.

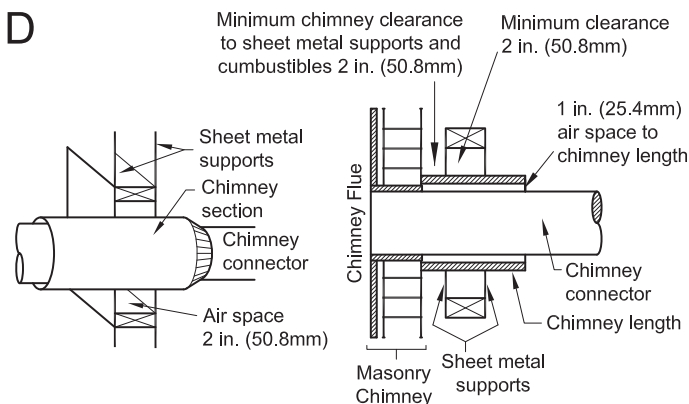

NOTES: Connectors to a masonry chimney, excepting method B, shall extend in one continuous section through the wall pass-through system and the chimney wall, to

but not past the inner flue liner face. A chimney connector shall not pass through an attic or roof space, closet or similar concealed space, or a floor, or ceiling.

CHIMNEY CONNECTOR

- Your chimney connector and chimney must have the same diameter as the furnace outlet. If this is not the case, we recommend you contact your dealer in order to ensure there will be no problem with the draft.
- The furnace pipe must be made of aluminized or cold roll steel with a minimum thickness of 0.021" or 0.53 mm. It is strictly forbidden to use galvanized steel.
- Your connector should be assembled in such a way that the male section (crimped end) of the pipe faces down. Attach each of the sections to one another with three equidistant metal screws. Seal the joints with furnace cement.
- The pipe must be short and straight. All sections installed horizontally must slope at least 1/4 inch per foot, with the upper end of the section toward the chimney. Any installation with a horizontal run of furnace pipe must conform to NFPA 211. You may contact NFPA (National Fire Protection Association) and request the latest edition of the NFPA Standard 211.
- To ensure a good draft, the total length of the furnace pipe should never exceed 8' to 10' (2.4m to 3.04 m). (Except for cases of vertical installation, cathedral-roof style where the smoke exhaust system can be much longer and connected without problem to the chimney at the ceiling of the room).
- There should never be more than two 90 degree elbows in the smoke exhaust system.
- Installation of a "barometric draft stabilizer" (fireplace register) on a smoke exhaust system is prohibited.
- Do not use with a flue damper. With a controlled combustion coal furnaces the draft is regulated upon intake of the combustion air in the furnace and not at the exhaust.

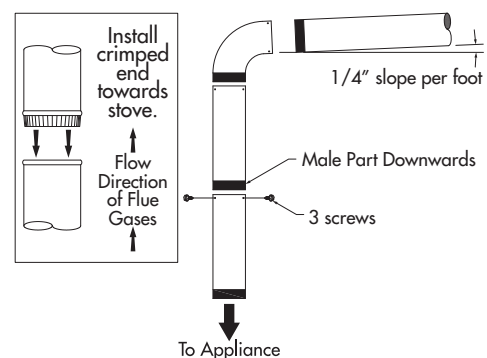

- The chimney connector must not extend into the chimney flue.

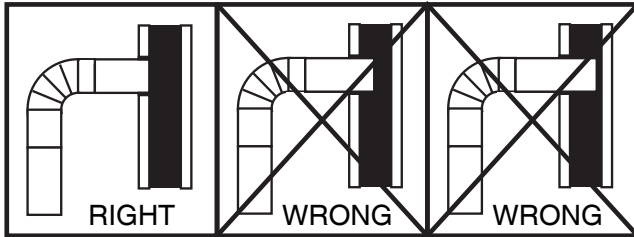

- The chimney connector may include a section for a barometric draft regulator between the furnace and the chimney. The barometric draft regulator must be installed in the same room (same pressure zone) as the furnace.

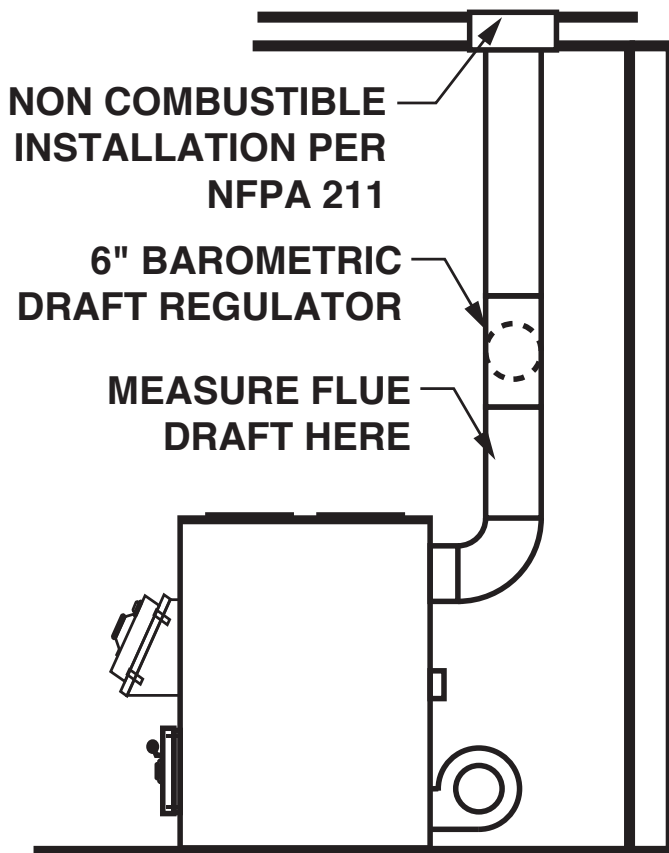

- Install the barometric draft regulator strictly in accordance with the instructions that are provided with the barometric draft regulator.

This is a furnace, not a free standing stove. You must direct heated air from 8" outlets away from the furnace, or it will not function properly.

1. This installation must be done by a qualified heating equipment installer.

2. Installation for Supplemental Heat Application to Existing Central System.

- a. Place Coal Burning Furnace so that the chimney connector will be as short as practical and avoiding unnecessary sharp turns in the smoke pipe connector and the installation of devices that would create excessive resistance to the flow of flue gases.
- b. Locate the Coal Burning Furnace as close as practical to the existing central hot air heating system, maintaining clearances as stated on the label on the fuel door.
- c. Clearance from combustible materials must comply with those stated on the label on the side of the unit. Refer to the clearance table in the front of this manual. The installation must be made only on a noncombustible floor.
- d. Install the smoke pipe connector to the chimney with 26-gauge pipe and elbows (to be purchased separately), maintaining the proper clearances for the specific model. Seal the smoke pipe in the chimney with furnace cement. (The chimney connector shall be securely supported, and joints fastened with sheet metal screws or rivets.)
- e. Install 8" diameter heat pipe to plenum of the central hot air furnace. Use 26-gauge pipe and connectors (to be purchased separately). If central air conditioning is installed in the plenum, install heat pipe above the air conditioning unit. Secure heat pipe connection with supports and sheet metal screws.
- f. Connect electrical supply in the electrical junction box that is mounted on the back of the Furnace. See Wiring Diagram. Remove the cover from electrical junction box and connect power supply wires to wires designated, using wire nuts. The power cord supplied may be used for installation, if permitted by local codes and regulations. If the power cord supplied cannot be used, the power supply wiring must be 90 degrees centigrade in a metal cable and should be completed by a qualified installer complying with NFPA Standard No. 70 and local codes.

METHODS OF INSTALLATION.

CENTRAL INSTALLATION

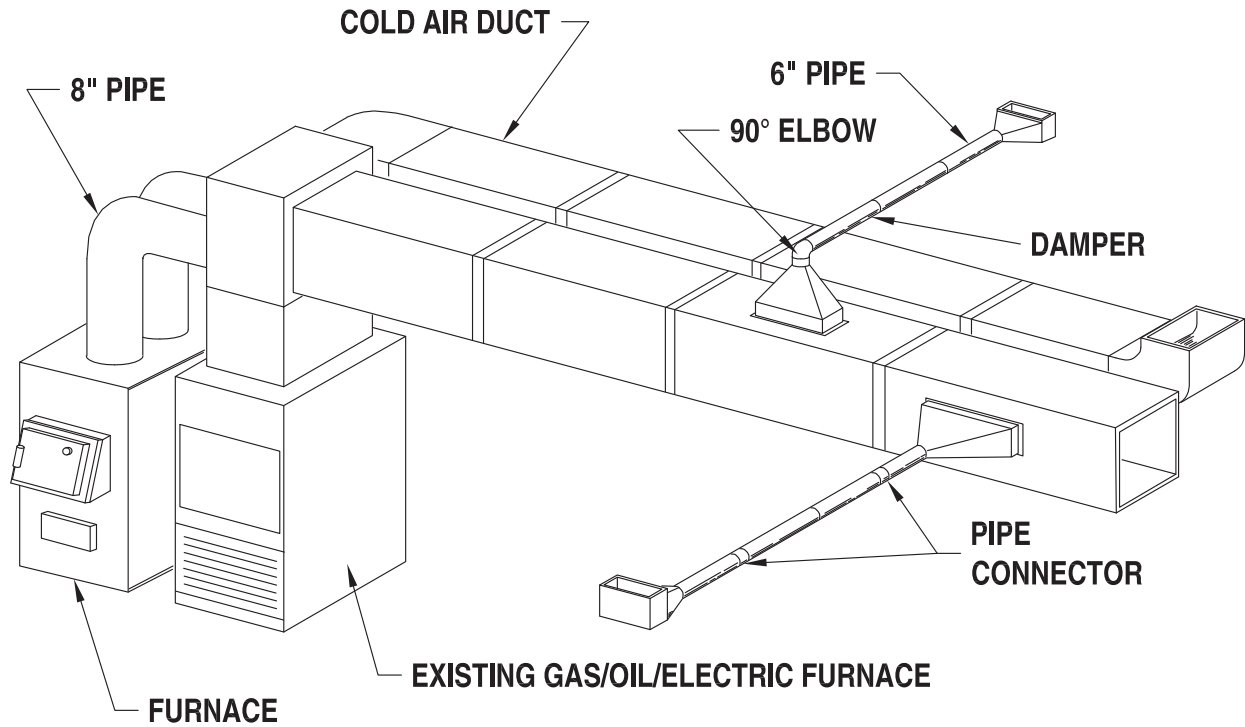

ADD-ON INSTALLATION

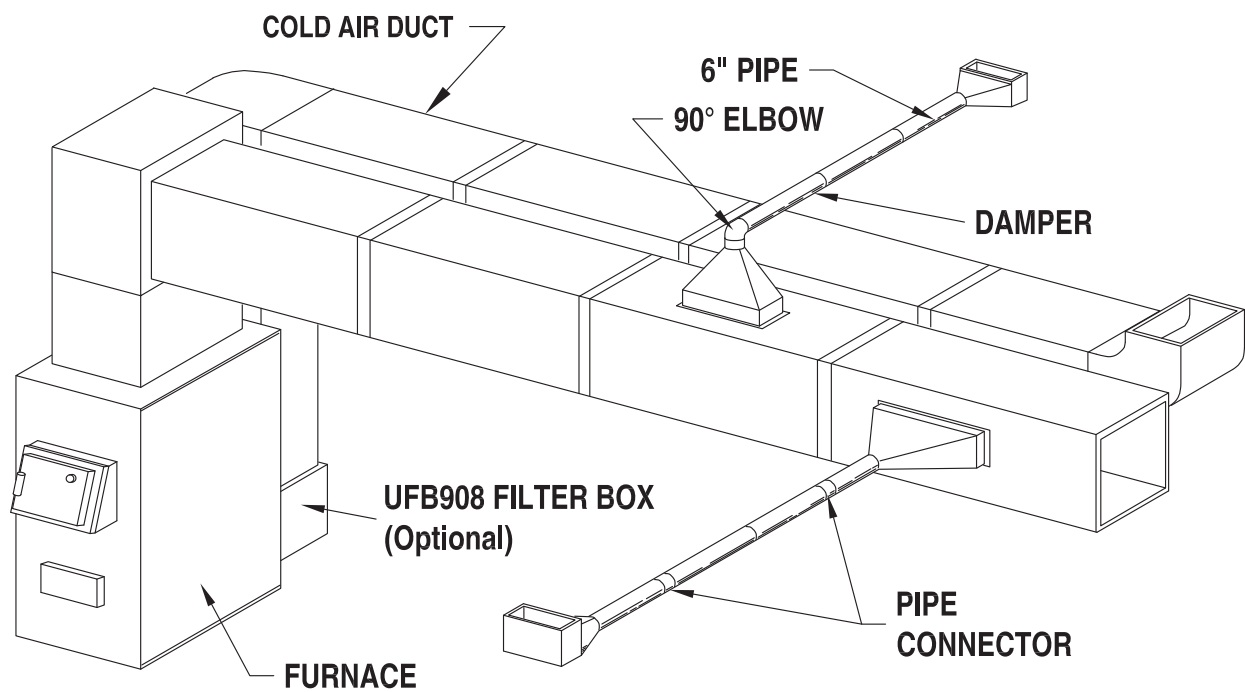

INSTALLATION A

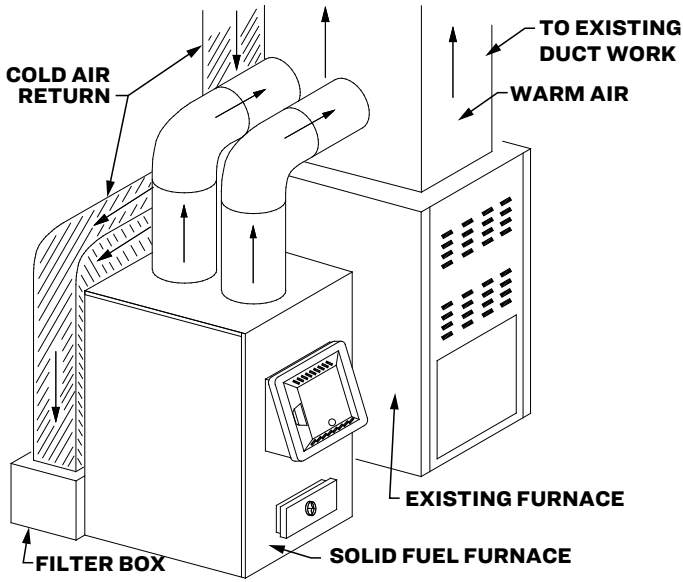

INSTALLATION C

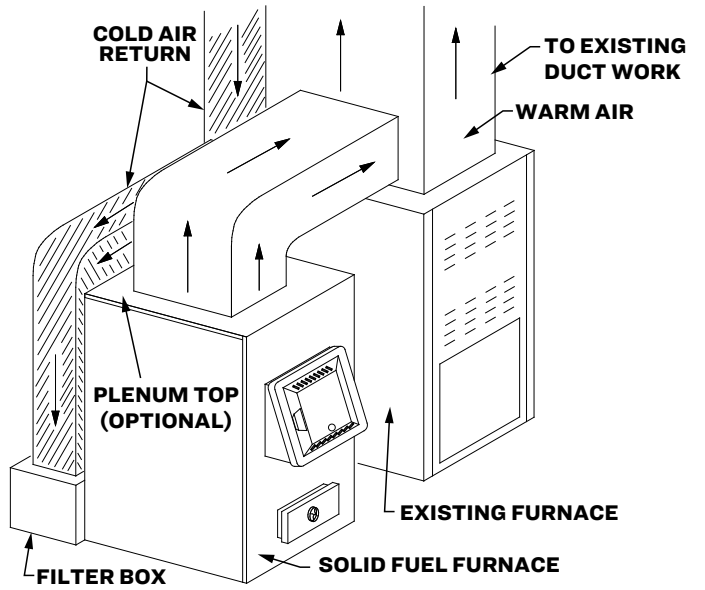

INSTALLATION B

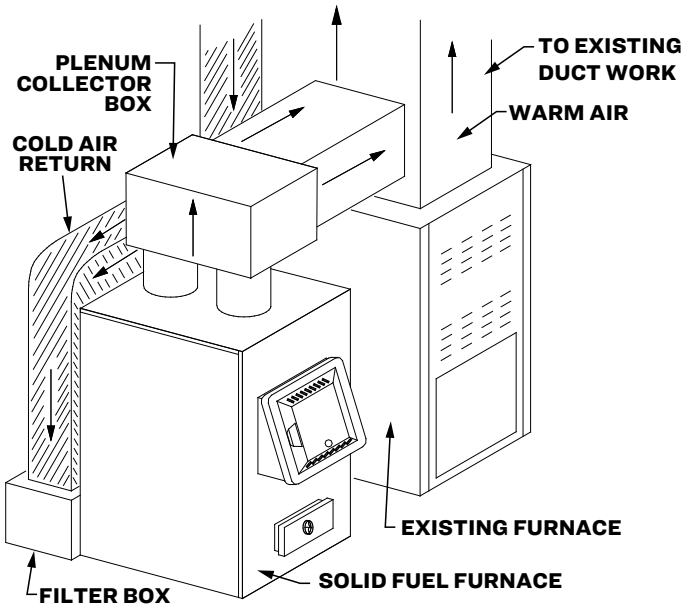

INSTALLATION D

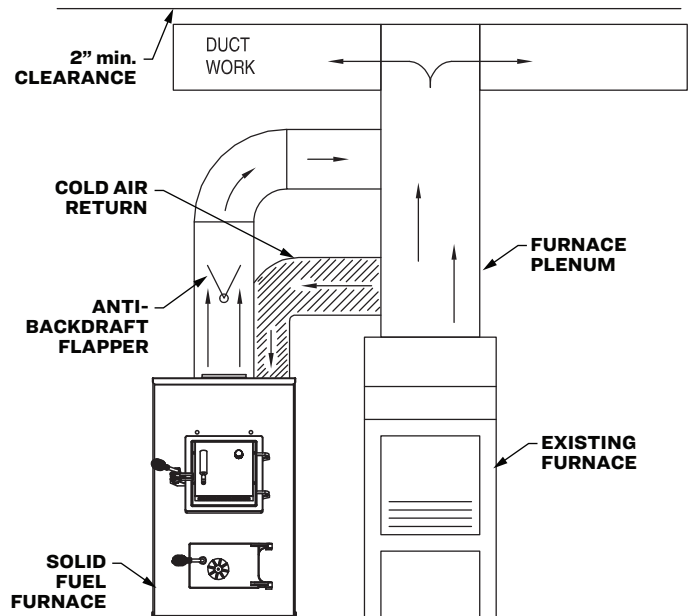

INSTALLATION E

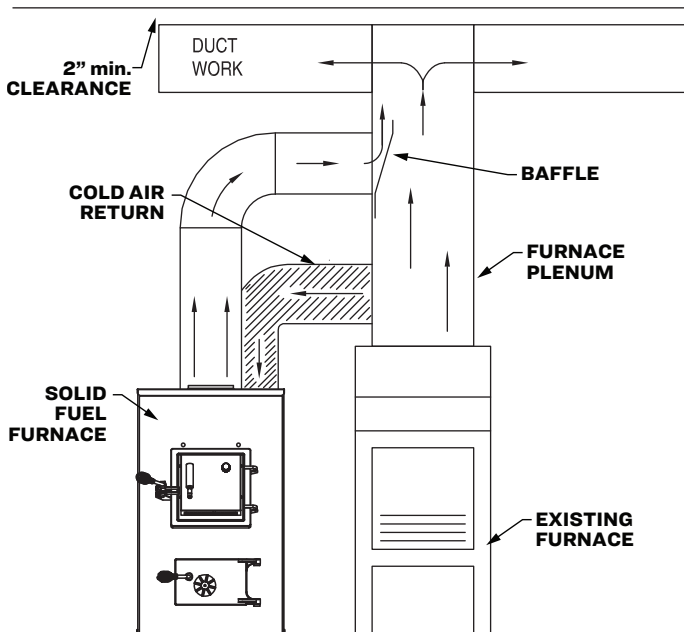

INSTALLATION G

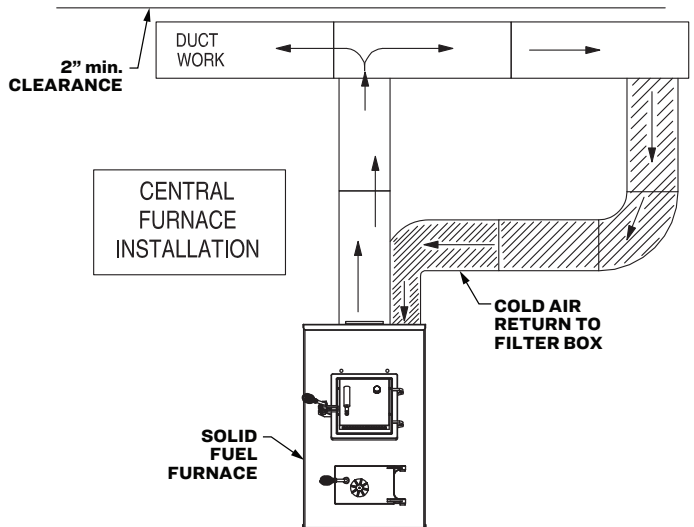

INSTALLATION F

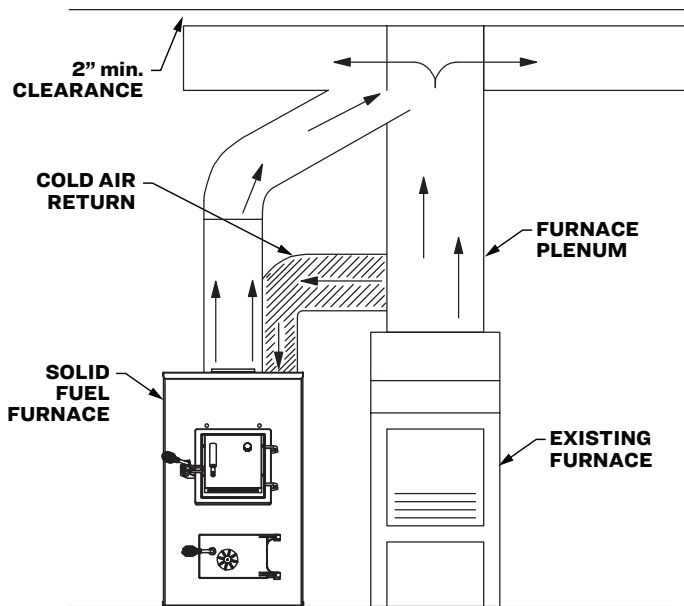

INSTALLATION H

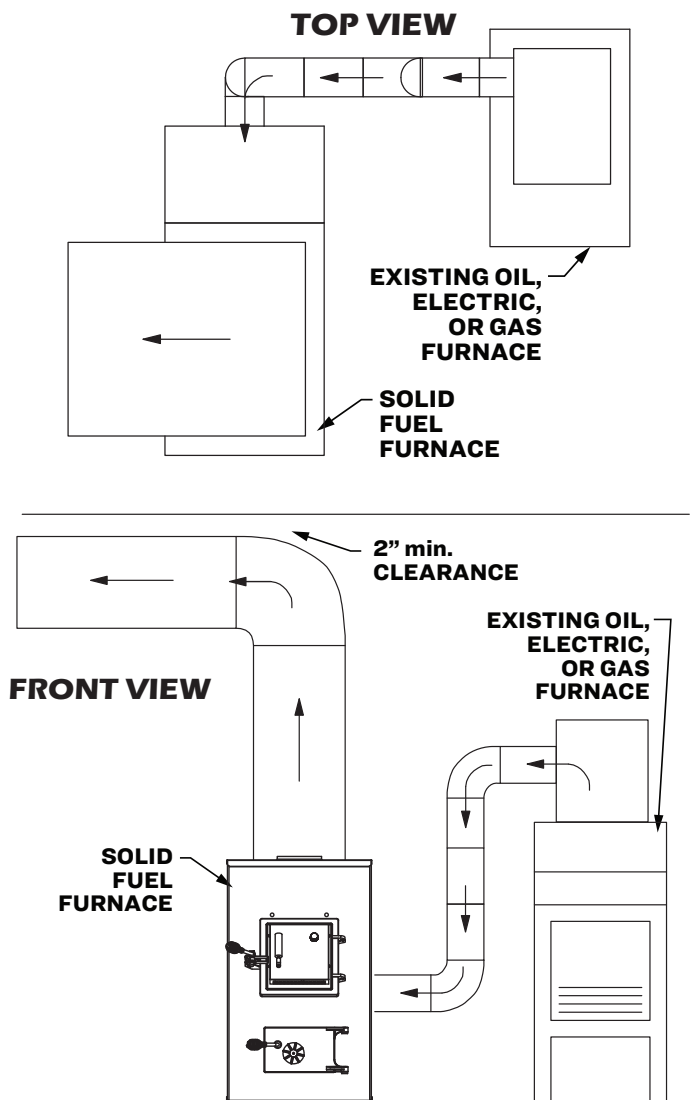

CAUTION

- **DO NOT OPERATE WITH THE FEED AND/OR ASH DOOR OPEN. THIS FURNACE IS DESIGNED FOR THERMOSTATIC OPERATION. OPERATION WITH ANY OF THESE DOORS OPEN WILL OVERHEAT AND DAMAGE THE FURNACE.**
- **KEEP THE ASH PIT SECTION FREE OF EXCESS ASHES. DO NOT ALLOW ASHES TO STACK HIGHER THAN THE SIDES OF THE ASH PAN.**
- **KEEP THE FEED AND ASH DOORS CLOSED AT ALL TIMES EXCEPT WHILE TENDING THE FURNACE.**

DO NOT OPERATE WITH FUEL LOADING OR ASH REMOVAL DOORS OPEN.

CAUTION

NEVER USE GASOLINE, GASOLINE-TYPE LANTERN FUEL, KEROSENE, CHARCOAL LIGHTER FLUID, OR FLAMMABLE LIQUIDS TO START OR "FRESHEN UP" A FIRE IN THE FURNACE.

WARNING

NEVER STORE FLAMMABLE LIQUIDS, ESPECIALLY GASOLINE, IN THE VICINITY OF THE FURNACE.

The top down method of fire building is recommended for this appliance. **DO NOT BURN:**

1. Garbage;
2. Lawn clippings or yard waste;
3. Materials containing rubber, including tires;
4. Materials containing plastic;
5. Waste petroleum products, paints or paint thinners, or asphalt products;
6. Materials containing asbestos;
7. Construction or demolition debris;
8. Railroad ties or pressure-treated wood;
9. Manure or animal remains;
10. Saltwater driftwood or other previously saltwater saturated materials;

Burning these materials may result in release of toxic fumes or render the heater ineffective and cause smoke.

POWER FAILURE

After loss of power remove the filter if provided and do not expect to keep home at normal temperatures.

ADJUSTING THE BAROMETRIC DRAFT REGULATOR

1. Drill a hole in the chimney connector within 18" of the flue collar below the barometric draft regulator just large enough for the tube of the manometer.
2. Build a fire after all chimney connections have been made.
3. Use a manometer to measure the draft in the flue.
4. Adjust the Barometric Draft Regulator to obtain a draft of 0.05 - 0.06" W.C. under stable fire conditions.

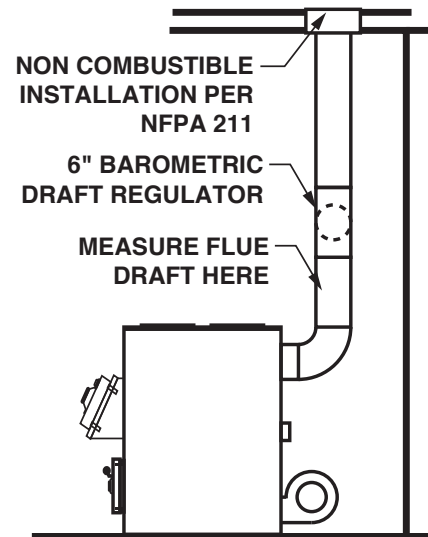

TAMPER WARNING

This coal heater has a manufacturer-set minimum low burn rate that must not be altered.

VISIBLE SMOKE

The amount of visible smoke being produced can be an effective method of determining how efficiently the combustion process is taking place at the given settings. Visible smoke consist of unburned fuel and moisture leaving your stove. Learn to adjust the air settings of your specific unit to produce the smallest amount of visible smoke.

OVER FIRING

Attempts to achieve heat output rates that exceed heater design specifications can result in permanent damage to the heater.

ASH REMOVAL & DISPOSAL

Whenever ashes get 3 to 4 inches deep in your firebox or ash pan, and when the fire has burned down and cooled, remove excess ashes. Leave an ash bed approximately 1 inch deep on the firebox bottom to help maintain a

hot charcoal bed. Ashes should be placed in a metal container with a tight-fitting lid. The closed container of ashes should be placed on a noncombustible floor or on the ground, away from all combustible materials, pending final disposal. The ashes should be retained in the closed container until all cinders have thoroughly cooled.

SMOKE & CO MONITORS

CO is a poisonous gas when exposed to elevated concentrations for extended periods of time. While the modern combustion systems in heaters drastically reduce the amount of CO emitted out the chimney, exposure to the gases in closed or confined areas can be dangerous. Make sure your stove gaskets and chimney joints are in good working order and sealing properly to ensure unintended exposure. It is recommended that you use both smoke and CO monitors in areas having the potential to generate CO.

GASKETS

It is recommended that you change the door gasket (which makes your stove door air tight) once a year, in order to ensure good control over the combustion, maximum efficiency and security. To change the door gasket, simply remove the damaged one. Carefully clean the available gasket groove, apply a high temperature silicone sold for this purpose, and install the new gasket. You may light up your stove again approximately 24 hours after having completed this operation. This unit's ash door uses a 5/8" diameter rope gasket. This unit's feed door uses a 1/2" diameter rope gasket.

SERVICE HINTS

Do not expect a furnace to draw. It is the chimney that creates the draft. Smoke spillage into the house or excessive build-up of water or creosote in the chimney are warnings that the chimney is not functioning properly. Correct the problem before using furnace. Possible causes are:

1. The connector pipe may be pushed into the chimney too far, stopping the draft.
2. Do not connect two furnaces or a stove and furnace into the same chimney flue.
3. The chimney used for a furnace must not be used to ventilate the cellar or basement. If there is a cleanout opening at the base of the chimney, it must be closed tightly.
4. If the chimney is operating too cool, water will condense in the chimney and run back into the furnace. Creosote formation will be rapid and may

block the chimney. Operate the furnace at a high enough fire to keep the chimney warm, preventing this condensation.

5. If the fire burns well, but sometimes smokes or burns slowly, it may be caused by the chimney top being lower than another part of the house or a nearby tree. The wind blowing over a house or a tree, falls on top of the chimney like water over a dam, beating down the smoke. The top of the chimney should be at least 3 feet above the roof and be at least 2 feet higher than any point of the roof within 10 feet.

CREOSOTE & SOOT - FORMATION & NEED FOR REMOVAL

When coal is burned, the products of combustion combine with moisture to form a soot residue which accumulates on the flue lining. When ignited, this soot makes an extremely hot fire. The chimney should be inspected at least twice monthly during the heating season to determine if a creosote or soot build up has occurred. If creosote or soot has accumulated, it should be removed to reduce the risk of a chimney fire. Chimney fires burn very hot. If the chimney catches fire, immediately call the fire department, then reduce the fire by closing the inlet air control. Pour a large quantity of coarse salt, baking soda or cool ashes on top of the fire in the firebox.

CREOSOTE ACCUMULATION CAUSES CHIMNEY FIRES. YOU SHOULD CHECK (OR HAVE CHECKED BY A QUALIFIED CHIMNEY SWEEP) YOUR CHIMNEY FOR CREOSOTE DEPOSITS AT LEAST MONTHLY DURING THE HEATING SEASON. ANY ACCUMULATIONS SHOULD BE REMOVED. COMPLETE CHIMNEY INSPECTIONS AND CLEANING SHOULD BE CONDUCTED ANNUALLY; TYPICALLY, THIS TASK SHOULD BE PERFORMED PRIOR TO EACH HEATING SEASON. IF USING AN EXISTING CHIMNEY, IT MUST BE INSPECTED PRIOR TO THE INSTALLATION OF YOUR NEW WOOD STOVE.

CAUTION

A CHIMNEY FIRE MAY CAUSE IGNITION OF WALL STUDS OR RAFTERS WHICH YOU THOUGHT WERE A SAFE DISTANCE FROM THE CHIMNEY. IF YOU HAVE A CHIMNEY FIRE, HAVE YOUR CHIMNEY INSPECTED BY A QUALIFIED PERSON BEFORE USING AGAIN.

OPERATION

ATTENTION:

A DRAFT READING OF .05 TO .06 W.C. IS SUGGESTED FOR PROPER BURNING OF THIS UNIT WHEN USING BITUMINOUS COAL AS FUEL. WHEN USING ANTHRACITE COAL, THIS DRAFT READING IS A MINIMUM READING.

ATTENTION:

THIS HEATER NEEDS PERIODIC INSPECTION AND REPAIR FOR PROPER OPERATION. IT IS AGAINST FEDERAL REGULATIONS TO OPERATE THIS HEATER IN A MANNER INCONSISTENT WITH OPERATING INSTRUCTIONS IN THIS MANUAL.

CARING FOR PAINTED PARTS

This furnace has a painted outside jacket, which is durable, but it will not stand rough handling or abuse.

When installing your furnace, use care in handling. Clean with soap and warm water when furnace is not hot. DO NOT use any acids or scouring soap, as these wear and dull the finish. DISCOLORATION WILL OCCUR IF THE FURNACE IS OVERHEATED. FOLLOW OPERATING INSTRUCTIONS CAREFULLY.

CAUTION:

THE SPECIAL PAINTS USED ON YOUR FURNACE MAY GIVE OFF SOME SMOKE WHILE THEY ARE CURING DURING FIRST FEW FIRES., BUILD SMALL FIRES AT FIRST. THE METAL USED IN CONSTRUCTION OF THE FURNACE AND DUCT WORK HAS A LIGHT COATING OF OIL. THIS COULD GIVE OFF SMOKE AND/OR ODOR FROM REGISTERS WHEN FURNACE IS USED FOR THE FIRST TIME. THIS SHOULD DISAPPEAR AFTER A SHORT PERIOD OF TIME. ONCE THIS BURN-OFF HAS OCCURRED, IT SHOULD NOT REOCCUR.

WIRING DIAGRAM

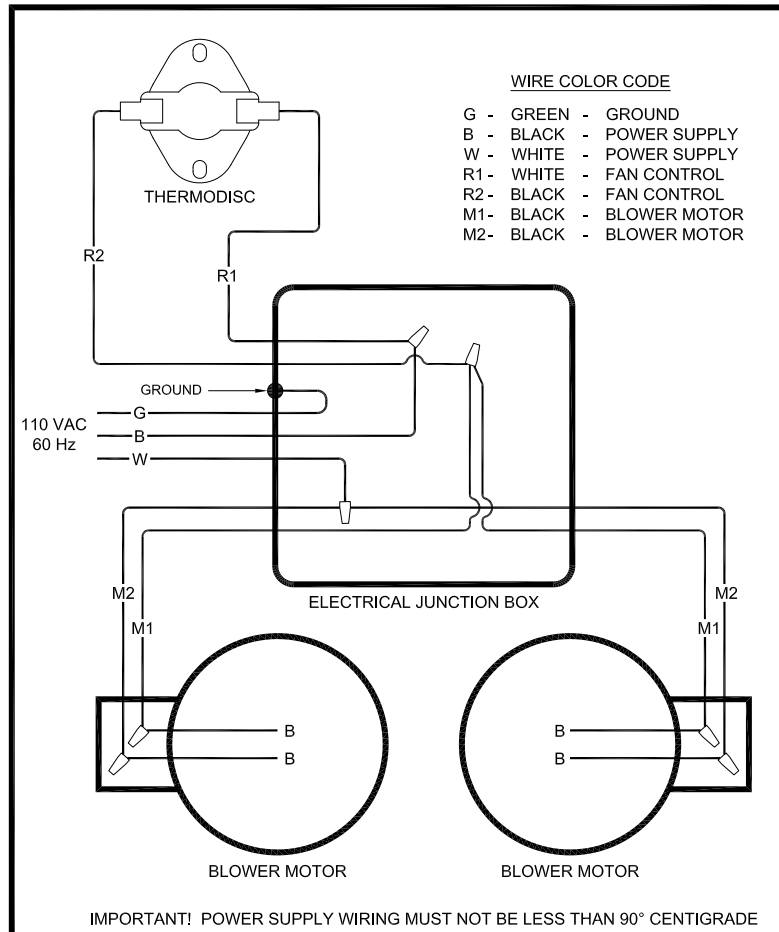

Problem:	Solution
Smoke puffs from furnace	<p>Check chimney draft. Check for blocked chimney or flue pipe. Use mirror to check chimney clearance.</p> <p>Check ash pit — if it is too full, empty.</p> <p>Make sure furnace room is not too airtight.</p> <p>Make sure all of chimney mortar connections are airtight.</p> <p>Check ash drawer. Make sure it's airtight.</p> <p>Check chimney for possible down-draft caused by taller surrounding trees or objects. Correct with proper chimney vent cap.</p> <p>Check the possibility of a cold chimney forcing cool gases backward. Remedied by properly insulating chimney with non-combustible liner — non-combustible insulation.</p> <p>Fuel may be too green.</p> <p>Make sure no other fuel burning devices are connected to the chimney impairing the draft.</p> <p>Check chimney draft, it should be .06 inches of water column. This service is provided by a certified chimney sweep.</p>
Inadequate heat being delivered to your home	<p>Check home insulation — is it adequate?</p> <p>Check hook-up to furnace — is it installed correctly?</p> <p>Cool air inlet may be inadequate or furnace room too airtight.</p> <p>Make sure your hot air duct (and other duct work) is airtight.</p> <p>If furnace room is warm but your home isn't, check back draft dampers.</p> <p>Is air to the blower available?</p>
Excess smoke or flames coming out door when refueling	<p>Wait 15 seconds and open door SLOWLY — then refuel.</p> <p>Check length of flue pipe to chimney. Your unit should be within six (6) feet of your chimney.</p> <p>Make sure chimney cap is not too close to the top of the chimney.</p> <p>Check chimney draft — make sure chimney flue pipe is clean and chimney is of adequate height.</p> <p>Slide baffle should be pulled out prior to load door opening.</p>
Distribution blower vibrating	<p>Tighten blower wheel to motor shaft.</p> <p>Check for bad fan bearings.</p>
Distribution blower continues to run or will not run	<p>Check fan limit or heat sensor and cable.</p> <p>Check to see that blower is properly wired. (See Wiring and Assembly Instructions).</p> <p>Check fuse box or power source.</p> <p>Check power supply.</p>
Odor from first fire	<p>The odor from new steel should disappear in a few hours.</p> <p>If the odor remains, call you dealer immediately. A bad weld can cause a fume leak.</p>
Excessive Creosote	<p>Make sure your unit is serviced by its own proper chimney.</p> <p>Check length of flue pipe and its connections.</p> <p>Make sure you are burning the smallest, hottest fire to adequately heat your home.</p> <p>Also see Solutions to Problem one.</p>
If the fire goes out or does not hold over night	<p>Poor Draft.</p> <p>Incorrect damper settings.</p> <p>Improper firing methods if burning coal.</p> <p>More combustion air needed.</p> <p>Coal not sized to the furnace. We recommend 1" to 3" diameter pieces of coal.</p> <p>Ashes, if allowed to accumulate in the ash pit, will not allow passage of the required air for combustion. Keep ash pit clean.</p> <p>This furnace is not to be used with an automatic stoker unless so certified.</p>

Furnaces that are capable of burning coal usually will burn both Bituminous and Anthracite coal. Anthracite is perhaps the best coal fuel because of its long even burn time, high heat output, and cleanliness which make it a good choice for the home. However, keep in mind it is a much more difficult fuel to use, requires more care and patience, is not so widely available, and is usually much more expensive than Bituminous.

SIZE OF COAL

Most sizes of Bituminous Coal will work in a coal furnace; for best results we recommend large “nut” coal to small “egg” coal (1-3/4” diameter to 4” diameter). When burning Anthracite, use “egg” or “broken” with sizes between 2-5/16” thru 4-3/8”. Note that it is important to the long life of your stove to buy coal which has been sized and cleaned. Cleaning ensures removal of rocks and other minerals. Never use coal smaller than 1” or larger than 5” in diameter. Small sized coal will smother the fire. Too large a size of coal will not burn well.

STOVE OPERATION

All coal fires should be started with wood which will allow the fire to get hot enough to ignite the coal. The best ignition fires utilize dry pine or other resinous soft woods as kindling, with hard wood (oak, hickory, ash) added to increase the heat prior to addition of the coal. Before starting the fire, open the stove pipe damper (if equipped), turn the thermostat to high, open the ash pit door and feed door, place newspaper and finely split kindling on the grate, light the paper, add larger hard wood after the kindling is burning brightly. Caution: Never use gasoline, lantern fuel, kerosene, charcoal lighter fluid, or other flammable liquids to start or freshen up a fire in any heater. Place the larger pieces of wood on the fire so that they are slightly separated and form a level for the addition of coal. It will take 10 to 20 minutes before this wood is thoroughly ignited. Adding coal too soon will cut the air supply and smother the fire.

BURNING BITUMINOUS

Once your kindling and wood fire has produced a bed of well established coals, start adding coal in layers allowing each to ignite before adding more. Bituminous has a high volatile content and, as a result, should be fired with the “conical method” - with the highest portion of your fire bed in the center of the firebox. The first flames will be long and generally orange or yellow and produce quite a bit of smoke. As the gases burn off the flames become shorter, change color and produce less smoke. Once the fire is WELL ESTABLISHED add coal to the center of the firebox forming the cone. Burning in this fashion

allows heat to drive off the volatile gases, and turbulence created increases the burn efficiency. There will have to be some experimenting with the individual setup as no two chimney’s or installations are going to be the same. Just remember to allow enough air to enter the firebox and keep the stove pipe damper open so that volatile substances are properly burned. Before refueling, take the time to break up the cone a little with a poker, especially if it has caked over or formed a crust. But, be careful not to mix the coal as this increases the chances of forming clinkers. When shaking the grate(s) be gentle. Just a few short movements - a couple of “cranks” - is better than a lot of agitation. The objective is to remove a small amount of the ashes without disturbing the fire. Stop when you see a glow in the ashes or the first red coals fall into the ash pan. Excessive shaking wastes fuel and can expose the grate(s) to very high temperatures which can cause warpage or burnout. For overnight operation (long duration burn time) shake the fire and add coal, retaining the center cone. Once the volatile substances are burned off, close the feed door and adjust the stove pipe damper, if equipped. Then adjust the thermostat to the desired heat level. More maintenance will be needed with bituminous coal than with anthracite coal as more soot will collect on heating surfaces and in pipes, requiring more frequent cleaning.

ANTHRACITE

Add a thin layer of coal (preferably smaller chunks) to the wood fire, being careful not to disturb it too much or cut off the draft. Then, add a second heavier layer after the coal is ignited and burning well. If necessary, add a third layer to bring the coal up to the top of the front liner (not above!). Be sure to close the ash door. Before adding further fuel, be sure to leave a red spot of glowing coals in the center of the firebox to ensure that the fire has not been smothered and to help ignite the gases given off by the new charge. A deep charge will give a more even heat and a longer fire, but it may take one to two hours before the whole bed is fully ignited. When the fire is well established and the room is becoming warm, partially close the dampers. Some experimenting will have to take place with each particular setting of all dampers and controls as the chimney provides the draft necessary to not only exhaust the smoke, but to pull combustion air into the heater as well - and no two chimney’s perform the same. Under ideal draft conditions, one should be able to turn the secondary air supply below the feed door (some models) to a near closed position - but leave the ash pit damper at least partially open to prevent the fire from going out. Adjust the stove pipe damper to reduce the draft on the fire. With anthracite there will be

short blue flames above the coal, except when the fire is started or a new charge is added. If, however, there is no flame then the fire needs more air from the bottom (unless it is near the end of its burn cycle and needs to be recharged). Only when the coal is burned down to half its original depth it is time to add fresh coal. When doing so, open the stove pipe damper and turn the thermostat damper to high, which will allow the fire to burn off any accumulated gases. Open the feed door, and with a small rake, hoe, or hooked poker pull the glowing coals to the front of the firebox. Try not to disturb the fire too much. Next, add a fresh charge to the back being careful not to seal off the top. Close the feed door, but leave the spin damper (or thermostat) open for a few minutes until the volatile gases have burned off. It is not necessary to shake down the ashes each time you refuel the furnace. Experience will be your best teacher.

BANKING THE FIRE

For extended operation, such as overnight, the fire will need to be banked. To do so heap coal up along the sides and back of the firebox so that the fire gradually burns it over a longer period of time. The intensity of the fire will also be reduced without letting it go out. Follow the same procedure to refuel. If possible, avoid shaking, as a heavier layer of ash will help reduce the intensity of the

fire during this time. After loading, let the fire establish itself for about 30 minutes. Then close your damper and automatic control to the point where the house does not become too cold. It is important that you begin banking early enough before retiring or leaving that you can make necessary adjustments after the fire is well established. To revive a coal fire that is almost out, (1) open the ash door and stove pipe damper and close the spin damper under the door to get a good draft through the grate. (2) place a thin layer of dry coal over the entire top of the fire. **DO NOT POKE OR SHAKE THE FIRE AT THIS TIME!** (3) after the fresh coal has become well ignited shake the grate (just a little), refuel.

WARNING:
<ul style="list-style-type: none"> • DO NOT BURN COKE, CHARCOAL, HIGH VOLATILE BITUMINOUS COAL, SUB BITUMINOUS, LIGNITE OR CANNEL COAL (SOMETIMES CALLED CHANNEL COAL OR CANDLE COAL). • NEVER BURN WAX OR CHEMICALLY IMPREGNATED SAWDUST LOGS - THEIR INTENDED USE IS FOR FIREPLACES ONLY. • NEVER FILL THE STOVE OR FURNACE ABOVE THE FIREBRICK OR CAST IRON LINER.

HOW TO ORDER REPAIR PARTS

For Parts Assistance, Call 800-750-2723 ext 5051 or Email: parts@usstove.com , or order at www.myreplacementparts.com

The information in this owner’s manual is specific to your unit. When ordering replacement parts the information in this manual will help to ensure the correct items are ordered. Before contacting customer service write down the model number and the serial number of this unit. That information can be found on the certification label attached to the back of the unit. Other information that may be needed would be the part number and part description of the item(s) in question. Part numbers and descriptions can be found in the “Repair Parts” section of this manual. Once this information has been gathered you can contact customer service by phone 1-800-750-2723 Ext 5051 or Email parts@usstove.com.

Model Information	
Model Number	
Serial Number	

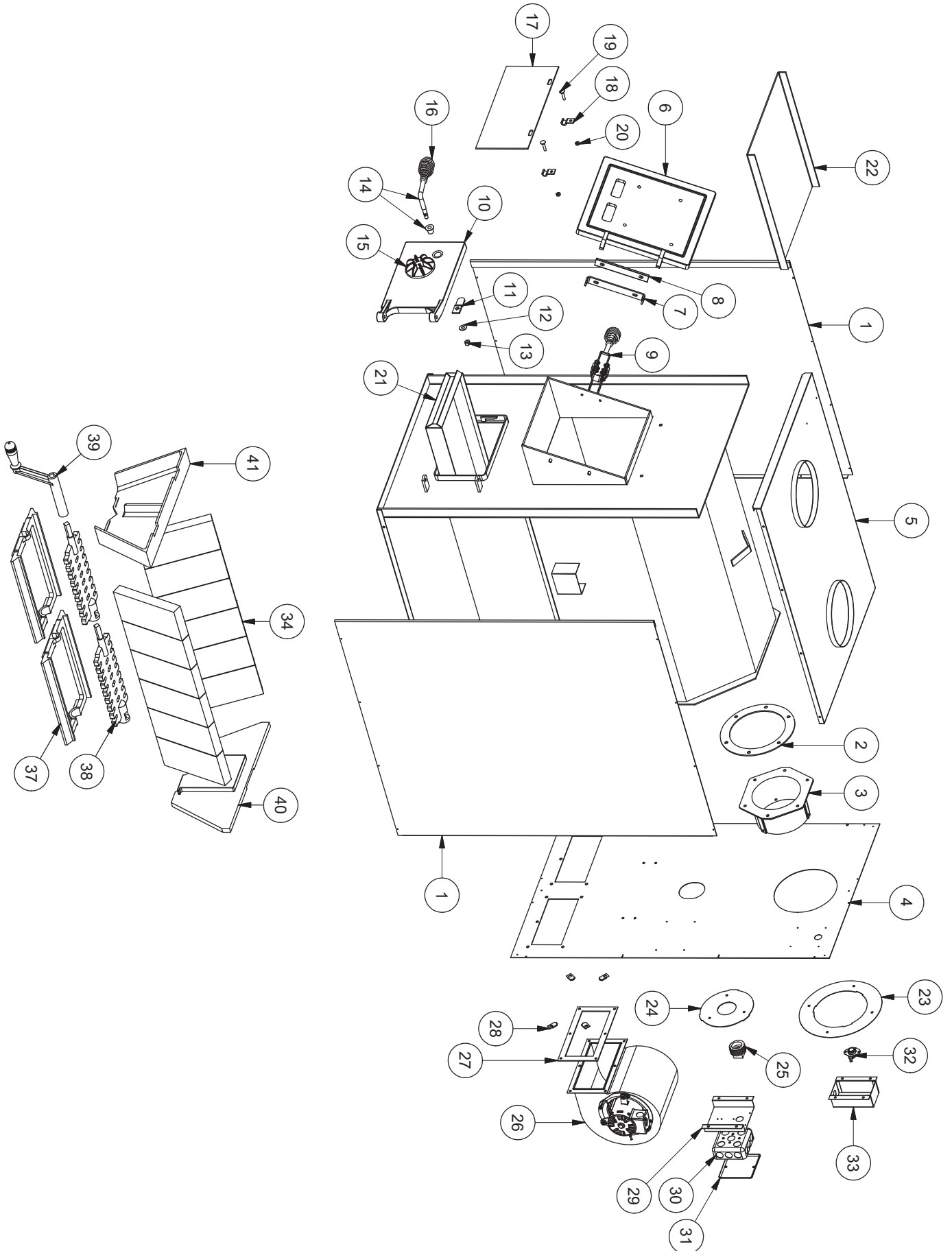

Key	Part #	Description	Qty
1	25467B	Cabinet Side (L & R)	2
2	88032	Flue Collar Gasket	2
3	40246	Flue Collar	1
4	23459B	Cabinet Back	1
5	25466B	Cabinet Top	1
N/S	891214	8" Collar	2
6	68217	Feed Door Assy.	1
7	22662	Feed Door Bracket	1
8	24232	Hinge Spacer	1
9	891097	Feed Door Locking Mechanism	1
10	68218	Ash Door Assy.	1
11	86626	Door Latch	1
12	83461	Washer (1" OD, 7/16" ID)	1
13	83274	Lock Nut, 3/8-16	1
14	891098	Handle Assy. w/Handle Bushing	1
15	23859B	Painted Draft Cap	1
16	891135	Handle, Spring	2
17	23800	Smoke Curtain	1
18	23787	Smoke Curtain Clip	2
19	83445	1/4-20 x 1-1/4 Carriage Bolt	2
20	83250	1/4-20 Kep Nut	2

Key	Part #	Description	Qty
21	68228	Ash Pan	1
22	23398	Flue Baffle	2
23	22761B	Flue Collar Ring	1
24	22762B	Forced Draft Ring	1
25	86402	1-1/2" Pipe Plug	1
26	80230	Blower	2
27	89319	Gasket, Blower	2
28	83340	1/4-20 Clipnut	8
29	22140	Relay Box Bracket	1
30	80131	Junction Box (4 x 4)	1
31	80231	Junction Box Cover	1
32	80314	Thermodisc (60T12)	1
33	68234	Blower Thermostat Bracket	1
34	89066	Firebrick (4.5 x 9 x 1.25)	12
36	40264	Front/Rear Liner	
37	40256	Shaker Grate Frame	2
38	40257	Shaker Grate	2
39	40260	Shaker Handle	1
40	40258	Liner - Front/Rear	1
41	40269	Liner - Front	1

To order parts:

Call 1-800-750-2723 Ext 5051 or

Email to: parts@usstove.com

IN ORDER TO MAINTAIN WARRANTY, COMPONENTS MUST BE REPLACED USING ORIGINAL MANUFACTURERS PARTS PURCHASED THROUGH YOUR DEALER OR DIRECTLY FROM THE APPLIANCE MANUFACTURER. USE OF THIRD PARTY COMPONENTS WILL VOID THE WARRANTY.

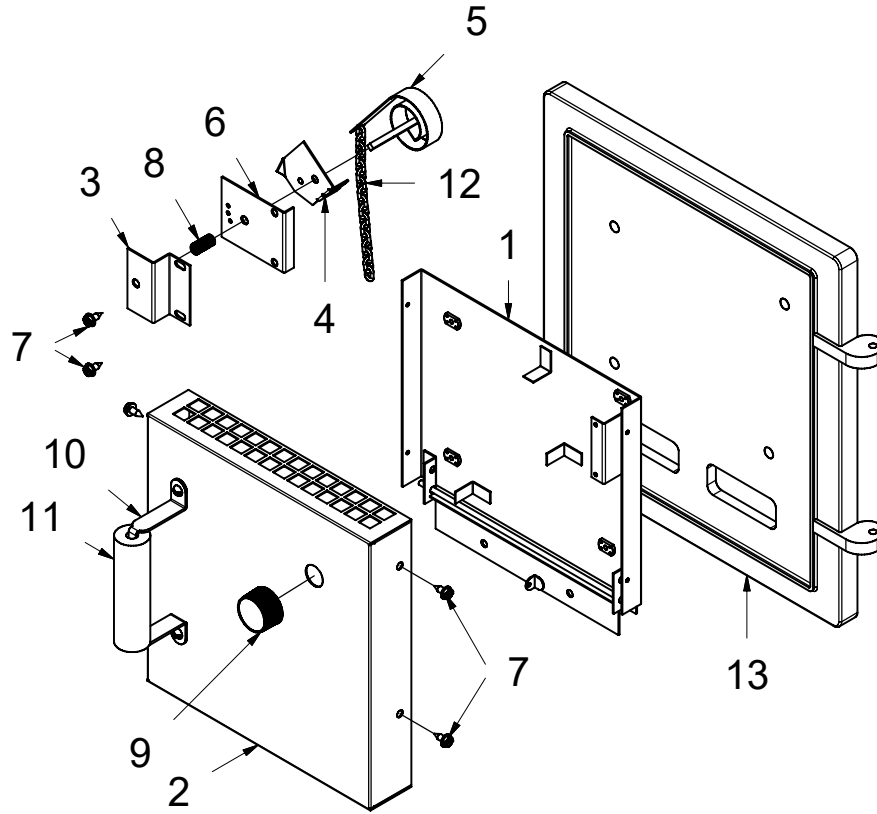

Key	Part #	Description	Qty
-	69921B	Thermostat Box Assembly	-
1	68722	Thermostat Panel Weldment	1
2	68732	Thermostat Cover Weldment (Color - Red)	1
**	68732B	Thermostat Cover Weldment	1
3	23429	Thermostat Step Plate	1
4	23431	Friction Plate	1
5	81903	Thermostat	1
6	23427	Thermostat Mounting Bracket	1
7	83172	#10 Sheet Metal Screw	6

Key	Part #	Description	Qty
8	89041	Spring	1
9	89175	Thermostat Knob	1
10	23425	Handle Bracket	2
11	89520	Wooden Handle	1
12	86318	Thermostat Chain	1/2 ft
13	68217	Feed Door Assembly (Includes Door and Gasket)	1
N/S	83106S	Machine Screw, 10-24 x 1/2" SL HD Z	2
N/S	83136	Washer, 9/32" I.D. - 5/8" O.D. - 1/16" THK.	1
N/S	83816	1/16" x 3/4" Cotter Pin	1

To order parts:

Call 1-800-750-2723 Ext 5051 or

Email to: parts@usstove.com

IN ORDER TO MAINTAIN WARRANTY, COMPONENTS MUST BE REPLACED USING ORIGINAL MANUFACTURERS PARTS PURCHASED THROUGH YOUR DEALER OR DIRECTLY FROM THE APPLIANCE MANUFACTURER. USE OF THIRD PARTY COMPONENTS WILL VOID THE WARRANTY.



SERVICE RECORD

It is recommended that your heating system is serviced regularly and that the appropriate Service Interval Record is completed.

SERVICE PROVIDER

Before completing the appropriate Service Record below, please ensure you have carried out the service as described in the manufacturer's instructions. Always use the manufacturer's specified spare part when replacement is necessary.

Service 01 Date: _____

Engineer Name: _____

License No.: _____

Company: _____

Telephone No.: _____

Stove Inspected: Chimney Swept:

Items Replaced: _____

Service 02 Date: _____

Engineer Name: _____

License No.: _____

Company: _____

Telephone No.: _____

Stove Inspected: Chimney Swept:

Items Replaced: _____

Service 03 Date: _____

Engineer Name: _____

License No.: _____

Company: _____

Telephone No.: _____

Stove Inspected: Chimney Swept:

Items Replaced: _____

Service 04 Date: _____

Engineer Name: _____

License No.: _____

Company: _____

Telephone No.: _____

Stove Inspected: Chimney Swept:

Items Replaced: _____

Service 05 Date: _____

Engineer Name: _____

License No.: _____

Company: _____

Telephone No.: _____

Stove Inspected: Chimney Swept:

Items Replaced: _____

Service 06 Date: _____

Engineer Name: _____

License No.: _____

Company: _____

Telephone No.: _____

Stove Inspected: Chimney Swept:

Items Replaced: _____

Service 07 Date: _____

Engineer Name: _____

License No.: _____

Company: _____

Telephone No.: _____

Stove Inspected: Chimney Swept:

Items Replaced: _____

Service 08 Date: _____

Engineer Name: _____

License No.: _____

Company: _____

Telephone No.: _____

Stove Inspected: Chimney Swept:

Items Replaced: _____