



UNITED STATES STOVE COMPANY

227 Industrial Park Road • P.O. Box 151 • South Pittsburg, TN 37380 • (423) 837-2100

Natural Gas Model

A9843N

C9843N

G9843N

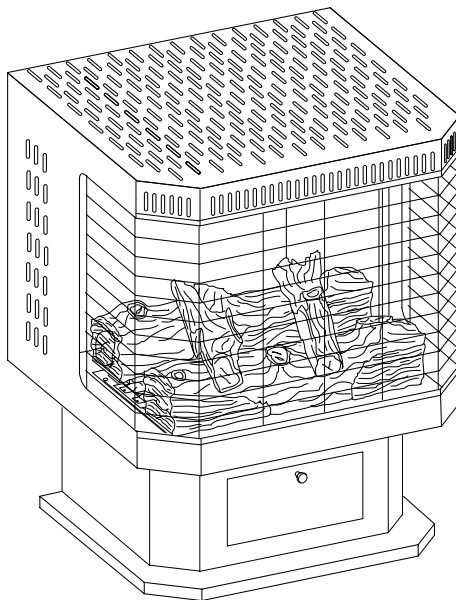

Propane (LPG) Model

A9843L

C9843L

G9843L



VENT-FREE PEDESTAL GAS HEATER INSTALLATION AND OPERATION INSTRUCTIONS

This is an unvented gas-fired heater. It uses air (oxygen) from the room in which it is installed. Provisions for adequate combustion and ventilation air must be provided. Refer to "Adequate Combustion And Ventilation Air" on page 6 of this manual.

THIS APPLIANCE MAY BE INSTALLED IN AN AFTERMARKET* MANUFACTURED (MOBILE) HOME, WHERE NOT PROHIBITED BY STATE OR LOCAL CODES.

***Aftermarket: Completion of sale, not for purpose of resale, from the manufacturer.**

THIS APPLIANCE IS ONLY FOR USE WITH THE TYPE OF GAS INDICATED ON THE RATING PLATE. THIS APPLIANCE IS NOT CONVERTIBLE FOR USE WITH OTHER GASES.

WARNINGS

WARNING: If the information in this manual is not followed exactly, a fire or explosion may result causing property damage, personal injury or loss of life.

- Do not store or use gasoline or other flammable vapors and liquids in the vicinity of this or any other appliance.
- WHAT TO DO IF YOU SMELL GAS
 - Do not try to light any appliance.
 - Do not touch any electrical switch; do not use any phone in your building.
 - Immediately call your gas supplier from a neighbor's phone. Follow the gas supplier's instructions.
 - If you cannot reach your gas supplier, call the fire department.
- Installation and service must be performed by a qualified installer, service agency or the gas supplier.

WARNING: Do not use a blower insert, heat exchanger insert or other accessory not approved for use with this heater.

TABLE OF CONTENTS

IMPORTANT SAFETY INFORMATION	3-4
PRODUCT FEATURES.....	4
SPECIFICATIONS	5
CONTENTS	5
ITEMS REQUIRED FOR INSTALLATION.....	6
INSTALLATION	7
GAS CONNECTION	8-9
GAS PRESSURE CHECK.....	9
LOG ASSEMBLY	10
OPERATING INSTRUCTIONS.....	11-13
CLEANING / SERVICING	13-14
FLAME APPEARANCE	14
PARTS LIST FOR HEATER ASSEMBLY.....	15-16
PARTS LIST FOR BURNER & LOG ASSEMBLY.....	17-18
TROUBLE SHOOTING.....	19-20
OPTIONAL EQUIPMENT.....	21
NOTE.....	22
LIMITED WARRANTY POLICY	23

NOTICE

Installation and repair must be done by a qualified service person. The appliance should be inspected before use and at least annually by a professional service person. More frequent cleaning may be required due to excessive lint from carpeting, bedding material, etc. It is imperative that control compartments, burners and circulating air passageways of the appliance be kept clean.

IMPORTANT SAFETY INFORMATION

INSTALLER: Please leave these instructions with the owner.

OWNER: Please retain these instructions for future reference.

IMPORTANT: Read these instructions carefully before installing or trying to operate this heater.

WARNING

WARNING: Any change to this heater or its controls can be dangerous. Improper installation or use of the heater can cause serious injury or death from fire, burns, explosion or carbon monoxide poisoning.

1. **CARBON MONOXIDE POISONING:** Early signs of carbon monoxide poisoning are similar to the flu with headaches, dizziness and/or nausea. If you have these signs, obtain fresh air immediately. Have the heater serviced as it may not be operating properly.
2. The installation must conform with local codes or, in the absence of local codes, with the National Fuel Gas Code, ANSI Z223.1.
3. The 9843N/9843L vent-free gas heater system cannot be installed in a bedroom.
4. Do not install the heaters in a bathroom.
5. **WARNING:** Improper installation, adjustment, alteration, service or maintenance can cause injury or property damage. Refer to this owner's manual. Installation and service must be performed by a qualified installer; service agency or the gas supplier.
6. To prevent malfunction and/or sooting, an unvented gas heater should be cleaned at least annually by a professional service person. More frequent cleaning may be required due to excessive lint from carpeting, etc. It is imperative that control compartments, burners and circulating air passageways be kept clean.
7. Correct placement of the ceramic fiber logs is necessary to avoid problems with sooting. Sooting can settle on surfaces outside the heater and cause discoloration. See the appropriate sections of this manual for instructions.
8. **WARNING:** Do not allow fans to blow directly into the fireplace. Avoid any drafts that alter burner flame patterns. Do not place a blower inside burn area of firebox. Ceiling fans may create drafts that alter burner flame patterns. Sooting and improper burning will occur.
9. This is an vent-free gas-fired heater. It uses air (oxygen) from the room in which it is installed. Provisions for adequate combustion and ventilation air must be provided. Refer to installation guidelines.
10. Children and adults should be alerted to the hazard of high surface temperature and should stay away to avoid burns or clothing ignition.
11. Young children should be carefully supervised when they are in the same room with the appliance.

IMPORTANT SAFETY INFORMATION

12. Do not place clothing or other flammable material near the appliance.
13. Keep appliance area clear and free from combustible materials, gasoline and other flammable vapors and liquids.
14. Any safety screen or guard removed for servicing, must be replaced prior to operating the heater.
15. This vent-free gas heater is intended to be smokeless. If logs appear to smoke, turn off the heater and call a qualified service person. Initial burn off may cause slight smoke and odor during the first four hours of operation.
16. Input ratings are shown in BTU per hour and are for elevations up to 2,000 feet. For elevations above 2,000 feet, input ratings should be reduced 4 percent for each 1,000 feet above sea level. Refer to the National Fuel Gas Code.
17. The heater and its individual shut off valve must be disconnected from the gas supply piping system during any pressure testing of that system at test pressures in excess of 1/2 psig (3.5 kPa).
18. The heater must be isolated from the gas supply piping system by closing its individual manual shutoff valve during any pressure testing of the gas supply piping system at test pressures equal to or less than 1/2 psig (3.5 kPa).
19. Do not use this room heater if any part has been under water. Immediately call a qualified service technician to inspect the room heater and to replace any part of the control system and any gas control which has been under water.

PRODUCT FEATURES

Features:

- Heating Efficiency - 99.9%
- Wide BTU Range: 10,000 - 39,900.
- Safe Operation - Oxygen Depletion Sensor (ODS).
- No Electricity Required.
- Fibre Ceramic Logs.
- Push-Button Piezo Ignitor.
- Clean Operation.
- Wide Bay Front.
- Easy Operation.
- Heats up to 1,200 square feet.

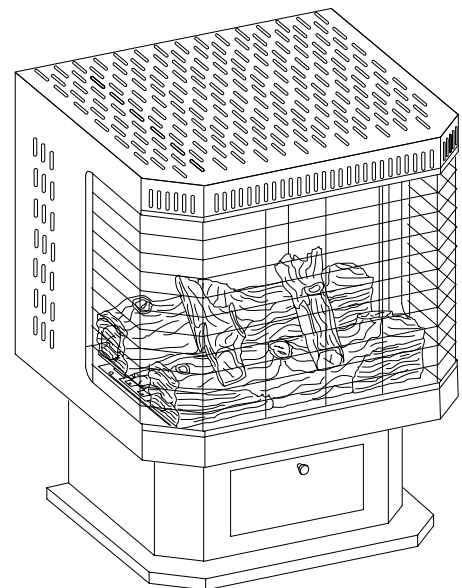

FIGURE 1. 9843 Vent-Free Pedestal Gas Heater.

SPECIFICATIONS

Natural Gas

Manifold Pressure Setting 4" w.c.

Gas Inlet Pressure Maximum 10-1/2" w.c.
 Minimum 5" w.c.

Model Number	Type	Gas Rate		Number of Burners
		Max BTU/Hr	Min BTU/Hr	
9843N	Manual	39,900	10,000	2

Propane/LPG

Note: An external regulator is required to reduce supply pressure to a maximum of 13" w.c.

Manifold Pressure Setting 10" w.c.

Gas Inlet Pressure Maximum 13" w.c.
 Minimum 11" w.c.

Model Number	Type	Gas Rate		Number of Burners
		Max BTU/Hr	Min BTU/Hr	
9843L	Manual	39,900	10,000	2

Controls - Main control has 4 positions:

1. **OFF** - All gas to the gas logs is shut off at the control
2. **IGN** - Piezo ignitor allows ignition of the pilot without the use of matches or batteries
3. **PILOT** - Valve position to light / maintain a standing pilot
4. **ON** - Gas flow to complete system, front burner ignition

Front Burner Control Knob - Infinite control, rotate clockwise to minimum rate and counter clockwise for maximum rate.

Rear Burner Control Knob - Has 3 positions:

1. **OFF** - Gas to rear burner is shutoff at control
2. **ON/MAX** - Maximum gas flow to rear burner
3. **MIN** - Minimum gas flow rate to rear burner

CONTENTS

9843L and 9843N Unvented Gas Heaters

1. Packet containing Homeowners/Installation instructions.
2. Log box containing four (4) fiber ceramic logs, refer to installation instructions.
3. Unvented gas heater.

CHECK THAT ALL LISTED PARTS HAVE BEEN RECEIVED

CAUTION

GLOVES ARE RECOMMENDED WHEN HANDLING CERAMIC FIBER LOGS TO PREVENT SKIN IRRITATION FROM LOOSE FIBERS. LOGS ARE FRAGILE, HANDLE WITH CARE.

Carefully inspect the contents for shipping damage and immediately inform your dealer if any damage is found.

ITEMS REQUIRED FOR INSTALLATION

ITEMS REQUIRED FOR INSTALLATION

Ensure that the following items are available before proceeding with installation:

- External regulator (for propane/LPG only)
- Piping which complies with local codes
- Pipe sealant approved for use with propane/LPG (resistant to sulfur compounds)
- Manual shutoff valve
- Sediment trap
- Pipe wrench

CODES

Adhere to all local codes or in their absence, the latest edition of THE NATIONAL FUEL GAS CODE ANSI Z223.1 or NFPA54 which can be obtained from:

American National Standards Institute, Inc.

1430 Broadway
New York, NY 10018

or

National Fire Protection Association, Inc.

Batterymarch Park
Quincy, MA 02269

WARNING

Due to high temperatures, do not install the heater:

- **Where curtains, furniture, clothing or other flammable objects are less than 42" from the front of the heater.**
- **In high traffic areas.**
- **In windy or drafty areas.**

DO NOT PLACE CLOTHING OR OTHER FLAMMABLE MATERIAL ON OR NEAR THE APPLIANCE.

ADEQUATE COMBUSTION AND VENTILATION AIR

This heater shall not be installed in a confined space or unusually tight construction unless provisions are provided for adequate combustion and ventilation air.

Unusually tight construction is defined as construction where:

- (a) Walls and ceilings exposed to the outside atmosphere have a continuous water vapor retarder with a rating of 1 perm (6×10^{11} kg per pa-sec- m^2) or less with openings gasketed or sealed, and
- (b) Weather stripping has been added on openable windows and doors, and
- (c) Caulking or sealants are applied to areas such as joints around window and door frames, between sole plates and floors, between wall-ceiling joints, between wall panels, at penetrations for plumbing, electrical, and gas lines, and at other openings.

The National Fuel Gas Code defines a confined space as a space whose volume is less than 50 cubic feet per 1,000 BTU per hour ($4.8m^3$ per kw) of the aggregate input rating of all appliances installed in that space and an unconfined space is defined as a space whose volume is not less than 50 cubic feet per 1,000 BTU per hour ($4.8m^3$ per kw) of the aggregate input rating of all appliances installed in that space. Rooms communicating directly with the space in which the appliances are installed, through openings not furnished with doors, are considered a part of the unconfined space.

INSTALLATION

The following formula can be used to determine the maximum heater rating per the definition of unconfined space:

$$\frac{\text{BTU/HR} = (L1+L2) \text{ Ft} \times (W) \text{ Ft} \times (H) \text{ Ft} \times 1000}{50}$$

Consider two connecting rooms with an open area between, with the following dimensions: (See Fig. 2, Example)

$$\frac{L1=15-1/2 \text{ Ft.}, L2=12 \text{ Ft.}, W=12 \text{ ft.}, H=8 \text{ Ft}}{50} \\ =52800 \text{ BTU/HR}$$

If there were a door between the two rooms the calculation would be based only on the room with the heater.

$$\frac{\text{BTU/HR}=(15-1/2) \times (12) \times (8) \times 1000}{50} \\ =29760 \text{ BTU/HR}$$

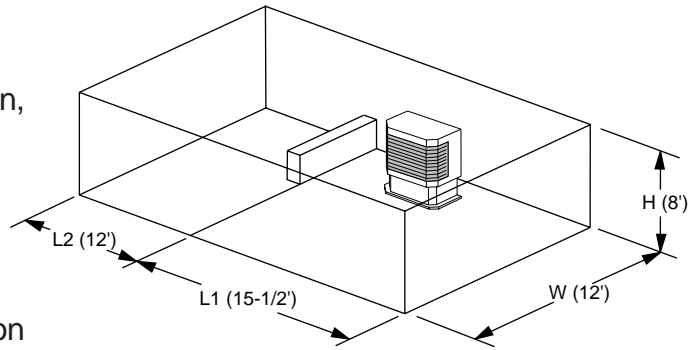

FIGURE 2.

WARNING

When installing the appliance directly on carpeting, tile or other combustible material, other than wood flooring, the appliance must be installed on a metal or wood panel extending the full width and depth of the appliance.

WARNING

If the area in which the heater may be operated is smaller than that defined as an unconfined space or if the building is of unusually tight construction, provide adequate combustion and ventilation air by one of the methods described in the National Fuel Gas Code, ANSI Z223.1, Section 5.3, or applicable local codes.

WARNING

Ensure the minimum clearances shown in FIGURE 4 are maintained for accessibility for purposes of servicing and proper operation. Left and right clearances are determined when facing the front of the heater.

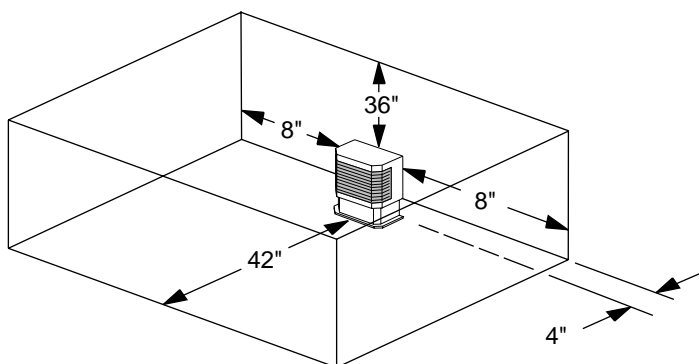

FIGURE 3. Minimum Clearances

Maintain these clearances to ensure adequate space around air opening for proper operation.

Minimum clearances to combustibles:

Top of heater.....	36"
Sides of heater.....	8"
Front of heater.....	42"
Rear of heater.....	4"

GAS CONNECTION

NOTICE

A qualified gas appliance installer must connect the fireplace to the gas supply. Consult all local codes.

CAUTION

Use new black iron or steel pipe only. Internally tinned copper tubing can be used in some areas when permitted by local codes. Only use pipe of 1/2" or greater diameter to allow full gas volume to heater. Excessive pressure loss will occur if the pipe is too small.

A manual shutoff valve, union and plugged 1/8" NPT pressure tapping point must be installed upstream of the heater (FIGURE 4).

A sediment trap must be installed upstream of the heater to prevent moisture and contaminants from passing through the pipe to the heater controls and burners. Failure to do so could prevent the heater from operating reliably (FIGURE 4).

IMPORTANT: Loosen the pipe adapter on the flex tube before installing to the system piping.

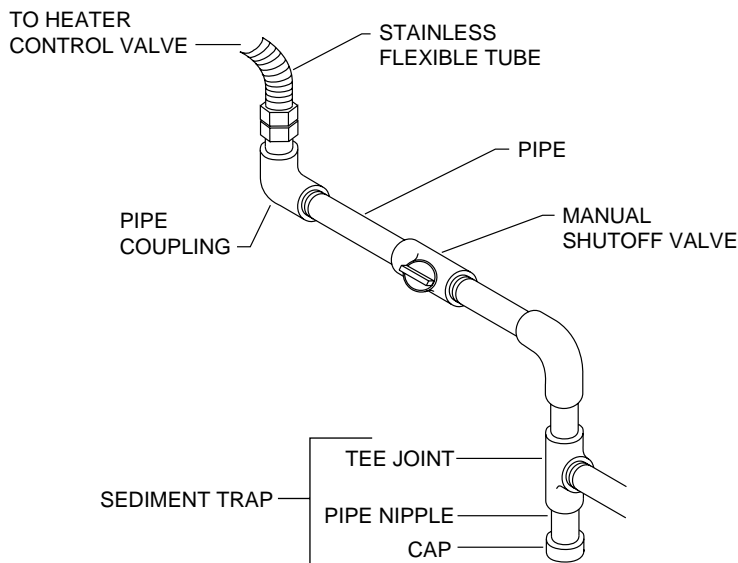

FIGURE 4. Gas Connection

CHECK GAS TYPE: The gas supply must be the same as stated on heater's rating plate. If the gas supply is different, DO NOT INSTALL the heater. Contact your dealer for the correct model.

WARNING

Connecting directly to an unregulated propane/LPG tank can cause an explosion.

GAS CONNECTION

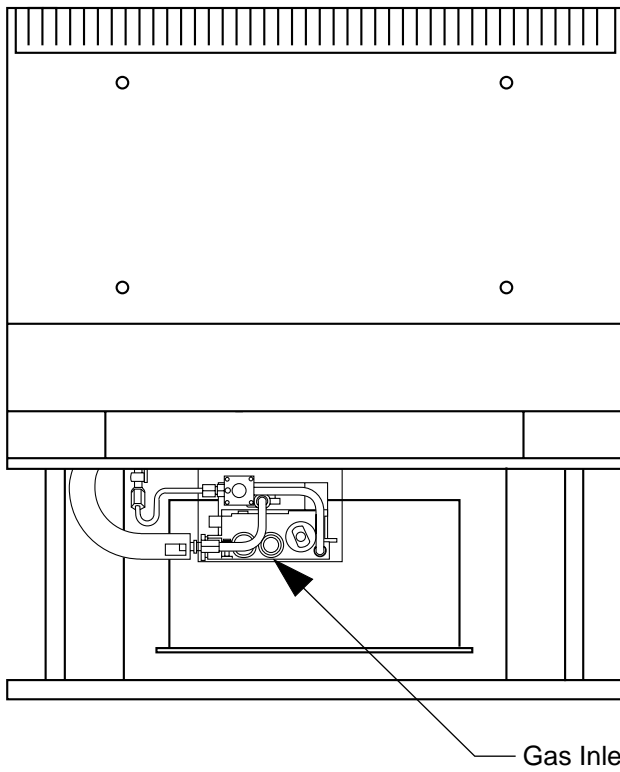

The gas inlet connection is 3/8" NPT, made at the rear of the main control through the area at the rear of the pedestal.

Test all gas joints from the gas meter to the heater for leaks using soap and water solution after completing connection. **DO NOT USE AN OPEN FLAME.**

FIGURE 5. Rear View of 9843 Vent-Free Gas Heater

GAS PRESSURE CHECK

The heater regulator controls the burner pressure which should be checked at the pressure test point located on the right side of the main control and is accessible from the side of the gas log assembly (see FIGURE 6).

The pressure should be checked with the heater burning and the control set to high (HI).

The pressure regulator is preset and locked to avoid tampering. If the pressure is not as specified in Product Specifications (Page 5), contact your dealer and replace the regulator.

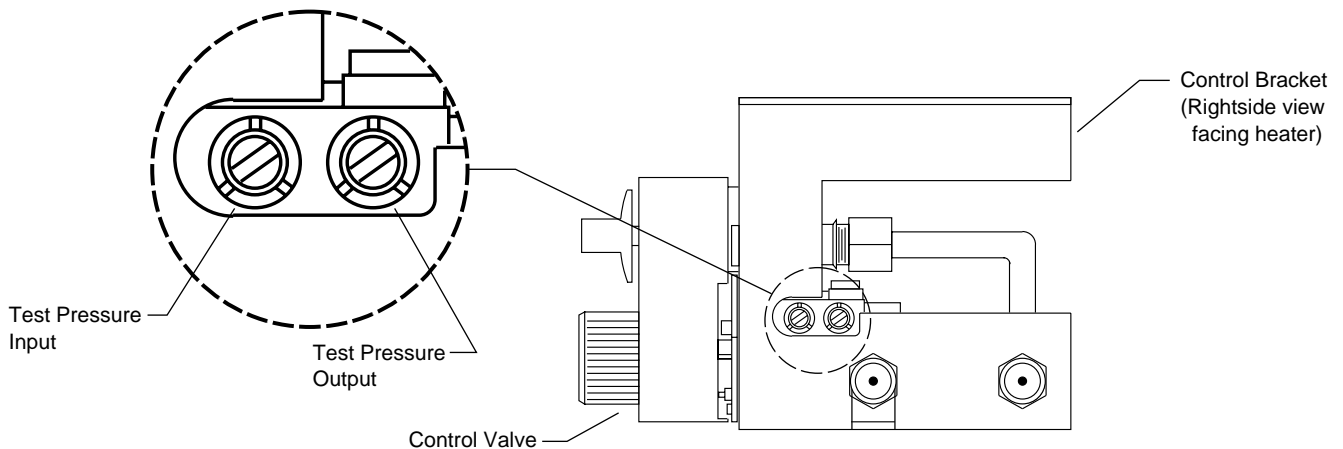
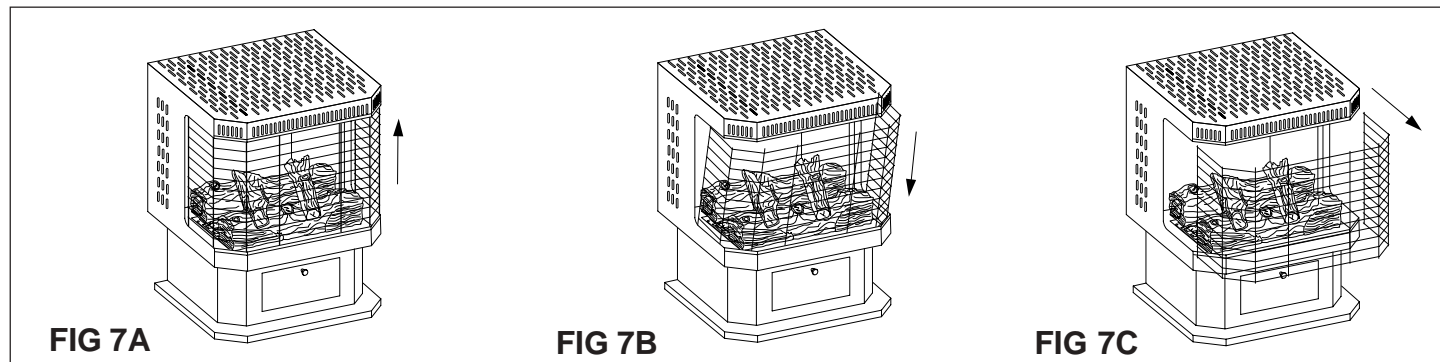

FIGURE 6. Pressure Test Point Location

REMOVING FRONT SCREEN

1) Lift the front screen slightly up (Fig. 7A) and then tilt the bottom of the screen inward and downward (Fig. 7B). 2) Lean the top of the screen toward you slightly (Fig. 7B) and then proceed to carefully bring the screen straight back (Fig. 7C). NOTE: To reinstall the front screen, reverse steps 1 & 2.



LOG ASSEMBLY

LOG POSITIONING

This unit is supplied with a set of four ceramic fiber logs. Do not handle these logs with your bare hands! Always wear gloves to prevent skin irritation from ceramic fibers. After handling logs, wash your hands gently with soap and water to remove any traces of fibers.

PROPER INSTALLATION SEQUENCE:

1. Install the rear log (#2) on the rear set of locators. Visually check to verify the log is securely placed on the locators.
2. Install the front log (#1) on the front locators. Visually check to verify the log is securely placed on the locators.
3. Install the left and right cross twigs as illustrated, on the locator pins provided in the front and rear logs. Holes provided in the bottom of the cross twigs should allow them to seat completely over these pins.

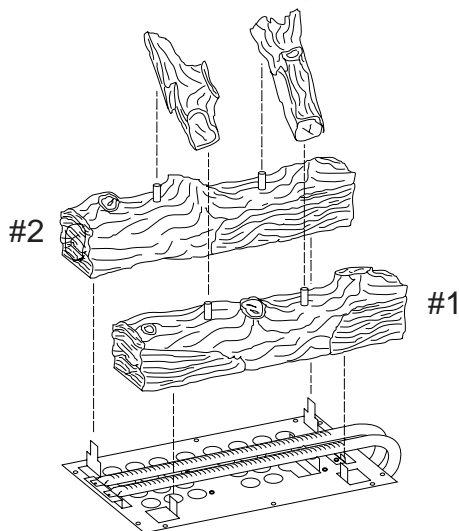

WARNING: Failure to position the parts in accordance with these diagrams or failure to use only parts specifically approved with this heater may result in property damage or personal injury.

FIGURE 8. Log Set Assembly

WARNING

The positioning of the logs is critical to the safe and clean operation of this heater. Sooting and other problems may result if the logs are not properly and firmly situated in the appliance. Never add additional logs or embellishments such as pine cones, vermiculite or rock wool to the heater.

FRONT SCREEN

The front screen must be in place at all times when the appliance is operating. Do not obstruct the screened openings of the heater.

OPERATING INSTRUCTIONS

Avoid any drafts that alter the burner flame patterns. Do not allow fans to blow directly into the heater. Do not place a blower inside burn area of firebox. Ceiling fans may create drafts that alter burner flame patterns. Sooting and improper burning will occur.

This vent-free gas heater is intended to be smokeless. If logs appear to smoke, turn off the heater and call a qualified service person. Initial burn off may cause slight smoke and odor during the first four hours of operation.

FOR YOUR SAFETY READ BEFORE LIGHTING

WARNING

WARNING: If you do not follow these instructions exactly, a fire or explosion may result causing property damage, personal injury or loss of life.

- A. This appliance is equipped with an ignition device (Piezo) which automatically lights the pilot. If Piezo fails, then light the pilot using matches. Refer to match lighting instructions (page 13). When lighting the pilot, follow these instructions exactly.
- B. BEFORE LIGHTING smell all around the appliance area for gas. Be sure to smell next to the floor because some gas is heavier than air and will settle on the floor.

WHAT TO DO IF YOU SMELL GAS

- Do not attempt to light any appliance.
 - Do not touch any electric switch; do not use any phone in your building.
 - Immediately call your gas supplier from a neighbor's phone. Follow the gas supplier's instructions.
 - If you cannot reach your gas supplier, call the fire department.
- C. Use only your hand to push in or turn the gas control knob. Never use tools. If the knob will not push in or turn by hand, don't try to repair it, call a qualified service technician. Force or attempted repair may result in a fire or explosion.
 - D. Do not use this appliance if any part has been under water. Immediately call a qualified service technician to inspect the appliance and to replace any part of the control system and any gas control which has been under water.

FOR YOUR SAFETY

Do not store or use gasoline or other flammable vapors and liquids in the vicinity of this or any other appliance.

OPERATING INSTRUCTIONS



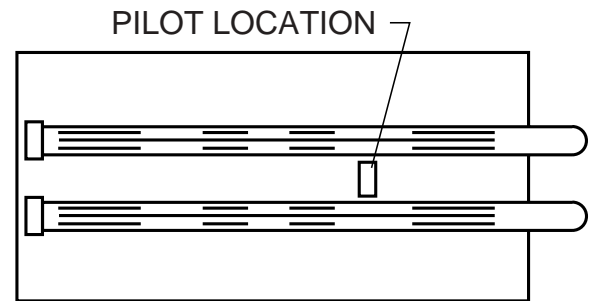

LIGHTING INSTRUCTIONS

1. STOP! Read the safety information on the previous page.
2. Turn off all electrical power and open the access door.
3. Turn off the rear burner and set the front burner to low.
4. Push in gas control (knob 1) slightly and turn clockwise  to "OFF".

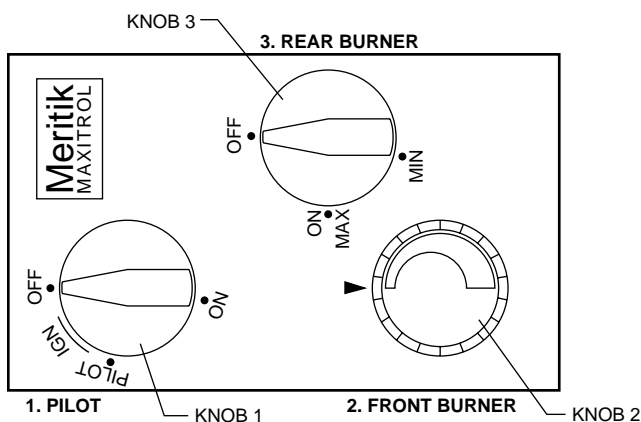

TOP VIEW OF BURNER ASSEMBLY





6. Push in the control (knob 1) all the way and rotate counter-clockwise  to "PILOT". The piezo ignitor will light the pilot as the knob passes "IGN" traveling to the "PILOT". Continue to hold the control (knob 1) in for about ten (10) seconds after the pilot is lit. Release knob and it should pop back up. Pilot should remain lit. If it goes out, repeat steps 4 through 6. If the control (knob 1) does not pop up when released, stop and immediately call your service technician or gas supplier. If the pilot will not stay lit after several tries, turn the gas control (knob 1) to "OFF" and call your service technician or your gas supplier.
7. Turn gas control (knob 1) counter-clockwise  to "ON".
8. Set the front burner (knob 2) to the desired setting rotating counter-clockwise  to MAX. and clockwise  to MIN.
9. Set the rear burner (knob 3) to the desired setting rotating counter-clockwise  to MAX./ ON or MIN.
10. Close access door and turn on electrical power.

NOTE: Knob cannot be turned from "PILOT" to "OFF" unless knob is pushed in slightly. Do not force.

5. Wait five (5) minutes to clear out any gas. Then smell for gas, including near the floor. If you smell gas, STOP! Follow "B" in the safety information on the previous page. If you don't smell gas, go on to the next step.

TURN OFF GAS TO APPLIANCE

1. Open access door.
2. Set front burner to Min. and turn off the rear burner by depressing knob and rotating clockwise  until stop.
3. Unplug all electric power (optional blower) if service is to be performed.
4. Push in gas control knob slightly and turn clockwise  to "OFF". Do not force.
5. Close access door.

OPERATING INSTRUCTIONS

WARNING

Wait 30 seconds before readjusting the heater when the control has been turned down to a lower setting.

MATCH LIGHTING INSTRUCTIONS

If the pilot will not light using the piezo ignitor, you can light the pilot with a match. First, locate the pilot. The pilot is located between the two burner tubes on the right end (facing the unit), inside the firebox. To light pilot with a match, move the gas control (knob 1, pg. 12) to the pilot position and hold down. Light match and place near pilot. Once pilot is lit, continue to hold the knob for about ten seconds. Then follow steps 7 thru 10 on page 12.

CHECKING FLAME APPEARANCE

Flames from the pilot, front and rear burner should be visually checked when the heater is installed. In addition a periodic visual check of the flames should be made.

PILOT FLAME

The pilot flame should always be present when the heater is in operation and should just touch the top of the thermocouple tip (FIGURE 9).

If the pilot flame does not touch the thermocouple, then the main burner is unlikely to function reliably (FIGURE 10).

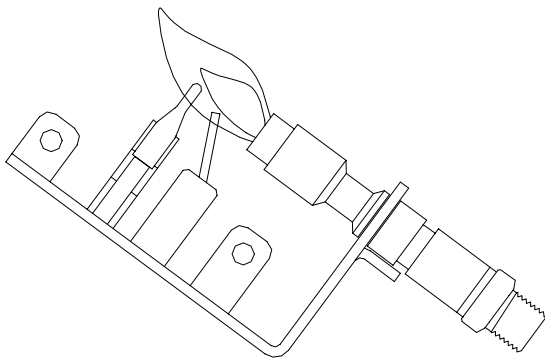

FIGURE 9. Pilot Flame

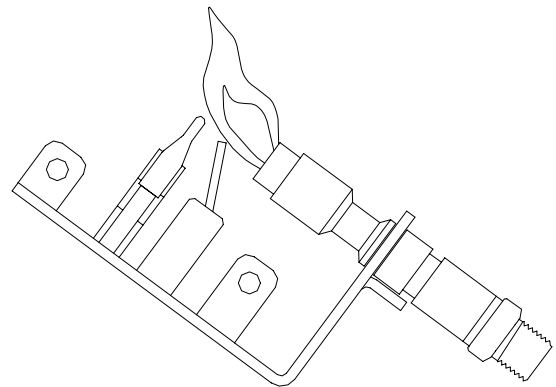

FIGURE 10. Incorrect Shape of Pilot Flame

CLEANING / SERVICING

Annual inspection and cleaning by your dealer or qualified service technician is recommended to prevent malfunction and/or sooting.

WARNING

Turn off heater and allow to cool before cleaning.

Remove front screen, (see page 6). Carefully lift screen from locating stubs and set aside during cleaning. Refer to instructions on page 6 for installation of screen. **Do not operate the unit with the screen removed.**

Remove logs, handling carefully by holding gently at each end. Gloves are recommended to prevent skin irritation from ceramic. If the skin becomes irritated, wash gently with soap and water. Refer to manual for correct log placement.

CLEANING / SERVICING

Periodic Cleaning

- Do not use cleaning fluid to clean logs or any part of heater.
- Logs - Brush with soft bristle brush or vacuum with brush attachment.
- Vacuum loose particles and dust from the front and rear burner, control, and piezo.
- Inspect burner's and air intake hole. Remove lint or particles with vacuum.
- External case should be dusted and wiped with a wet soapy cloth.

Annual Cleaning/Inspection

- Inspect and clean burner air intake holes.
- Inspect and clean all burner ports.
- Inspect ODS pilot for operation and accumulation of lint at air intake holes.
- Verify flame pattern and log placement for proper operation.

FLAME APPEARANCE

- Verify smooth and responsive ignition of main burner and rear burner.

In normal operation at full rate after 15 minutes the following flame appearance should be observed.

FLAMES

The flames behind log #1, and in front of log #2, should be yellow with a blue base. The flames should

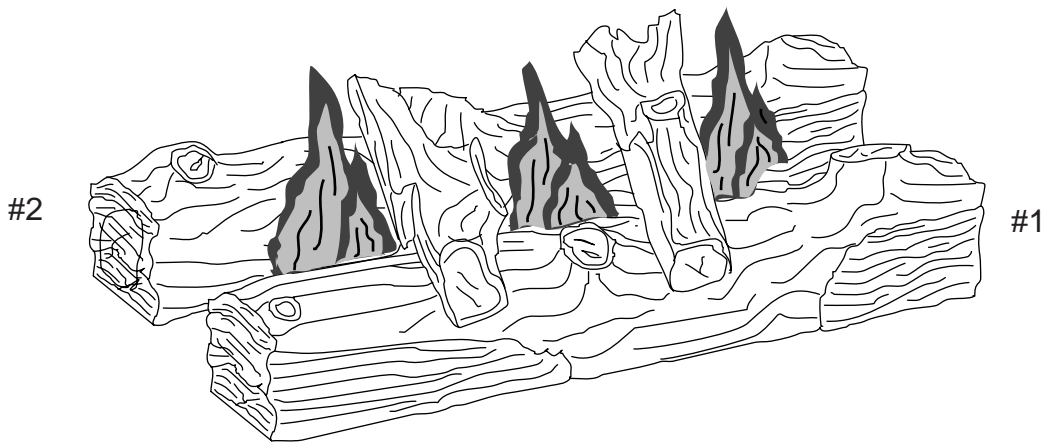

not be impinging on the small cross twigs. (See Below, Figure 11)

FIGURE 11. Flames - Natural Gas and LP Gas

HEATER ASSEMBLY REPLACEMENT PARTS

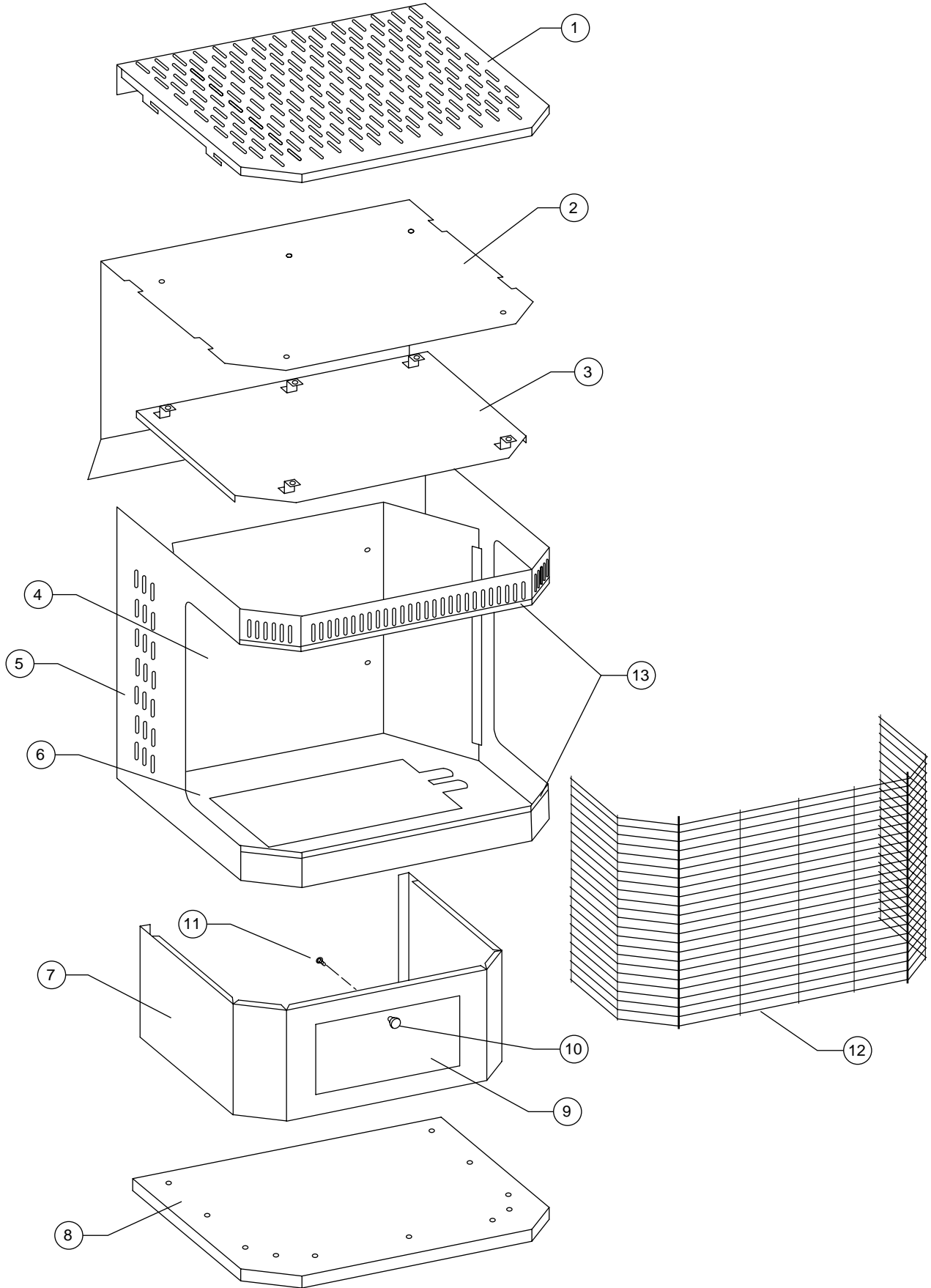

PARTS LIST FOR HEATER ASSEMBLY

KEY	PART #	DESCRIPTION	QTY.
1	69138	CABINET TOP ASSY.	1
2	69137	FIREBOX BACK WELDMENT	1
3	24606	FIREBOX TOP	1
4	24605	INSIDE BACK	1
5	69136	FIREBOX WELDMENT	1
6	24601	FIREBOX BOTTOM	1
7	69135	PEDESTAL WELDMENT	1
8	24599	PEDESTAL BASE	1
9	24457	CONTROL DOOR	1
10	89336	BRASS KNOB	1
11	83115	10-32 x 1/2 MACHINE SCREW	1
12	24614	FRONT SCREEN (PAINTED)	1
13	89869	BRASS TRIM	2
N/S	89824	MAGNETIC LATCH	1
N/S	83343	#10 x 1/2 HX HD SCREWS	54

N/S = NOT SHOWN

IMPORTANT NOTICE: WHEN ORDERING CABINET PARTS, PLACE THE APPROPRIATE CODE AFTER THE PART NUMBER THAT CORRESPONDS TO THE COLOR OF YOUR UNIT.

ALMOND = A
 CHARCOAL GRAY = C
 GREEN = G

BURNER & LOG ASSEMBLY

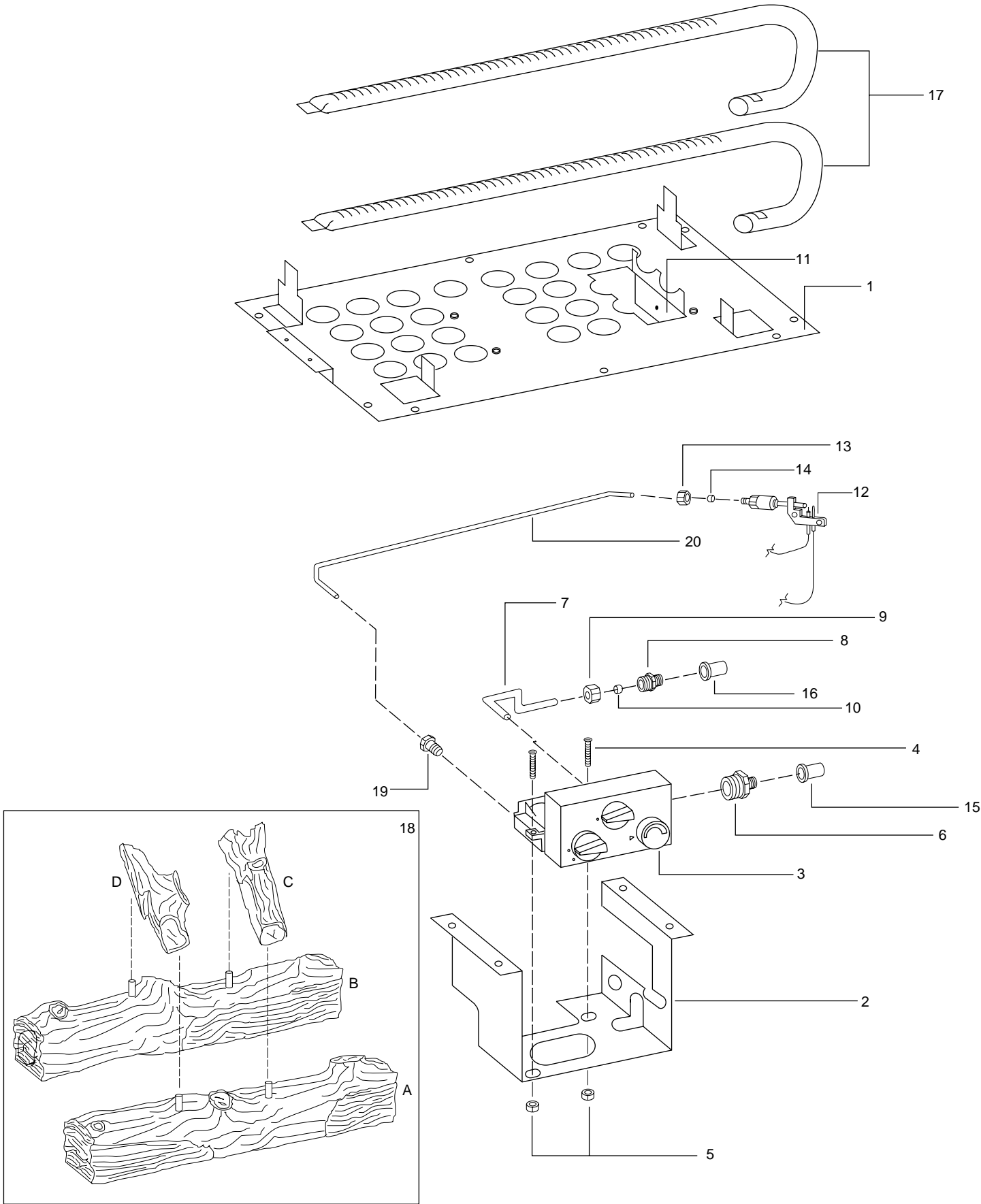

PARTS LIST FOR GAS LOG ASSEMBLY

KEY	PART #	DESCRIPTION	QTY.
1	24610	BURNER PLATE	1
2	24611	CONTROL BRACKET	1
3	81193	CONTROL VALVE (NATURAL)	1
	81194	CONTROL VALVE (L.P.)	1
4	83251	10-24 x 1 SL ROD	2
5	83244	10-24 KEP NUT	2
N/S	83343	#10 X 1/2 HX HD SCREW	10
6	89831	BURNER/CONTROL FITTING	1
7	89834	1/4" TUBE, BURNER/REGULATOR	1
8	89838	1/4 CC X 3/8-27 FITTING	1
9	89839	1/4 COMPRESSION NUT	1
10	89840	1/4 COMPRESSION SLEEVE	1
11	24612	PILOT BRACKET	1
12	89872	"O.P. AMERICA" NAT. PILOT	1
	89873	"O.P. AMERICA" L.P. PILOT	1
N/S	83437	10-3/4 HX HD SCREW (TO MOUNT PILOT)	2
13	89841	3/16 COMPRESSION NUT	1
14	89842	3/16 COMPRESSION SLEEVE	1
15	89829	#47 NATURAL BURNER ORIFICE (FRONT)	1
	89836	#55 L.P. BURNER ORIFICE (FRONT)	1
16	89830	#48 NATURAL BURNER ORIFICE (REAR)	1
	89836	#55 L.P. BURNER ORIFICE (REAR)	1
17	24613	BURNER (PAINTED)	2
18	89874	LOG SET (CONSISTS OF 4 PIECES)	1
a	89874-1	FRONT LOG	-
b	89874-2	REAR LOG	-
c	89874-3	RIGHT TWIG	-
d	89874-4	LEFT TWIG	-
19	89856	3/16" LOXIT FITTING	1
N/S	86318	16GA WIRE LINK	1FT.
20	89855	PILOT TUBE	1

N/S = NOT SHOWN

TROUBLESHOOTING

WARNING

Turn off and let cool before servicing. Only a qualified service person should service and repair heater.

NOTE: All troubleshooting items are listed in order of operation.

OBSERVED PROBLEM	POSSIBLE CAUSE	REMEDY
When ignitor button is pressed, there is no spark at ODS/Pilot.	<ul style="list-style-type: none"> • Ignitor electrode positioned wrong • Ignitor electrode is broken • Ignitor electrode not connected to ignitor cable. • Ignitor cable pinched or wet keep ignitor cable dry. • Broken ignitor cable • Bad piezo ignitor 	<ul style="list-style-type: none"> • Replace ignitor. • Replace ignitor. • Reconnect ignitor cable. • Free ignitor cable if pinched by any metal or tubing. • Replace ignitor cable. • Replace piezo ignitor.
Appliance produces unwanted odors.	<ul style="list-style-type: none"> • Appliance burning vapors from paint, hair spray, glues, etc. • Gas leak. 	<ul style="list-style-type: none"> • Ventilate room. Stop using odor-causing products while heater is running. • Locate and correct all leaks.
Appliance shuts off in use.	<ul style="list-style-type: none"> • Not enough fresh air is available for ODS/Pilot to operate. • Low line pressure. • ODS/Pilot is partially clogged. 	<ul style="list-style-type: none"> • Open window and/or door ventilation • Contact local gas company. • Clean ODS/Pilot.
Gas odor even when control knob is in OFF position.	<ul style="list-style-type: none"> • Gas leak. • Control valve defective. 	<ul style="list-style-type: none"> • Locate and correct all leaks. • Replace control valve.
When ignitor button is pressed, there is spark at ODS/Pilot, but no ignition.	<ul style="list-style-type: none"> • Gas supply turned off or manual shutoff valve closed. • Control knob not in PILOT position. • Control knob not pressed in while in Pilot position • Air in gas lines when installed. • ODS/Pilot is clogged. • Gas regulator setting is not correct. 	<ul style="list-style-type: none"> • Turn on gas supply or open manual shutoff valve. • Turn control knob while in PILOT position. • Press in control knob while in PILOT position. • Continue holding down control knob. Repeat igniting operation until air is removed • Replace ODS/pilot assembly or get is serviced
ODS/Pilot lights, but flame goes out when control knob is released.	<ul style="list-style-type: none"> • Control knob not fully pressed in. • Control knob not pressed in long enough. • Manual shutoff valve not fully open. 	<ul style="list-style-type: none"> • Replace gas regulator. • Press in control knob fully. • After ODS/pilot lights, keep control knob pressed in 30 seconds.

• Fully open manual shutoff valve.

TROUBLESHOOTING, CONTINUED...

OBSERVED PROBLEM	POSSIBLE CAUSE	REMEDY
<p>ODS/Pilot lights, but flame goes out When control knob is released. (continued from page 17)</p>	<ul style="list-style-type: none"> • Thermocouple connection loose at control valve. • Pilot flame not touching thermocouple, which allows thermocouple to cool, causing pilot flame to go out. This problem could be caused by either low gas pressure, or a dirty or partially clogged ODS/pilot. • Thermocouple damaged. • Control valve damaged. 	<ul style="list-style-type: none"> • Hand tighten until snug, then tighten 1/4 turn more. • Contact local gas company. • Replace thermocouple. • Replace control valve.
<p>One or both burner do not light after ODS/pilot is lit.</p>	<ul style="list-style-type: none"> • Burner orifice is clogged. • Burner orifice diameter is too small. • Inlet gas pressure is too low. 	<ul style="list-style-type: none"> • Clean burner or replace burner orifice. • Replace burner orifice. • Contact qualified service person.
<p>Burner backfires during combustion.</p>	<ul style="list-style-type: none"> • Manifold pressure is too low. • Burner orifice is clogged. 	<ul style="list-style-type: none"> • Contact local gas company. • Clean burner or replace burner orifice.
<p>Slight smoke or odor during initial operation.</p>	<ul style="list-style-type: none"> • Burner orifice is clogged or damaged. • Burner is damaged. • Gas regulator defective. 	<ul style="list-style-type: none"> • Clean burner or replace burner orifice. • Replace burner. • Replace gas regulator.
<p>Logs appear to smoke after initial operation.</p>	<ul style="list-style-type: none"> • Vapors from paint or curing process of logs. 	<ul style="list-style-type: none"> • Problem will stop after a few hours of operation. Run the heater with the damper open if you have one, or open a window for the first few hours. • Log heater is intended to be smokeless. Turn OFF heater and call qualified service person.
<p>Heater produces a whistling noise when burner is lit.</p>	<ul style="list-style-type: none"> • Turning control knob to HIGH (3) position when burner is cold. • Air in gas line. • Dirty or partially clogged burner orifice. 	<ul style="list-style-type: none"> • Turn control knob to LOW (2) position and let warm up for a minute. • Operate burner until air is removed from line. Have gas line checked by local gas company. • Clean burner or replace burner orifice.
<p>No gas to pilot.</p>	<ul style="list-style-type: none"> • LP-regulator shut down due to inlet pressure too high. 	<ul style="list-style-type: none"> • Verify LP tank regulator is installed and set to 11" to 13" w.c. Replace regulator on heater.

WARNING

If the gas quality is bad, your pilot may not stay lit, the burners may produce soot and the heater may backfire when lit. If the gas quality or pressure is low, contact your local gas supplier immediately.

OPTIONAL F40 BLOWER KIT

THIS OPTIONAL F40 BLOWER KIT IS AVAILABLE WHERE YOU PURCHASED THIS HEATER OR YOU CAN ORDER DIRECT FROM THE FACTORY BY CONTACTING THE PARTS DEPARTMENT AT THE NUMBER AND ADDRESS ON THE BACK PAGE OF THIS MANUAL.

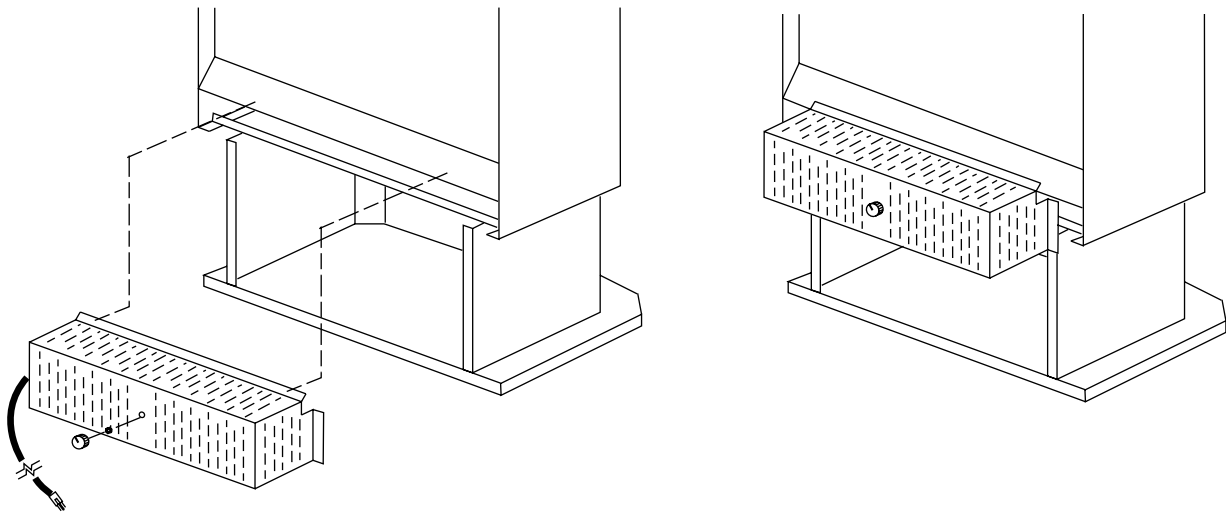

BACK VIEW OF 9843

NOTES

LIMITED WARRANTY POLICY

This vent-free gas heater is warranted for a period of one year, logs for one year, and burners for One Year, from date of purchase against defects in material or workmanship. This warranty covers only the cost of defective parts and applies only to the original consumer purchaser. The replacement of defective parts will be without charge. This warranty does not extend to (1) heater damage by accident, neglect, misuse, abuse, alteration, negligence of others, including the installation thereof by unqualified installers, (2) the costs of removal, reinstallation or transportation of defective parts on the heater, or (3) incidental or consequential damage.

THIS WARRANTY IS EXPRESSLY IN LIEU OF OTHER WARRANTIES, EXPRESS OR IMPLIED, INCLUDING THE WARRANTY OF MERCHANTABILITY OF FITNESS FOR PURPOSE AND OF ALL OTHER OBLIGATIONS OR LIABILITIES, UNITED STATES STOVE COMPANY DOES NOT ASSUME FOR IT, ANY OTHER OBLIGATION OR LIABILITY IN CONNECTION WITH THE SALE OR USE OF THIS HEATER.

The heater (MUST BE INSTALLED BY A QUALIFIED INSTALLER) in accordance with the instructions furnished with the unit. The defective heater should be returned at your expense to the dealer from whom the product was purchased or an authorized service agent. Any products presented for warranty repair must be accompanied by a dated proof of purchase. Since some states do not allow the exclusion on limitation of incidental or consequential damages, or on how long an implied warranty lasts, the above limitations may not apply to you.

OWNERS MANUAL

HOW TO ORDER REPAIR PARTS OR "OPTIONS"

THIS MANUAL WILL HELP YOU TO OBTAIN EFFICIENT, DEPENDABLE SERVICE FROM THE FURNACE, AND ENABLE YOU TO ORDER REPAIR PARTS CORRECTLY.

KEEP IN A SAFE PLACE FOR FUTURE REFERENCE.

WHEN WRITING, ALWAYS GIVE THE FULL MODEL NUMBER WHICH IS ON THE NAMEPLATE ATTACHED INSIDE THE FRONT OF THE HEATER.

WHEN ORDERING REPAIR PARTS OR OPTIONS, ALWAYS GIVE THE FOLLOWING INFORMATION AS SHOWN IN THIS LIST:

1. The **PART NUMBER**
2. The **PART DESCRIPTION**
3. The **MODEL NUMBER:** 9843N 9843L
4. The **SERIAL NUMBER** _____

BEFORE INSTALLING YOUR HEATER, FILL IN THE SERIAL NUMBER IN THE SPACE PROVIDED ABOVE FOR YOUR RECORDS.



UNITED STATES STOVE COMPANY

227 Industrial Park Rd., P.O. Box 151
South Pittsburg, TN 37380
(423) 837-2100