

# OWNERS MANUAL

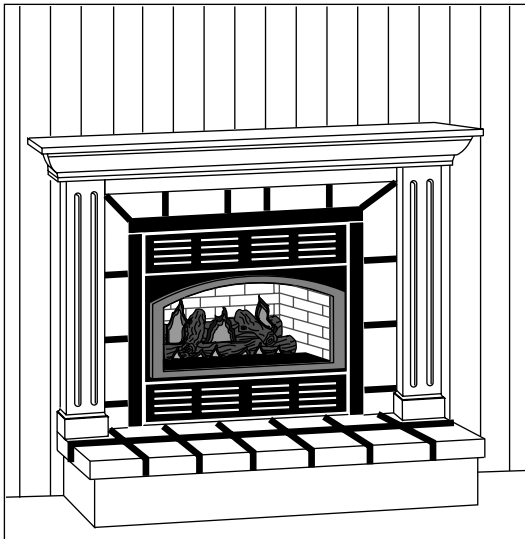

## GRAVITY TYPE DIRECT VENT WALL FURNACE MODEL # 9660

MAY BE INSTALLED IN A MANUFACTURED HOME (MOBILE HOME).



**United States Stove Company**  
227 Industrial Park Road • P.O. Box 151  
South Pittsburg, TN 37380  
(423) 837-2100

**WARNING:** If the information in this manual is not followed exactly, a fire or explosion may result causing property damage, personal injury or loss of life.

- Do not store or use gasoline or other flammable vapors and liquids in the vicinity of this or any other appliance.
- WHAT TO DO IF YOU SMELL GAS
  - Do not try to light any appliance.
  - Do not touch any electrical switch; do not use any phone in your building.
  - Immediately call your gas supplier from a neighbor's phone. Follow the gas supplier's instructions.
  - If you cannot reach your gas supplier, call the fire department.
- Installation and service must be performed by a qualified installer, service agency or the gas supplier.

**Warning:** Improper installation, adjustment, alteration, service or maintenance can cause property damage, personal injury or loss of life. Refer to this manual. Installation and service must be performed by a qualified installer, service agency or the gas supplier.

## TABLE OF CONTENTS

Introduction.....	2
Important Information.....	2
Gas Specifications.....	2
Furnace Dimensions.....	3
Planning your Furnace Installation.....	4-5
Installation Instructions for Optional	
Blower Kit.....	5
Operation and Maintenance.....	6-7
Venting Instructions.....	7-8
Venting Tables.....	9
Pipe Installation.....	10-12
Gas Pressure Requirements.....	13
Millivolt System Check.....	13
Testing Manifold & Inlet Pressure.....	14
LP/Natural Gas Conversion.....	14
Troubleshooting.....	15-16
Lighting Instruction Label.....	17
Repair Parts (Generator Assembly).....	18-19
Repair Parts (Main Assembly).....	20-21
Optional Kits.....	22
Wiring Diagrams.....	23-25
Notes.....	26-27
How To Order Repair Parts.....	28

**WARNING:** Do not operate appliance with the glass door removed, cracked or broken. Replacement of the glass should be done by a licensed or qualified service person.

**CAUTION:** Label all wires prior to disconnection when servicing controls. Wiring errors can cause improper and dangerous operation. Verify proper operation after servicing.

## INTRODUCTION

Thank you for your purchase of the Model 9660 Gravity type vented wall furnace. By following the instructions in this manual you can be assured of an installation that will add both beauty and value to your home, as well as provide safe, efficient supplemental heat.

Your dealer can be a valuable source of information as well as recommending professionals who can assist in installation and maintenance.

**Improper maintenance may void warranty and can cause injury or property damage. Refer to this manual.**

### IMPORTANT INFORMATION

For safe installation and operation of your fireplace, please note the following:

1. This appliance should only be installed by a qualified installer. Installation must conform with local codes, or in the absence of local codes, with the latest edition of the National Fuel Gas Code, ANSI Z 223.1-1992/NFPA 54-1992.
2. A manufactured home (mobile home) installation must conform with the Manufactured Home Construction and Safety Standard, Title 24 CFR, Part 3280, or, when such a standard is not applicable, the Standard for Manufactured Home Installations, ANSI A225.1/NFPA 501A.
3. Clothing or other flammable material should not be placed on or near the appliance.
4. The flow of combustion and ventilation air must not be obstructed.

5. This appliance gives off high temperatures and should be located out of heavy traffic areas and away from furniture and draperies.

6. Children and adults should be alerted to the hazards of the high surface temperatures of this appliance and should stay away to avoid burns or ignition of clothing.

7. Children should be carefully supervised when they are in the same room as the fireplace.

8. Under no circumstances should this appliance be modified. Do not operate this appliance if any parts have been removed for service.

9. Installation and any repairs to this appliance should be done by a qualified service person. A professional service person should be called to inspect this appliance annually. Make it a practice to have all of your gas appliances checked annually.

10. Control compartments, burners and air passages in this appliance should be kept clean and free of dust and lint. Make sure that the gas valve and pilot light are turned off before you attempt to clean this unit.

11. The appliance's venting system should be inspected at least once a year and immediately cleaned if necessary.

12. Keep the area around the appliance clear of combustible materials, gasoline and other flammable vapors and liquids. Do not use this appliance as a drying rack for clothing, nor should Christmas stockings or decorations be hung in its immediate area.

13. Do not operate this appliance without glass in place. Replace damaged glass only with equivalent glass of equal thickness and size (available from your dealer).

14. Never burn solid fuel (wood, paper, cardboard, coal) in this appliance.

15. Do not use this appliance if any part has been under water. Immediately call a qualified service technician to inspect the heater and to replace any part of the control system and any gas control which has been under water.

16. The glass must be replaced in the door, (if removed for service) before operating the appliance.

## GAS SPECIFICATIONS

MODEL	FUEL	GAS CONTROL	MAXIMUM INPUT
9660N	Natural	Remote On/Off	24,000 BTU/HR
9660L	Propane/LP	Remote On/Off	20,000 BTU/HR
Manifold Pressure - Natural Gas 3.5" water column pressure Propane/LP Gas 10" water column pressure			
Gas Inlet - 3/8" NPT			
SUPPLY	MINIMUM PRESSURE*	MAXIMUM PRESSURE	
NATURAL GAS	5" W.C.P.	10.5" W.C.P.	
PROPANE/LP GAS	11.0" W.C.P.	13.0" W.C.P.	

\*For the purpose of Input Adjustment.

# GAS FURNACE DIMENSIONS

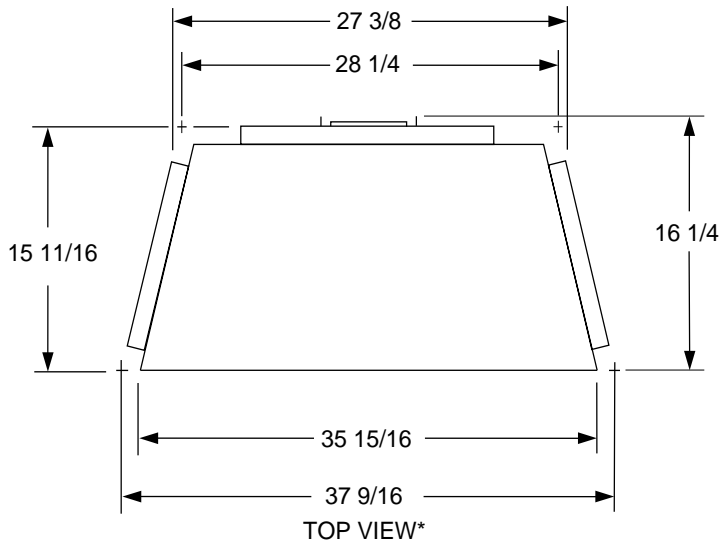

\*TOP VIEW SHOWN WITHOUT FURNACE TRIM FOR CLARITY.

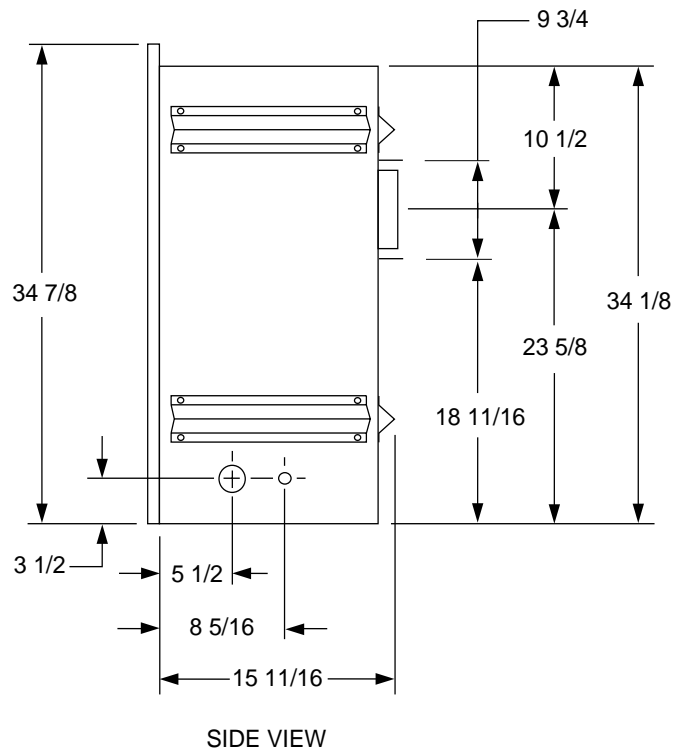
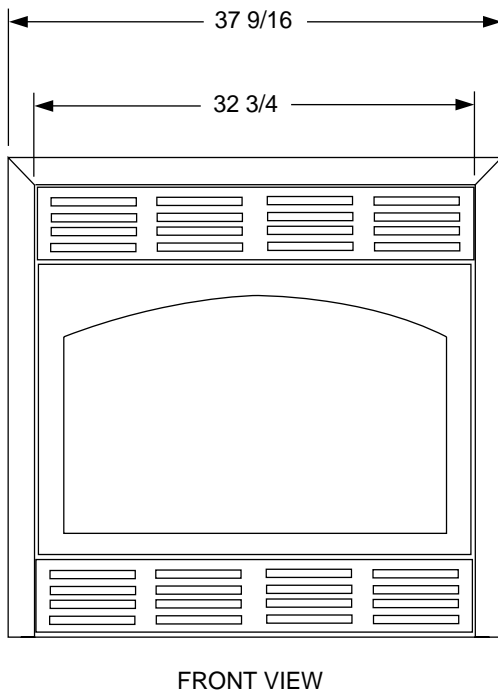

## PLANNING YOUR FURNACE INSTALLATION

### OPENING OF DOOR

- ① Remove top grill
- ② Lower bottom grill by pulling down knob.
- ③ Unlatch door and swing door down.

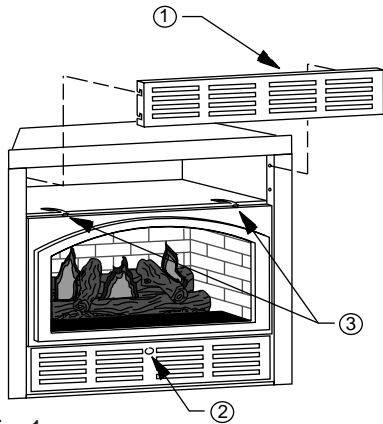

Fig. 1

**CAUTION: DO NOT ATTEMPT TO OPEN DOOR WHILE UNIT IS HOT.**

### LOCATING YOUR FURNACE

- (A) Flat on wall (C) \*Flat on wall corner  
(B) Cross corner (D) Cantilever

**NOTE:** \*When you install your fireplace in (C) Flat or wall corner positions, a minimum of 6 inches clearance must be maintained from the perpendicular wall and the front of the appliance.

The 9660 Gravity type vented wall furnace may be installed flat on a combustible-floor or raised up on a hearth to keep the flame at eye level. If the appliance is installed directly on carpeting, tile or other combustible material other than wood flooring, the appliance must be installed on metal or wood panel extending the full width and depth of the appliance.

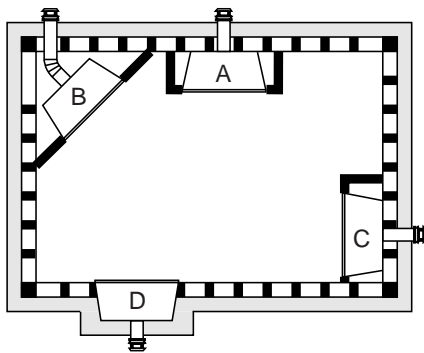

Fig. 2

## FRAMING AND FINISHING

1. Choose furnace location and frame opening as illustrated below in figure 3, 4a & 4b.
2. Place furnace into position and secure to floor with nail flanges.
3. Cold climate recommendation: When installing this furnace against a non-insulated exterior wall or chase, it is recommended that the outer walls be insulated to conform to applicable insulation codes.

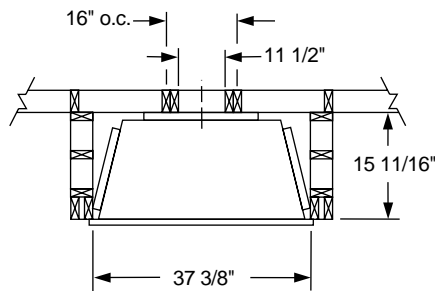

Fig. 3

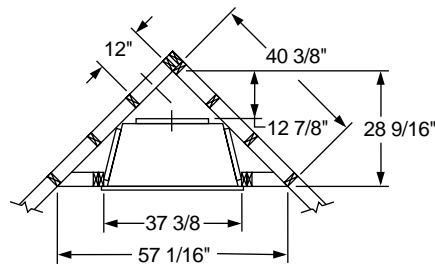

Fig. 4a

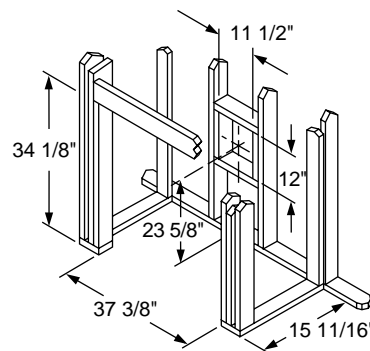

Fig. 4b

**Minimum wall thickness:**  
4 inches  
**Maximum wall thickness:**  
6 inches

## HEARTH

A hearth is not required, but it will improve the appearance and provide added safety. We recommend a noncombustible hearth which extends a minimum of 12 inches in front of the appliance.

## MANTELS

The height at which a mantel must be placed above the furnace opening depends on the depth of the mantel. See drawing and chart (Fig. 5 & 6) for proper installation height of a combustible mantel piece. Non-combustible mantels may be installed at any height above the furnace opening.  
**NOTE:** Use heat resistant paint or finish on the mantel to prevent discoloration.

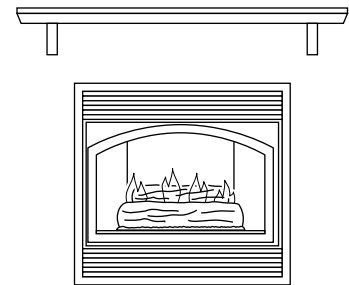

Fig. 5

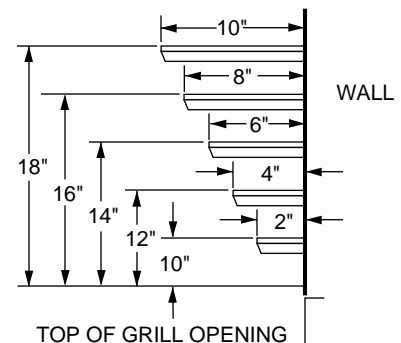

Fig. 6 - Mantel Chart

## CLEARANCE TO COMBUSTIBLES

BACK	0 inches from standoffs
SIDES	0 inches from standoffs
FLOOR	0 inches
TOP	0 inches
CEILING	30 inches
SIDE WALL	6 inches

Non-combustibles materials such as brick, stone or tile must extend flush with or project in front of and/or on the face of the fireplace but must not block any of the grill openings or fire chamber opening.

THIS APPLIANCE IS FOR USE WITH NATURAL OR PROPANE/LP GAS ONLY AS INDICATED ON RATING PLATE.

NOTE: BTU ratings shown on the rating plate area are for elevations up to 2,000 feet. For elevations above 2,000 feet, rating should be reduced at the rate of four (4) percent for each 1,000 feet above sea level.

**OPTIONAL BLOWER KIT.  
MODEL# B60**

- Kit includes:**
- 1-Blower Assembly
  - 1-Speed Control Switch
  - 1-Hardware Pack

The appliance, when installed, must be electrically grounded in accordance with local codes or, in the absence of local codes, with the latest edition of the National Electrical Code, ANSI/NFPA 70 or current.

**INSTALLATION**

1. Open bottom louver door.
2. Slide fan assembly into opening, line up the mounting holes with the screw studs protruding from the floor panel and secure with the (2) nuts provided.
3. Install electrical wiring.

See B60 - Blower Kit instruction sheet for more details (supplied with kit).

**NOTE:** Electrical wiring and installation must conform to all applicable codes and ordinances and must be done by a qualified electrician.

**CAUTION:** Electrical power supply must be disconnected prior to servicing the fan.

**GAS PIPE AND BURNER  
INSTALLATION**

Installation must conform to local codes, or in the absence of local codes, to the latest edition of the National fuel Gas Code, ANSI Z 223.1-1992.

A. An accessible manual shut-off valve is required in the gas supply line. A ground joint union is required in the gas supply line to provide for burner removal or servicing.

B. When a vertical section of piping is required for installation, a condensation trap (drip leg) is required.

C. For natural gas, a minimum of 3/8" iron pipe with gas pressure of 5 WC must be used for supply from the meter. Consult with the local gas utility for any questions concerning pipe size.

D. A 1/8" NPT plugged tapping, accessible for test gauges connection, must be installed immediately up stream of the gas supply connection to the appliance.

E. Make gas connection to burner assembly with pipe or listed flexible connection. Seal space between pipe and knockout on firebox with high temp caulk. See Figure 7.

F. Turn gas supply on and check for leaks using a soap and water solution. (DO NOT USE AN OPEN FLAME).

**NOTE:** The appliance and its individual shut-off valve must be disconnected from the gas supply piping system during any pressure testing where the test pressure is in excess of 1/2 psig. The appliance must be isolated from the gas supply piping system by closing its individual manual shut-off valve during any pressure testing of the gas supply piping system at test pressure equal to or less than 1/2 psig.

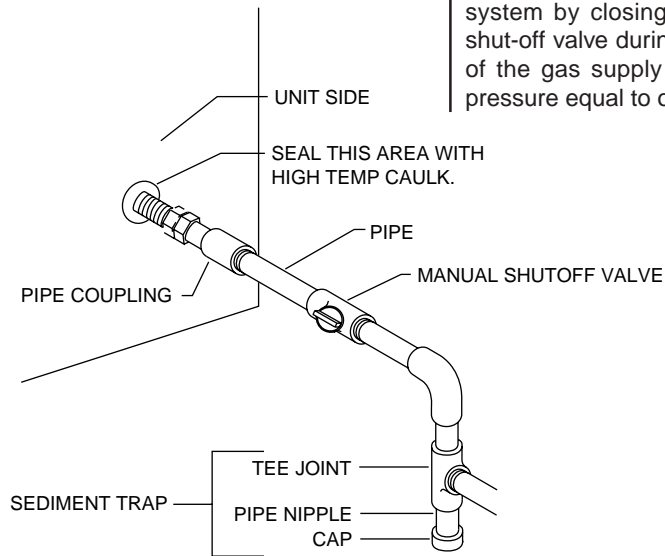

Fig. 7

**INSTALLATION OF LOGS**

1. Place large rear logs against back support bracket, flat spots up.
2. Place front log against front support bracket, flat spots.
3. Place smaller top logs on flat spots of bottom logs as shown in Figure 8.
4. Close Glass Door.

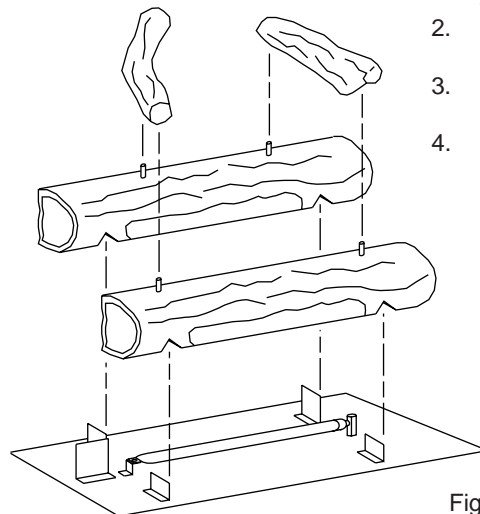

Fig. 8

## OPERATION AND MAINTENANCE

**WARNING:** WHEN PURGING THE GAS LINE, THE GLASS FRONT MUST BE REMOVED.

### LIGHTING PROCEDURE (Fig.9)

1. Depress and turn gas valve knob (A) to "off". Wait sufficient time to allow gas which may have accumulated in the burner compartment to escape. (At least 5 minutes.)
2. Depress valve knob and turn to "pilot".
3. Depress and hold valve knob while pushing Piezoelectric spark lighter (B). [If pilot does not light using the piezoelectric spark lighter, the pilot can also be lit by placing a match near the pilot while depressing the valve knob] Hold valve knob depressed until pilot remains lit when knob is released (approximately 10 seconds).
4. Turn valve knob to "ON".
5. Wait approximately one minute then turn burner switch (C) to "ON".
6. If unit fails to start, repeat steps one through five.

**NOTE:** If unit is equipped with remote "on-off" wall switch, switch must be in "on" position for burner to light.

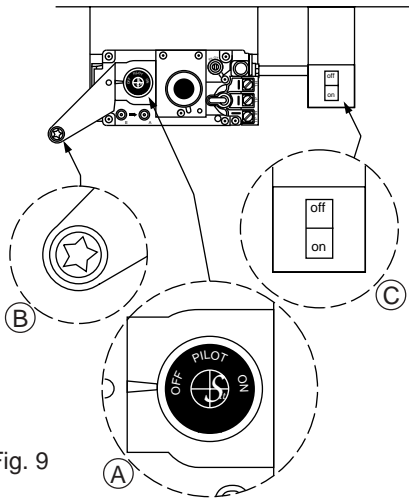

Fig. 9

**NOTE:** The gas control is designed to be either fully on or off. Never use control to vary flame height.

**NOTE:** It is normal for the new furnace to give off some odor the first time it is burned. This is due to the curing of the paint and any undetected oil from the manufacturing process. It is recommended that you burn your new fireplace for at least two (2) hours the first time you use it. If optional fan kit is installed, leave it turned off during this break-in period.

## SHUT-DOWN PROCEDURE

1. To turn off the Main Burner only, use Main Burner switch or turn Valve Knob to "PILOT" position.
2. For complete shut down, slightly depress Valve Knob, turn to "OFF" position.
3. The Burner Assembly has been pre-adjusted for proper flame control. DO NOT ALTER GAS ORIFICE. Unless converting from LP to Natural or Vice Versa.
4. Periodic visual checks of the Pilot Flame should be conducted to ensure that the flame is continuously present except when the valve knob is in the "OFF" position.

## PILOT BURNER

### ADJUSTMENT (Fig. 10)

1. Adjust pilot key to provide properly sized flame. The flame should cover the upper 3/8" of the tip.
2. Test for leaks.

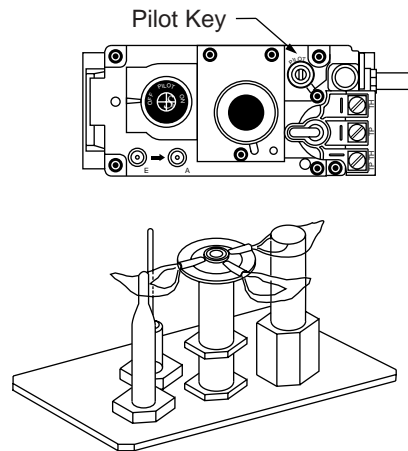

Fig. 10 - Pilot flame adjustment

## MAINTENANCE

**It is important to keep burner and the burner compartment clean. This must be done periodically, at least once per season.**

### Steps for Cleaning Procedure:

1. Turn off pilot.
2. Open glass door frame assembly.
3. Remove logs.
4. Vacuum burner compartment, especially around the orifice opening.
5. Reinstall logs.
6. Close glass door frame.

7. Ignite pilot - see Lighting Procedure Section.
8. Operate the burner and visually check to make sure the flame pattern appears similar to Figure 11.

**NOTE:** It is important to periodically perform a visual check of the pilot and the burner flame and to compare then with this illustration.

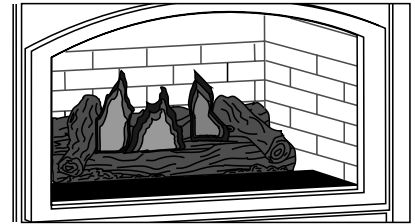

Fig. 11

## ADJUSTING THE FLAME

If flame is too low:

1. Open the glass door.
2. Remove the (2) top small logs and the front log.
3. Adjust the flame higher by closing the air shutter using a standard phillips screwdriver.

If flame is too high:

1. Open the glass door.
2. Remove the (2) top small logs and the front log.
3. Adjust the flame lower by opening the air shutter slightly using a standard phillips screwdriver.
4. **CAUTION:** Do not open the air shutter to the point where the flame is lifting off of the burner.

**NOTE:** If you cannot achieve sufficient flame height, contact your local gas supplier to check for proper gas pressure.

## GLASS CLEANING

It will be necessary to clean the glass periodically. During start-up, condensation forms on the inside of the glass and causes dust, lint, etc. to cling to the glass surface. This is normal. Also, initial paint curing can deposit a slight film on the glass.

**DO NOT CLEAN GLASS WHEN IT IS HOT.**  
**DO NOT USE ABRASIVE CLEANERS ON GLASS OR DOOR.**

**IMPORTANT! THE VENT-AIR INTAKE SYSTEM MUST BE PROPERLY INSTALLED TO INSURE PROPER AND SAFE OPERATION. THE VENT-AIR INTAKE SYSTEM MUST BE PROPERLY REINSTALLED AND RESEALED TO INSURE PROPER AND SAFE OPERATION. FOR MANUFACTURED HOME (MOBILE HOME) INSTALLATION: "THIS APPLIANCE MUST BE INSTALLED IN ACCORDANCE WITH THE MANUFACTURER'S INSTRUCTIONS AND THE MANUFACTURER'S HOME CONSTRUCTION AND SAFETY STANDARDS, TITLE CFR, PART 3280"**

## VENTING INSTRUCTIONS

The Model 9660 furnace is designed for direct venting through a side wall or roof. Only venting components specifically approved and labeled for this furnace may be used. The flow of combustion and ventilation air must not be obstructed. Minimum clearance between vent pipes and combustible materials is one (1) inch.

**CAUTION: ALL JOINTS MUST BE AIR-TIGHT.**

THE INSTALLATION OF THIS APPLIANCE MUST CONFORM WITH LOCAL CODES, OR IN THE ABSENCE OF LOCAL CODES, WITH THE LATEST EDITION OF THE NATIONAL FUEL GAS CODE, ANSI 223.1 (Latest Edition).

### SIDE WALL VENTING Location of Vent Termination

**IMPORTANT:** The minimum clearances given for the vent termination must be strictly adhered to. There must not be any obstruction such as bushes, fences, garden sheds, decks or utility buildings within 24" from the front of the termination hood.

Do not locate termination hood where excessive snow or ice buildup may occur. Check vent termination area after snowfalls, and clear to prevent potential blockage of venting system. When using snow blowers, make sure snow is directed away from the vent termination area.

**The vent termination must not be located:**

1. Less than 7 feet above a paved sidewalk or a paved driveway located on public property.
2. Within 6 feet of a mechanical air supply inlet to any building.
3. Above a meter/regulator assembly within 3 feet horizontally of the vertical center-line of the regulator.
4. Within 6 feet of any gas service regulator vent outlet.
5. Less than 1 foot above grade level; (see section on below ground installation for special venting.)
6. Within the following distances of a window or a door which can be opened, any non-mechanical air supply inlet or the combustion air inlet of another appliance;
  - a. 12 inches top and sides.
  - b. 4 feet below.
7. Underneath a veranda, porch or deck where,
  - a. the veranda, porch or deck is fully open on a minimum of two sides beneath the floor.
  - b. the distance between the top of the vent termination and the underside of the veranda, porch, or deck is less than 4 feet.

V - Vent Termination  
 M - Mechanical Air  
 GM - Gas Meter  
 R - Regulator

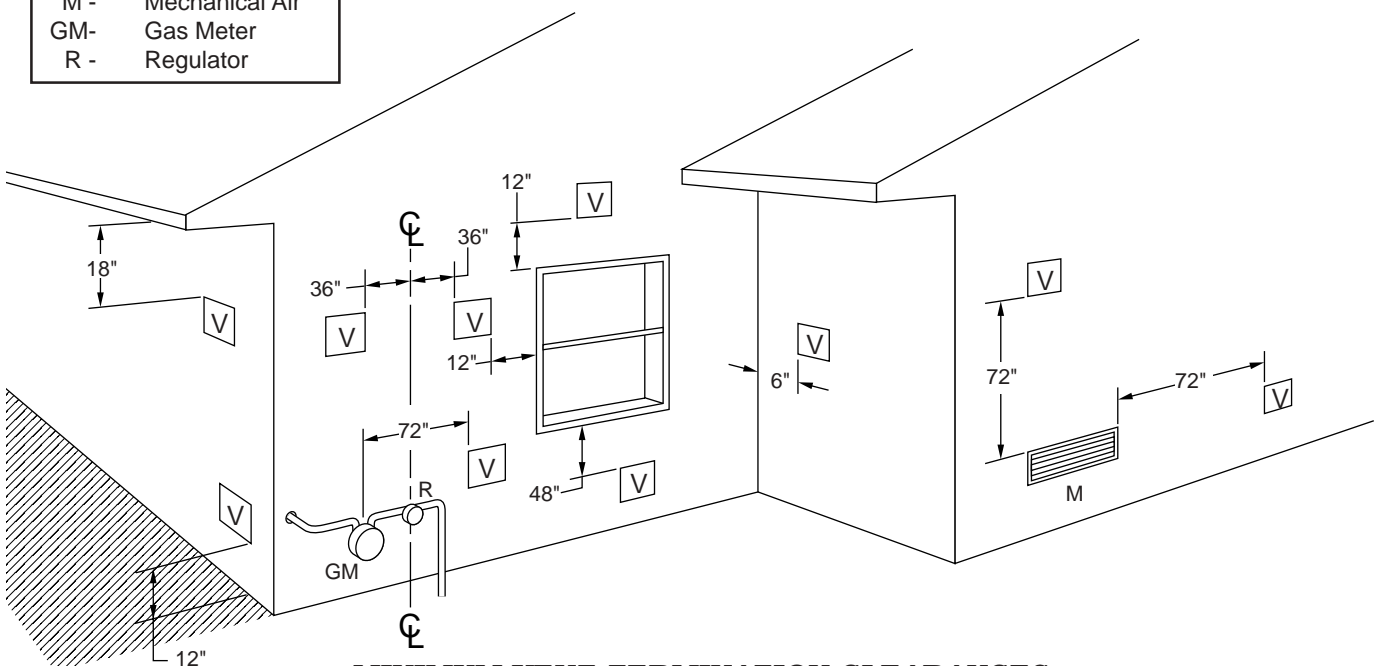

**MINIMUM VENT TERMINATION CLEARANCES**  
 From combustibles exterior surfaces, gas meter, air intakes, etc.

## VENTING INSTRUCTIONS

If the exterior of the building is **non-combustible** the following minimum clearances are applicable:

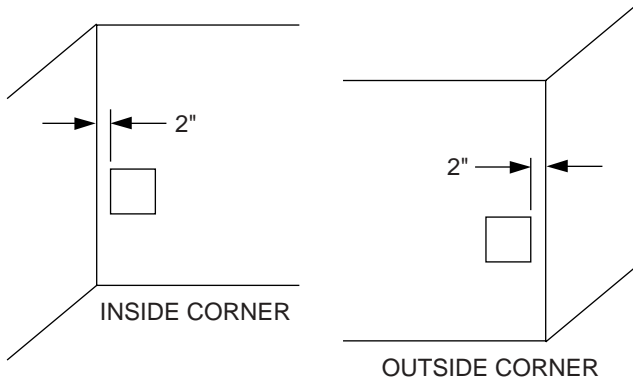

If exterior of the building is **combustible** the following minimum clearances are applicable.

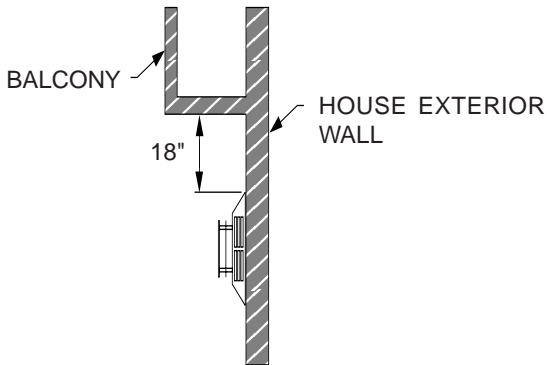
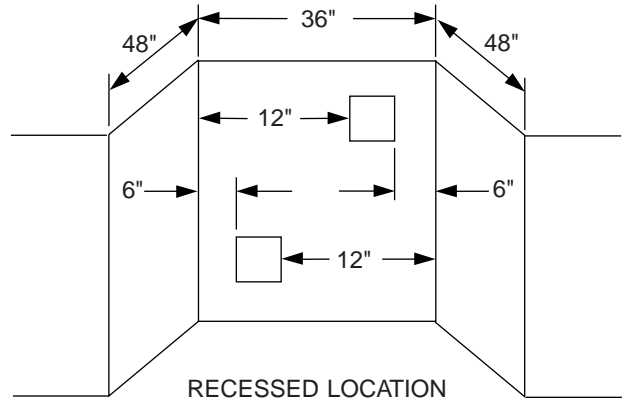
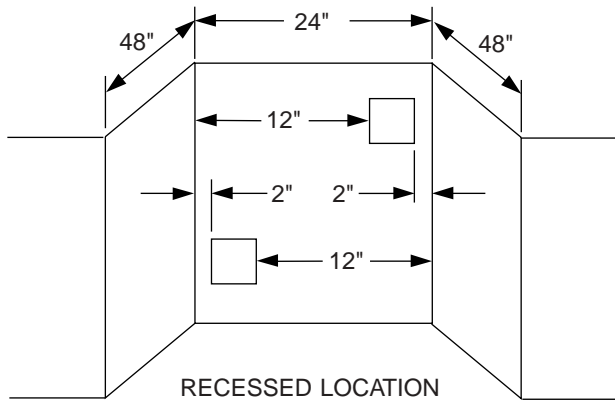
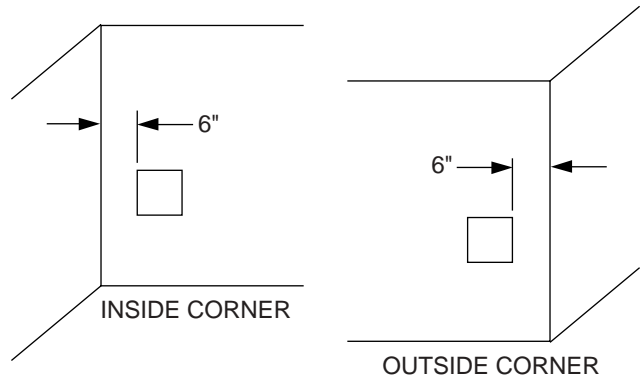

BALCONY - NO SIDE WALL (CROSS SECTION)

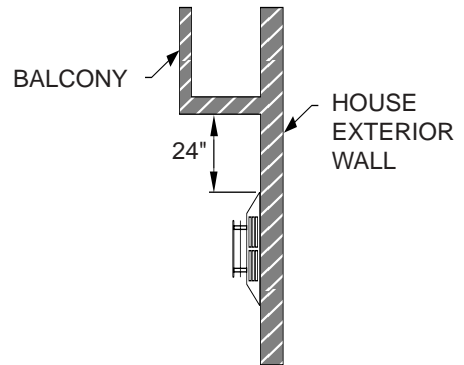

BALCONY - NO SIDE WALL (CROSS SECTION)

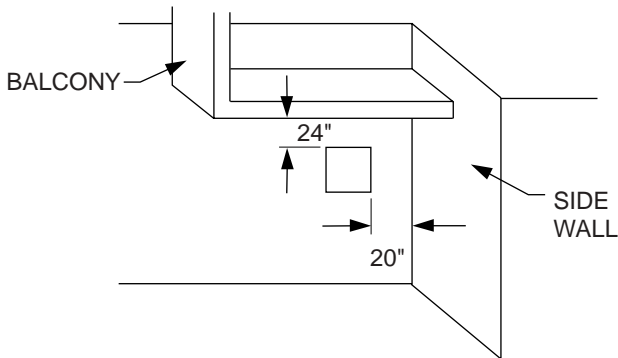

BALCONY WITH PERPENDICULAR SIDE WALL

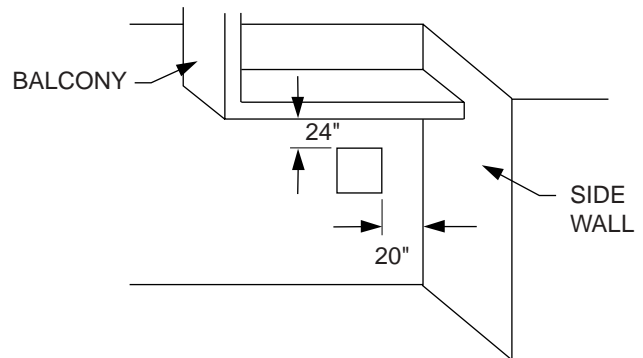

BALCONY WITH PERPENDICULAR SIDE WALL

# VENTING TABLES

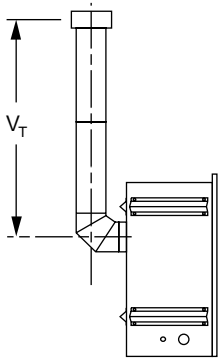

TABLE A

TABLE A	
$V_T = 40'$ Max.	

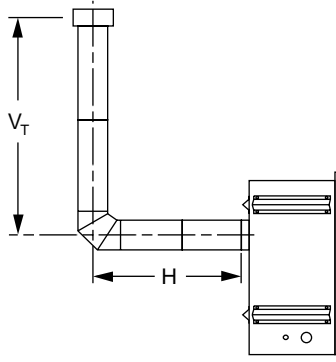

TABLE B

TABLE B	
$V_T$ Min.	H Max.
1	2
2	4
3	6
4	8
5	8
$V_T = 40$ Max. $H = 8'$ Max.	

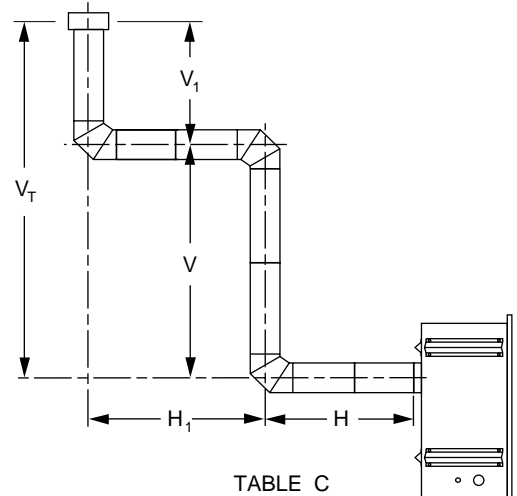

TABLE C

TABLE C			
V Min.	H Max.	H+H <sub>1</sub> Max.	V <sub>1</sub> Max.
1	2	2	39
2	4	4	38
3	6	6	37
4	8	8	36
5	8	10	35
6	8	12	34
7	8	14	33
8	8	16	32
9	8	16	31
$V_T = V + V_1 = 40'$ Max. $H = 8'$ Max.			

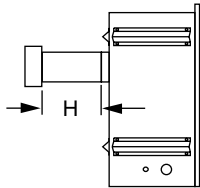

TABLE D

TABLE D	
$H = 12''$ Min.	
$H = 24''$ Max.	

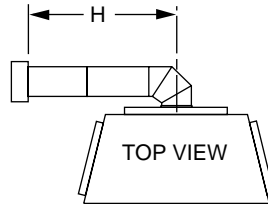

TABLE E

TABLE E	
$H = 12''$ Min.	
$H = 24''$ Max.	

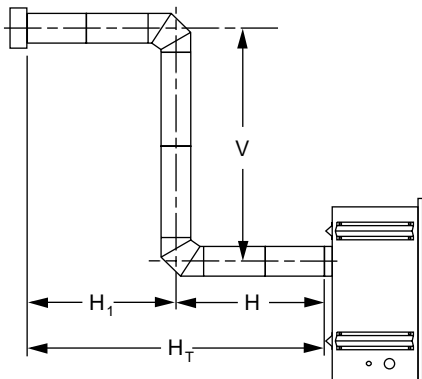

TABLE F-1

TABLE F		
V Min.	H Max.	H+H <sub>1</sub> Max.
1	2	2
2	4	4
3	6	6
4	8	8
5	8	10
6	8	12
7	8	14
8	8	16
9	8	16
$V = 20'$ Max. $H = 8'$ Max. $H_T = H + H_1 = 16'$ Max.		

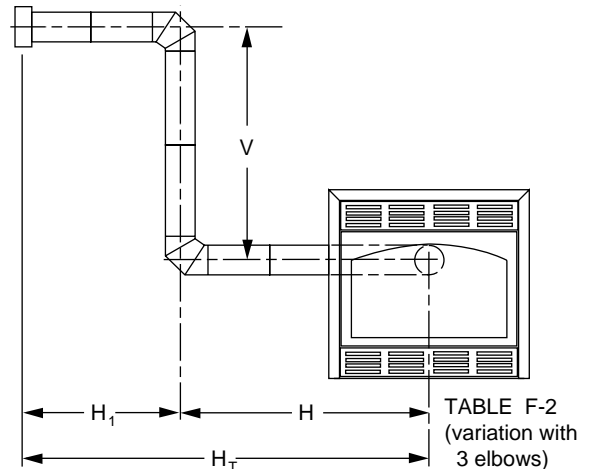

TABLE F-2  
(variation with 3 elbows)

## INFORMATION ON VENTING ROUTES AND COMPONENTS

Since it is very important that the vent system maintain its balance between the combustion air intake and the flue gas exhaust, certain limitations as to vent configurations apply and must be strictly adhered to.

- Max. vertical vent run is 40 ft.
- Max. horizontal vent run is 16 ft.
- A 1/4" rise per foot of horizontal run must be maintained on all horizontal runs.
- It is possible to configure a venting system with 40 feet of vertical vent run and 16 feet of horizontal vent run and include up to (3) three elbows. (See venting tables on page 9.)

**IMPORTANT:** It is always best to locate the furnace in such a way that a minimum of offsets and/or horizontal run is required.

## INSTALLATION

### PLANNING YOUR INSTALLATION

When planning your installation, it will be necessary to select the proper length of vent pipe for your particular requirements. To determine the length of vent pipe required for vertical installations, measure the distance from the appliance flue outlet to the ceiling, the ceiling thickness, the vertical rise in an attic or second story, and allow for sufficient vent height above the roofline. For two-story applications, firestops are required at each floor level. If an offset is needed in the attic, additional pipe and elbows will be required.

### HORIZONTAL INSTALLATION

#### STEP 1:

Set the gas appliance in its desired location. Check to determine if wall studs or roof rafters are in the way when the venting system is attached. If this is the case, you may want to adjust the location of the appliance.

#### STEP 2:

Direct Vent pipe and fittings are designed with special twist-lock connections. To connect the venting system to the appliance flue outlet, we have supplied a twist-lock appliance adaptor built into the unit at the factory.

(1) Twist-lock procedure: Four indentations, located on the female ends of pipes and fittings, are designed to slide straight onto the male ends of adjacent pipes and fittings, by orienting the four pipe indentations so they match and slide into the four entry slots on the male ends. (Figure 12) Push the pipe sections completely together, then twist-lock one section clockwise approximately one-quarter turn, until the two sections are fully locked. The female locking lugs will not be visible from the outside, on the Black Pipe or fittings. They may be located by examining the inside of the female ends.

(2) Horizontal runs of vent must be supported every three feet. Wall Straps are available for this purpose.

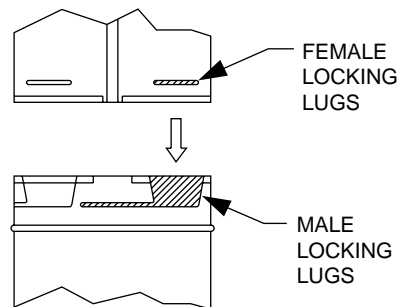

Fig. 12

#### STEP 3:

With the adaptor and pipe attached to the stove into its correct location, and mark the wall for a 11 1/2-inch x 12-inch square hole. The center of the square hole should line up with the centerline of the horizontal pipe, as shown in Figure 13. Cut and frame the square hole in the exterior wall where the vent will be terminated. If the wall being penetrated is constructed of non-combustible material, i.e. masonry block or concrete, a 7-inch diameter hole is acceptable.

(1) The horizontal run of vent must have a 1/4-inch rise for every 1 foot of run towards the termination. Never allow the vent to run downward. This could cause high temperatures and may present the possibility of a fire.

(2) The location of the horizontal vent termination on an exterior wall must meet all local and national building codes, and must not be easily blocked or obstructed. Termination clearances are given on page 7 & 8.

#### STEP 4:

Position the horizontal vent termination in the center of the 11 1/2" x 12" hole, and attach to the exterior wall with the four wood screws provided. Before attaching the Vent Termination to the exterior wall, run a bead of non-hardening mastic around its outside edges, so as to make a seal between it and the wall. The arrow on the vent cap should be pointing up. Insure that proper clearances to combustible materials are maintained. (Figure 14)

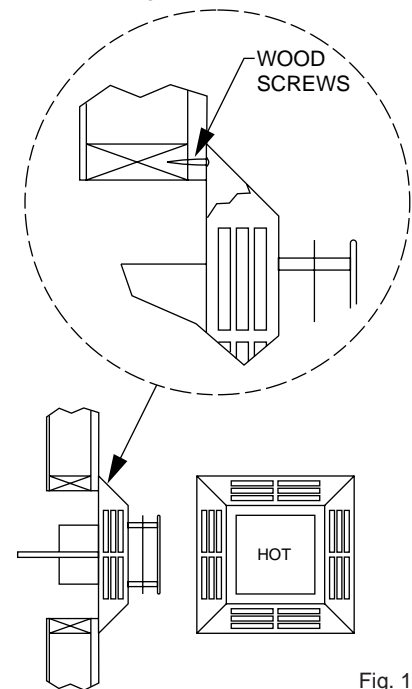

Fig. 13

#### NOTE:

(1) The four wood screws provided should be replaced with appropriate fasteners for stucco, brick, concrete, or other types of sidings.

(2) For buildings with vinyl sidings, a Vinyl Siding Standoff (Part 950), should be installed between the vent cap and the exterior wall. (Figure 14). Attach the Vinyl Siding Standoff to the Horizontal Vent Termination. The Vinyl Siding Standoff prevents excessive heat from possibly melting the vinyl siding material.

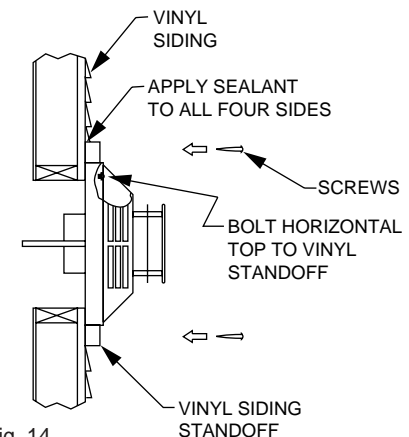

Fig. 14

## VERTICAL TERMINATION

### STEP 1:

Set the gas appliance in its desired location. Drop a plumb bob from the ceiling to the position of the appliance flue exit, and mark the location where the vent will penetrate the ceiling. Drill a small hole at this point. Next, drop a plumb bob from the roof to the hole previously drilled in the ceiling, and mark the spot where the vent will penetrate the roof. Determine if ceiling joists, roof rafters, or other framing will obstruct the venting system. You may wish to relocate the appliance, or to offset, as shown in Figure 15, to avoid cutting loadbearing members.

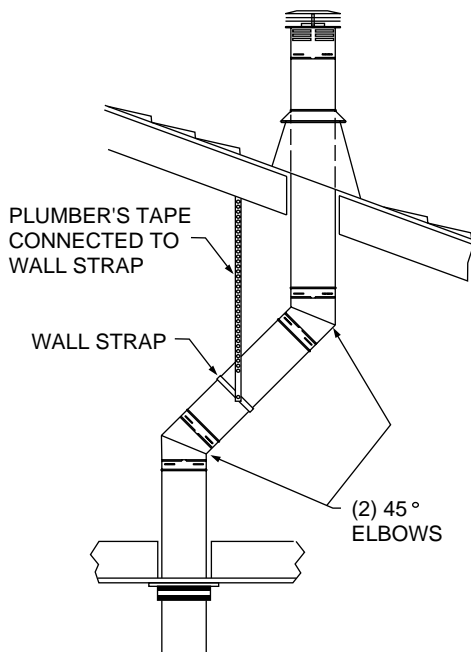

Fig. 15

### STEP 2:

To install the round support box/wall thimble in a flat ceiling, cut a 11 1/2" x 12" hole in the ceiling, centered on the hole drilled in Step 1. Frame the hole as shown in Figure 16.

### STEP 3:

Assemble the desired lengths of Pipe and Elbows necessary to reach from the Appliance adaptor up through the Round Support box. Insure that all Pipe and Elbow connection are in their fully twist-licked position.

### STEP 4:

Cut a hole in the roof centered on the small drill hole placed in the roof in STEP 1. The hole should be of sufficient size to meet the minimum requirements for clearance to combustibles, as specified on page 8. Continue to assemble lengths of Pipe and Elbows necessary to reach from the Ceiling Support Box up through the roof line. A galvanized finish is desirable above the roofline, due to its higher corrosion resistance.

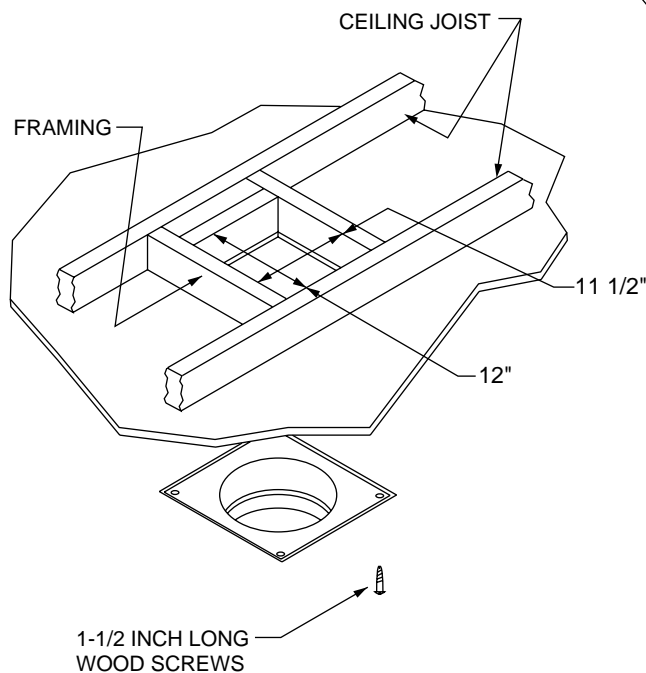

Fig. 16

(1) If an offset is necessary in the attic to avoid obstructions, it is important to support the vent pipe every 3 feet, to avoid excessive stress on the Elbows, and possible separation. Wall Straps are available for this purpose.

(2) Whenever possible, use 45 degrees Elbows, instead of 90 degrees Elbows. The 45 degrees Elbows offers less restriction to the flow of flue gases and intake air.

### STEP 5:

Slip the flashing over the Pipe Section(s) protruding through the roof. Secure the base of the Flashing to the roof with roofing nails. Insure the roofing material overlaps the top edge of the Flashing as shown in Figure 18. Verify that you have at least the minimum clearance to combustibles at the roofline.

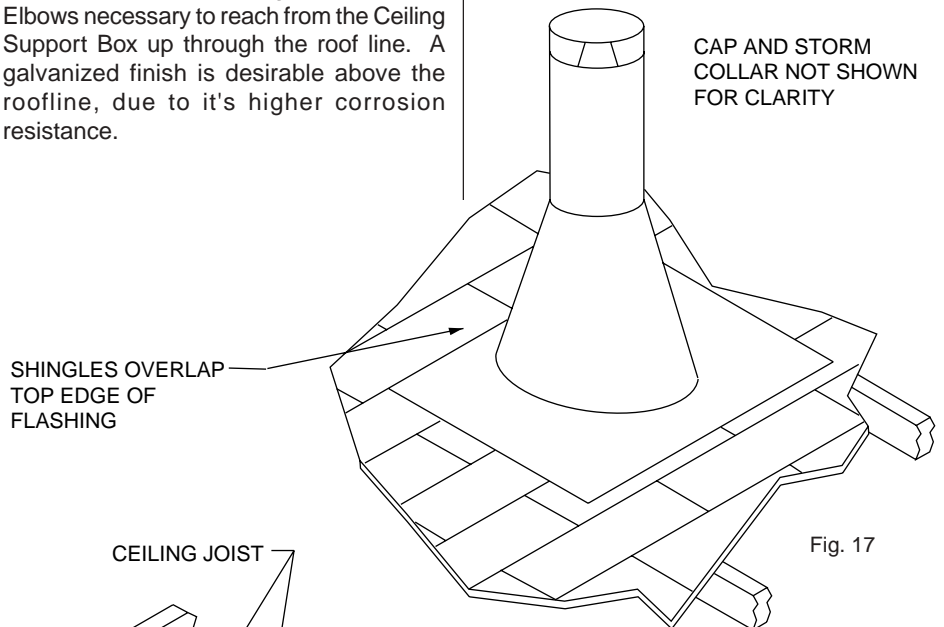

Fig. 17

**STEP 6:**

Continue to add pipe sections until the height of the Vent Cap meets the minimum building code requirements described in figure 18. Note that for steep roof pitches, the vent height must be increased. In high wind conditions, nearby trees, adjoining rooflines, steep pitched roofs, and other similar factors can result in poor draft, or down-drafting. In these cases, increasing the vent height may solve this problem.

**STEP 7:**

Twist lock the Vent Cap.

**NOTE:**

(1) For multistory vertical installations, a Ceiling Firestop is required at the second floor, and any subsequent floors. (Fig. 19) The opening should be framed to 11-1/2-inch x 12-inch inside dimensions, in the same manner as shown in Figure 16, page 11.

(2) Any occupied areas above the first floor, including closets and storage spaces, which the vertical vent passes through, must be enclosed. The enclosure may be framed and sheetrocked with standard construction materials, see page 8 for minimum allowable clearance between the outside of the vent pipe, and the combustible surfaces of the enclosure. Do not fill any of the required air spaces with insulation.

**IMPORTANT NOTICE:**

If for any reason it becomes necessary to remove the unit for maintenance and the Dura-vent pipe is detached, the piping **MUST** be resealed using HEAT SAFE high temperature sealant, available at your local hearth and heating store.

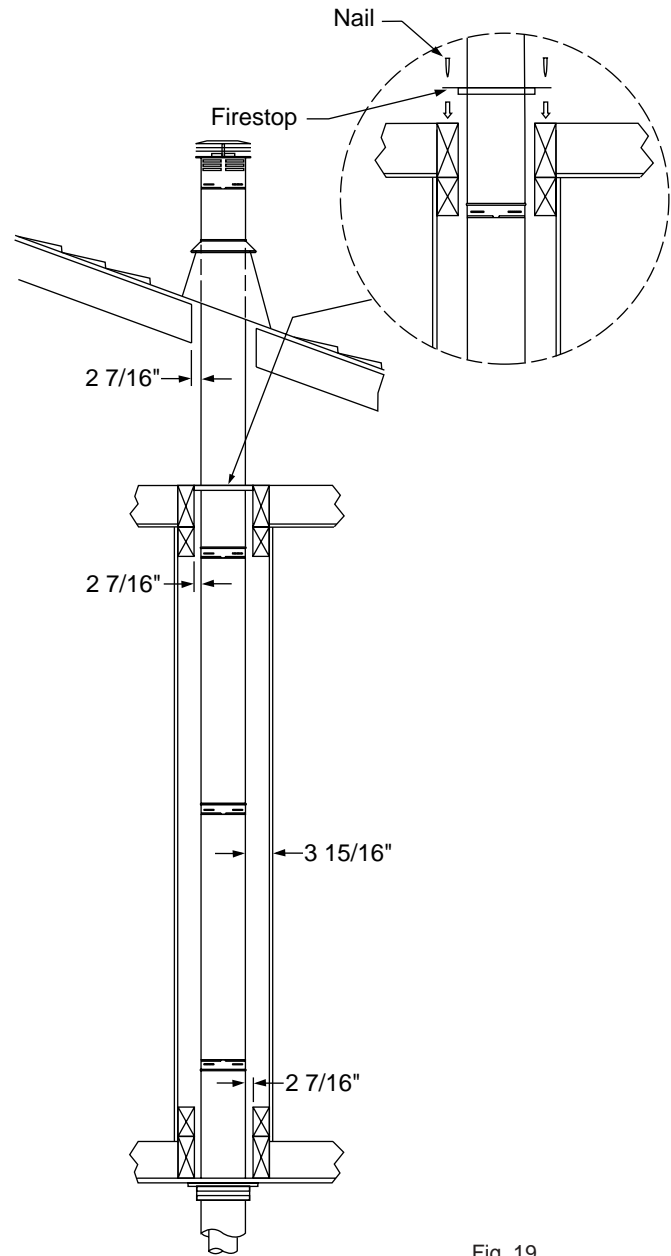

Fig. 19

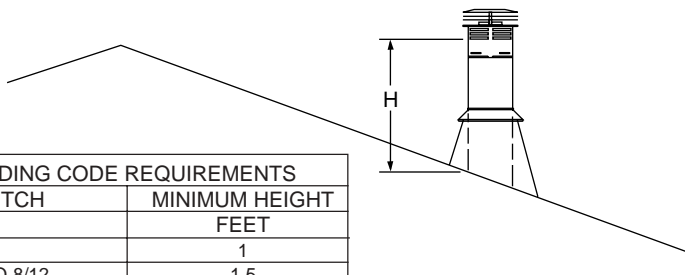

Fig. 18

BUILDING CODE REQUIREMENTS	
ROOF PITCH	MINIMUM HEIGHT FEET
FLAT TO 7/12	1
OVER 7/12 TO 8/12	1.5
OVER 8/12 TO 9/12	2
OVER 9/12 TO 10/12	2.5
OVER 10/12 TO 11/12	3.25
OVER 11/12 TO 12/12	4
OVER 12/12 TO 14/12	5
OVER 14/12 TO 16/12	6
OVER 16/12 TO 18/12	7
OVER 18/12 TO 20/12	7.5
OVER 20/12 TO 21/12	8

## GAS PRESSURE REQUIREMENTS

**The number one cause of all operating problems with gas appliances is improper gas pressure!**

Such problems as changes in flame color or configuration, gas pilot or burner outages, intermittent operation, changes in heat output, excessive burner noise, etc., are nearly always the result of changes in gas pressure or improper gas pressure at the time of the installation.

The most important item to check during the initial installation and the first thing to check when operating problems occur is gas pressure!

Gas supplies normally enter a typical residence at 1/2 PSI (13"-15"W.C.) (3.KPA). A regulator is then placed inside the residence which drops this pressure to 7" W.C. (1.8KPS) (Nat. Gas).

This "inches to inches" regulator is of adequate capacity to service the gas appliances such as water heater, dryer, furnace, etc.

If this regulator's capacity is not sufficient to add the Model 9660, an additional "inches to inches" regulator must be installed specifically for the fireplace. EXCEPTION: some codes allow 2 PSI (1.4KPA) supplies to enter the residence, in which case "pounds to inches" regulators are used.

The following table provides information on correct gas pressure requirements. **Be sure your gas supplier or plumber carefully follows this table when installing your gas appliance.**

	DESIRED PRESSURE	MINIMUM PRESSURE	MAXIMUM PRESSURE	MANIFOLD PRESSURE	AIR SHUTTER POSITION
<b>NATURAL</b>	7.0" W.C.	5.0" W.C.*	10.5" W.C.	3.5" W.C.	5/16" OPEN
<b>L.P.</b>	11.0" W.C.	10.0" W.C.*	13.0" W.C.	10" W.C.	5/16" OPEN

\*For the Purpose of Input Adjustment.

## MILLIVOLT SYSTEM CHECK

The millivolt system and individual components may be checked with a millivolt meter having a 0-1000 MV range. Before checking the system, be certain the wall thermostat lead wire does not exceed the length recommended in the Wiring Section Table, and all connections are clean and tight.

Conduct each check shown in the chart below by connecting meter test leads to terminals as indicated. All readings are closed circuit.

Component Check	Connect Meter Test Leads To Terminals	Wall Thermostat Contacts Should Be	Meter Reading Should Be	See Check Results Below
<b>Valve Operator System</b>	2 & 3	Closed	Greater Than 100 MV	A
<b>Wall Thermostat</b>	1 & 3	Closed	Less Than 80 MV	C
<b>Thermopile and Magnet</b>	1 & 2	Open	Greater Than 325 MV	B

### A. TEST RESULTS

If the reading is more than 100 millivolts and the automatic valve does not come on, replace the valve operator. If the closed circuit reading is less than 100 millivolts, determine the cause by preceding with steps "B" and "C".

### B. TEST RESULTS

If "B" reading is less than 325 MV, clean and tighten all electrical connections and adjust pilot if necessary to increase millivolt output. If unable to adjust to at least the specified minimum, change the thermopile. When proper thermopile output is obtained, the magnet may then be checked. With pilot in operation, allow meter reading to stabilize. Extinguish pilot burner and note meter reading at dropout point of magnet. If magnet remains locked up to a reading of 120 MV or less, the magnet is good.

### C. TEST RESULTS

If "C" reading is more than that specified for the system being checked, clean and tighten thermostat leads and connection, shorten lead wires if possible or use heavier gauge wire. Rapidly cycle thermostat to clean contacts, or change the thermostat.

## TESTING MANIFOLD AND INLET PRESSURE

To test the Manifold gas pressure and Inlet gas pressure in the field, simply follow the instructions below.

NOTE: Manometer attachment may be accomplished by sliding a rubber tube connected to the manometer to the pressure taps.

1. Locate the Manifold and Inlet pressure taps on the control. (See Figure 20)  
NOTE: The following instructions apply for both the Manifold and Inlet pressure tests.
2. With a small screwdriver, rotate the screw in the pressure tap "counter-clockwise" until loosened. NOTE: Screw is designed not to come completely out.
3. Attach Manometer to pressure tap and take reading.
4. Once testing is complete, rotate the pressure tap screw "clockwise" and tighten securely.

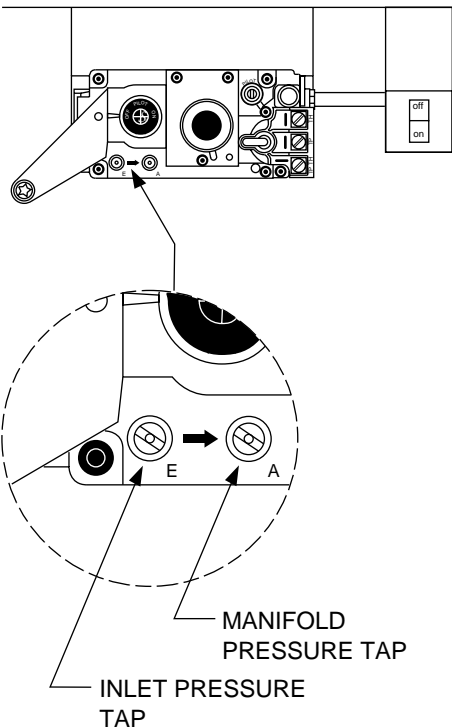
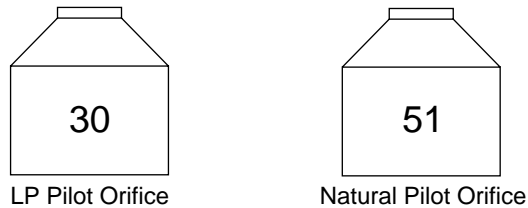

Fig. 20

## GAS CONVERSION

1. Open lower door and locate the 1/4" O.D. tubing connecting the control to the bottom of the pilot.
2. Loosen the nut on the tubing at the pilot completely then gently pull down on the pilot tubing to expose the pilot orifice. (Fig. 21)
3. Remove pilot orifice and put correct orifice for the desired gas on the end of the tubing. (Fig. 21)
4. Reinstall the pilot supply tubing, with orifice, in the base of the pilot and tighten nut.
5. Next, locate the conversion cap on the control and remove it. (Fig. 22)
6. Rotate the conversion cap until the desired gas designation is exposed and reinstall it in the control.
7. Open glass door and remove the ceramic logs.
8. Remove burner screw and then remove burner.
9. Unscrew burner orifice and install orifice for the gas to be used as identified on the unit rating plate. When installing the new orifice you must use a pipe sealant approved for use with Natural and LP gas.
10. Install burner and burner screw.
11. Check for gas leaks at all connections.
12. Replace ceramic logs and close glass door.

Fig. 21



LP Pilot orifice will be color coded BLACK.

Fig. 22

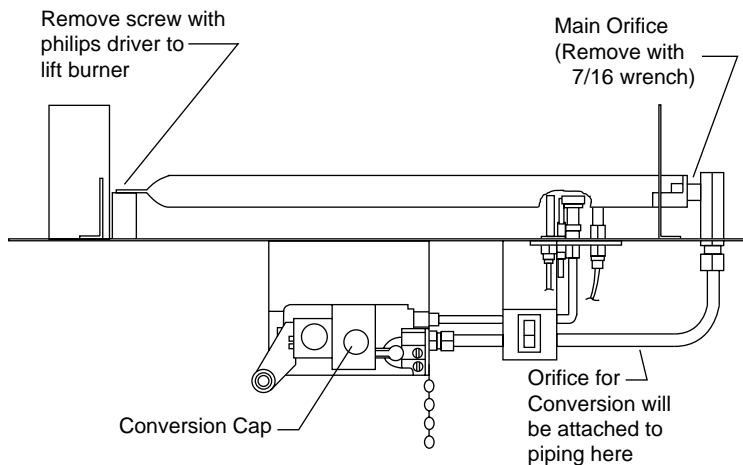

**Warning!** Improper installation, adjustment, alteration, service or maintenance can cause injury or property damage. For assistance or additional information consult a qualified installer, service agency or the gas supplier.

Due to high surface temperatures, keep children, clothing and furniture away.

Keep burner and control compartment clean.

## TROUBLESHOOTING

**PROBLEM:**

Piezo sparker won't light pilot.

**POSSIBLE CAUSES:**

1. Misaligned electrode.
2. Incorrect wire connections.
3. Defective electrode.
4. Defective push button.
5. No gas present.

**REMEDIES:**

1. Realign electrode so it produces spark into pilot hood (approximately 1/8" from pilot hood).
2. Make sure connections are proper.
3. Replace electrode if shorted out or it has cracked porcelain.
4. Replace push button.
5. Turn gas on.

**PROBLEM:**

Pilot will not stay lit.

**POSSIBLE CAUSES:**

1. Incorrect lighting procedure.
2. Pilot flame not making proper contact with thermopile.
3. Bad connection between thermopile and screw terminals on gas valve.
4. Wires on wrong terminals.
5. Thermopile is defective, dirty, or weak.
6. Thermopile is shorting out where it passes through cabinet.
7. Gas valve will not prove pilot.
8. Air in line.
9. Wire from valve to wall switch or remote switch is nicked or shorting out.
10. Switch defective or short in circuit.

**REMEDIES:**

1. Checking lighting instructions found on label in gas fireplace or in owners manual.
2. Adjust pilot (see page 6).
3. Make sure screws are snug holding thermopile. (Do not overtighten or the screws will become stripped).
4. White lead from thermopile must go to top screw TH TP terminal and red wire must go to spill switch wire.
5. Test with millivolt meter and replace if necessary.
6. Replace thermopile.
7. Replace valve.
8. Purge air from gas line.
9. Remove wall switch wires from top and bottom screw of millivolt valve. If unit is OK and you reconnect the wall switch and it cuts out again, then replace wires to wall switch.
10. Replace switch.

**PROBLEM:**

Pilot stays on but main burner won't come on.

**POSSIBLE CAUSES:**

1. Wired incorrectly.
2. Wall switch, on/off switch, or remote hand switch defective.
3. Not enough voltage being generated by pilot.
4. Defective gas control valve.

**REMEDIES:**

1. See page 22 for correct wiring.
2. Replace wall switch, on/off switch, or remote hand switch.
3. Adjust pilot light up to create more voltage or replace thermopile.
4. Replace gas control valve.

**PROBLEM:**

Wall switch must be pushed multiple times to make flame come on.

**POSSIBLE CAUSES:**

Defective wall switch.

**REMEDIES:**

Replace wall switch.  
NOTE: Can use standard single pole electrical switch.

## TROUBLESHOOTING (CONT.)

**PROBLEM:**

Window keeps getting sooty.

**POSSIBLE CAUSES:**

Unit needs more primary air.

1. Blocked primary air port.
2. Flame impingement on logs or elsewhere.
3. Logs too close to or touching glass.
4. Valve and burner over-fired.

**REMEDIES:**

1. Check primary air assembly. Over a period of time dust, lint, pet hair, etc. can plug primary air hole. Clean out.
2. Reposition logs or adjust flame.
3. Move logs to allow at least 3/8" clearance from logs to glass.
4. Check the amount of flow with monometer, and adjust regulator if necessary.

**PROBLEM:**

Dirty window. (White on window).

**POSSIBLE CAUSES:**

Initial burn off of paint and sealants used to produce unit.

**REMEDIES:**

1. Clean window using AJAX or COMET, and paper towel.
2. Dissolve powder AJAX or powder COMET in water on window. Clean in small circular motions. Rinse thoroughly and reinstall in unit. **DO NOT USE ANY LIQUID CLEANERS ON WINDOW.** It will burn black on window when reinstalled.

NOTE: Windows are made of neo (pyro) ceramic, NOT glass. Because of this, they will handle temperatures in excess of 1,200 degrees Fahrenheit constant temperature. The window only reaches between 500-600 degrees Fahrenheit. Because of this it is almost impossible to bake something into the window. Most things will, with a little effort, come off if you follow these directions.

**PROBLEM:**

Circulating fan speed does not vary.

**POSSIBLE CAUSES:**

Variable speed rheostat defective.

**REMEDIES:**

Replace rheostat.

NOTE: Only replace rheostat with a rheostat supplied by United States Stove Company. Light dimmer switches or incorrect rheostats will burn out the fan motor. This will void the warranty of the fan.

**PROBLEM:**

Fan makes humming sound, but won't come on.

**POSSIBLE CAUSES:**

1. Rheostat needs adjustment.
2. Fan impellers dirty.
3. Fan defective.

**REMEDIES:**

1. Adjust variable speed control.
2. Clean fan.
3. Replace fan.

NOTE: Make sure the fan plug-in cord is not nicked by decorative trim kits. This could cause the fan to short out and also damage the gas valve.

**PROBLEM:**

Fireplace not venting.

**POSSIBLE CAUSES:**

1. Venting blocked.
2. Improper venting installation.

**REMEDIES:**

1. Remove blockage.
2. Check all venting connections for proper fit.



## TURNING GAS OFF TO APPLIANCE



1. Set the thermostat to lowest setting.
2. Turn off all electric power to the appliance if service is to be performed.
3. Push in gas control knob slightly and turn clockwise to "OFF". Do not force. 



## FOR YOUR SAFETY READ BEFORE LIGHTING

**WARNING:** If you do not follow these instructions exactly, a fire or explosion may result causing property damage, personal injury or loss of life.

- A. This appliance has a pilot which must be lighted by a piezo ignitor. When lighting the pilot, follow these instructions exactly.
  - B. BEFORE LIGHTING smell all around the appliance areas for gas. Be sure to smell next to the floor because some gas is heavier than air and will settle on the floor. **WHAT TO DO IF YOU SMELL GAS:**
    - Do not try to light any appliance.
    - Do not touch any electric switch; do not use any phone in your building.
    - Immediately call your gas supplier from a neighbor's phone. Follow the gas supplier's instructions.
  - C. Use only your hand to push in or turn the gas control knob. Never use tools. If the knob will not push in or turn by hand, don't try to repair it, call a qualified service technician. Force or attempted repair may result in a fire or explosion.
  - D. Do not use this appliance if any part has been under water. Immediately call a qualified service technician to inspect the appliance and to replace any part of the control system and any gas control which has been under water.
- If you cannot reach your gas supplier, call the fire department.



## LIGHTING INSTRUCTIONS



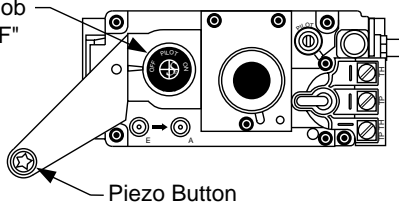

1. STOP! Read the safety information above on this label.
2. Set the thermostat to lowest setting.
3. Open lower door.
4. Turn off all electric power to the appliance.
5. Push in gas control knob slightly and turn clockwise  to "OFF".

Gas Control Knob Shown in "OFF" Position



**NOTE:** Knob cannot be turned from "PILOT" to "OFF" unless knob is pushed in slightly. Do not force.

6. Wait five (5) minutes to clear out any gas. Then smell for gas, including near the floor. If you smell gas, STOP! Follow "B" in the safety information above this label. If you don't smell gas, go to the next step.
7. Find pilot. The pilot is between the two ceramic logs, behind the burner.
8. Turn knob on gas control counterclockwise  to "PILOT".
9. Push in control knob all the way and hold in. Immediately light the pilot by pushing in on the piezo button. Continue to hold the control knob in for about one (1) minute after, the pilot is lit. Release knob and it will pop back up. Pilot should remain lit. If it goes out, repeat steps 5 through 9.
10. Turn gas control knob counterclockwise  to "ON"
11. Turn on all electric power to the appliance.
12. Set thermostat to desired setting.
13. Close lower door.

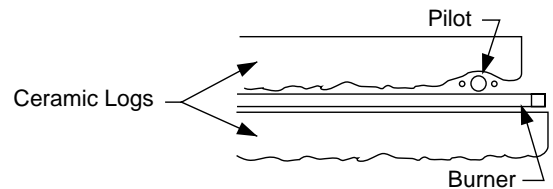

If the knob does not pop up when released, stop and immediately call your service technician or gas supplier.

If the pilot will not stay lit after several tries, turn the gas control knob to "OFF" and call your service technician or gas supplier.

851181

# MODEL 9660 GENERATOR REPAIR PARTS

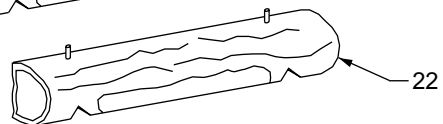
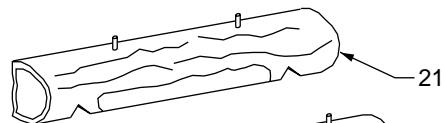
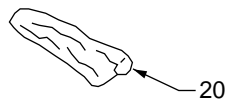
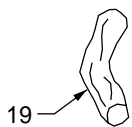
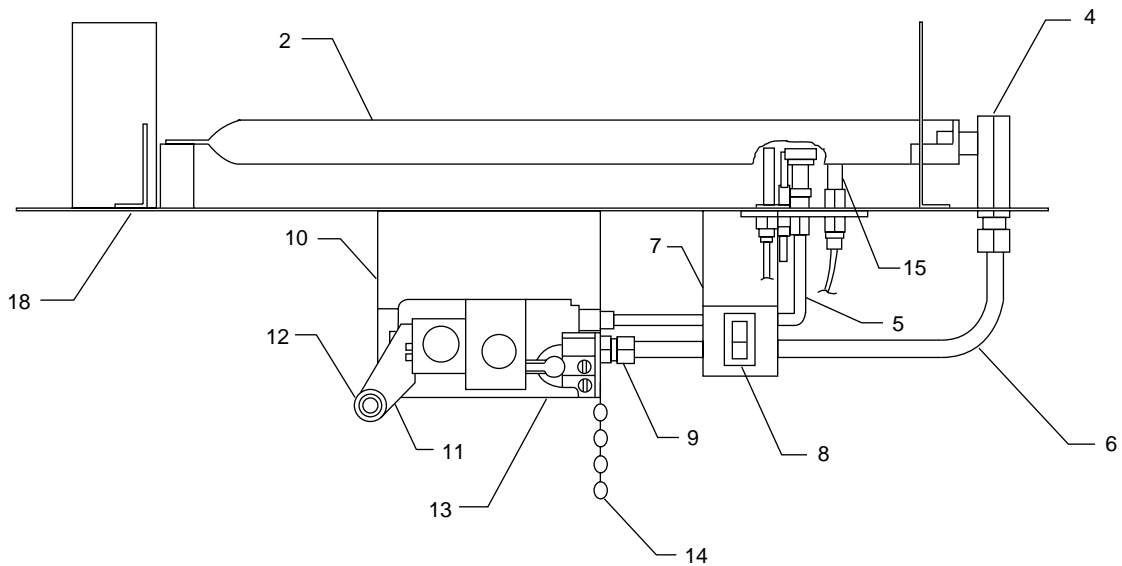
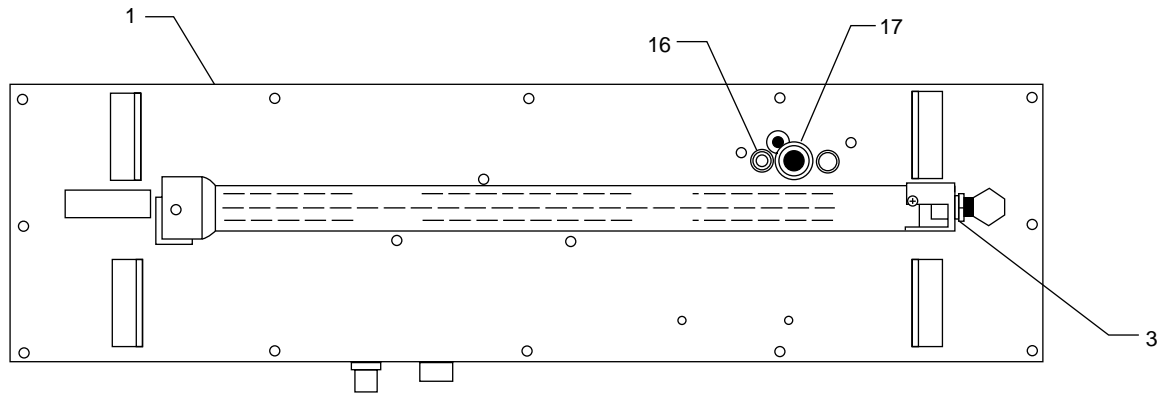

## MODEL 9660 GENERATOR PARTS LIST

ITEM	DESCRIPTION	PART #	QUANTITY
1	Control Plate Weldment	68984	1
2	Burner	89764	1
3	L.P. Burner Orifice	81185	1
*	Natural Gas Burner Orifice	81184	1
4	Manifold Union	89762	1
5	1/4" OD Flex Tube	86541	1
6	3/8" OD Flex Tube	86542	1
7	Switch Bracket	24262	1
8	Rocker Switch	C42373	1
9	Adaptor Fitting	81183	1
10	Control Bracket	24241	1
11	Piezo Bracket w/Screw	89760	1
12	Piezo w/ Nut	89761	1
13	Sit Control	81182	1
14	16ga. Link Chain	86318	1 FT.
15	Thermopile	C43815	1
16	Sit Thermo-Couple	89759	1
17	L.P. Sit Pilot	89757	1
*	Natural Gas Sit Pilot	89758	1
18	Generator Gasket	88086	1
*	#8 x 1/2" Teks	83437	8
*	Piezo Cable	80375	1
*	Wire Assembly	80376	1
*	10-32 x 3/8 Machine Screw	83464	4
19	Top Fork Log	89771	1
20	Top Twig Log	89772	1
21	Rear Log	89770	1
22	Front Log	89769	1
*	Natural Pilot Orifice	81186	1
*	L.P. Pilot Orifice	81187	1

\* NOT SHOWN

# MODEL 9660 GAS FURNACE REPAIR PARTS

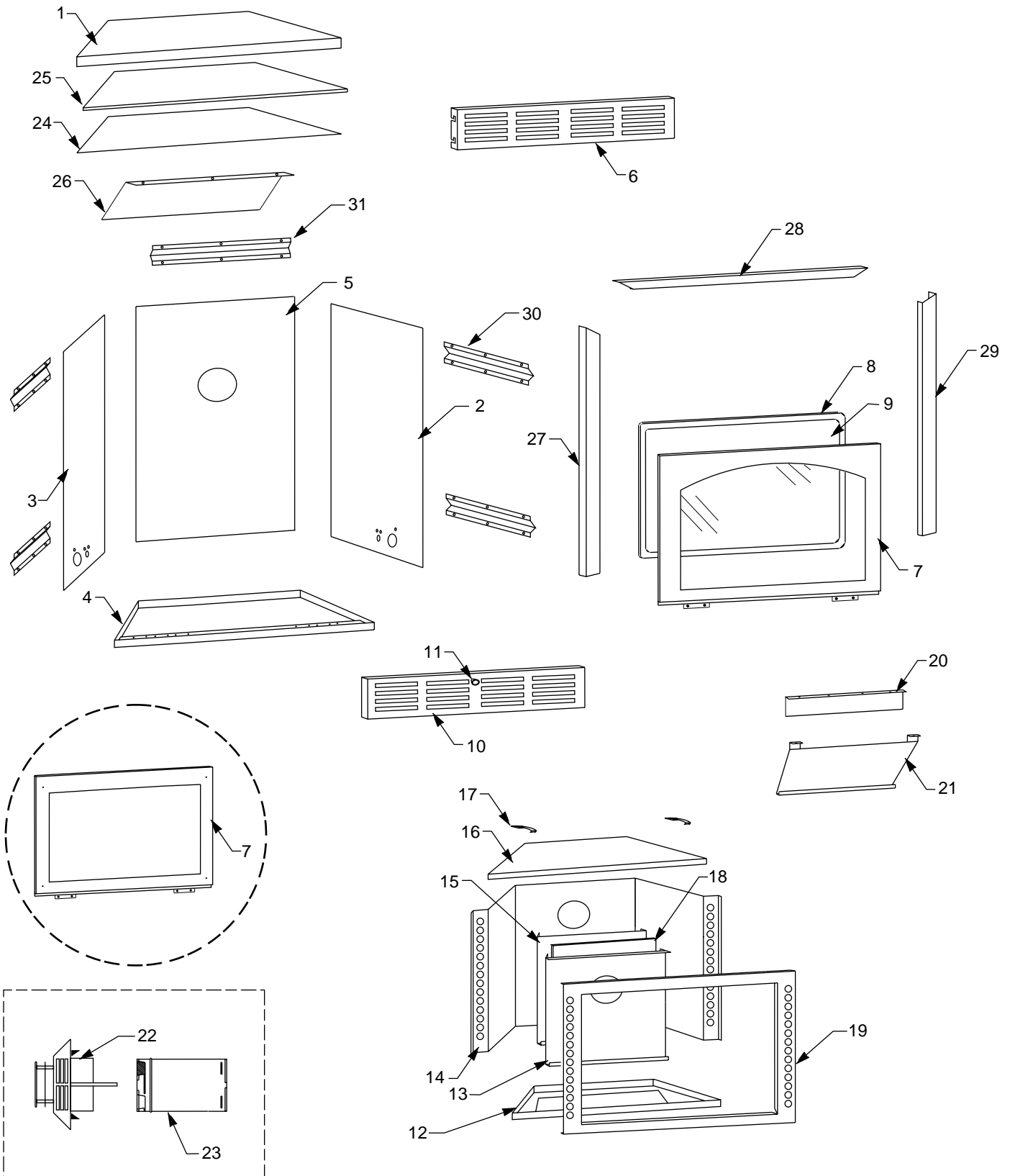

## MODEL 9660 GAS FURNACE PARTS LIST

ITEM	DESCRIPTION	PART #	QUANTITY
1	Unit Top	24249	1
2	Unit Right Side	24242	1
3	Unit Left Side	24243	1
4	Unit Base	24255	1
5	Unit Back	24246	1
6	Top Grill	24261	1
7	Arched Door Frame	68986	1
	Full-view Door Frame	69046	1
8	1-1/4" Flat Rope	88087	8.042Ft.
9	Glass	89763	1
10	Lower Grill	24260	1
11	Brass Door Knob	89336	1
*	10-32x1/2" Machine Screw	83115	1
*	Lower Grill Hinge	C18513	2
12	Firebox Bottom	24259	1
13	Firebox Divider	24250	1
*	Flue Outlet	89754	1
14	Firebox Wrapper	24253	1
*	Starting Collar	89756	1
15	Firebox Shield	24265	1
16	Firebox Top	24258	1
17	Latch w/ Keeper	89755	2
18	Insulation	24266	1
19	Firebox Front	24251	1
20	Inner Baffle	24279	1
21	Baffle Plate	24252	1
22	Vent Termination Assembly	68997	1
23	12" CO-AX Pipe	89765	1
24	Insulation Shield	24269	1
25	Top Insulation	24270	1
26	Air Deflector	24280	1
27	Left Side Trim	89748	1
28	Top Trim	89749	1
29	Right Side Trim	89747	1
30	Side Standoff (2xLeft side, 2xRight side)	24278	4
31	Rear Standoff	24283	2
*	Vent Standoff	24272	4

\* NOT SHOWN

**OPTIONAL KITS AVAILABLE**

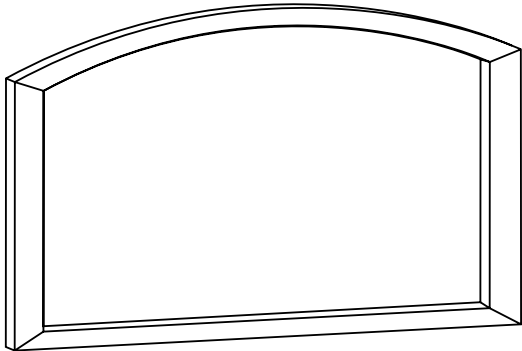

**MODEL: BDK60  
BRASS DOOR TRIM KIT**

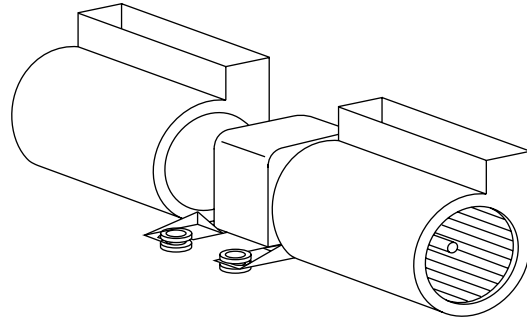

**MODEL: B60  
BLOWER KIT**

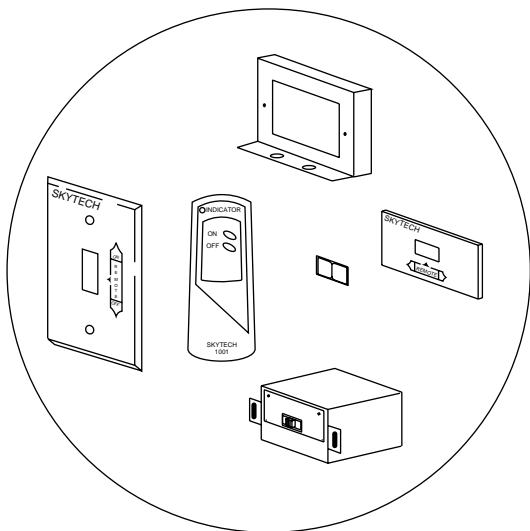

**MODEL: RCK60  
REMOTE CONTROL KIT**

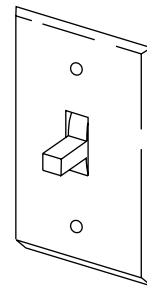

**MODEL: WSK60  
WALL SWITCH KIT**



**MODEL: WTK60  
WALL THERMOSTAT KIT**

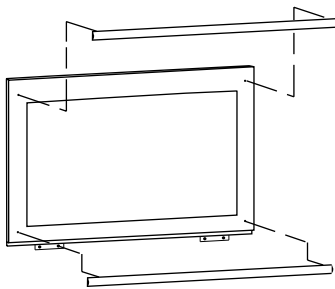

**MODEL: FVK60  
FULL-VIEW DOOR KIT**

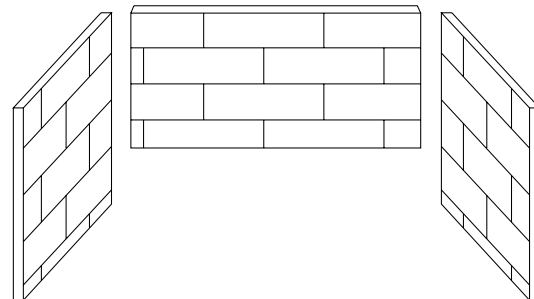

**MODEL: CBK60  
REFRACTORY CERAMIC BRICK KIT**

## WIRING DIAGRAM FOR OPTIONAL (MODEL #B60) BLOWER KIT

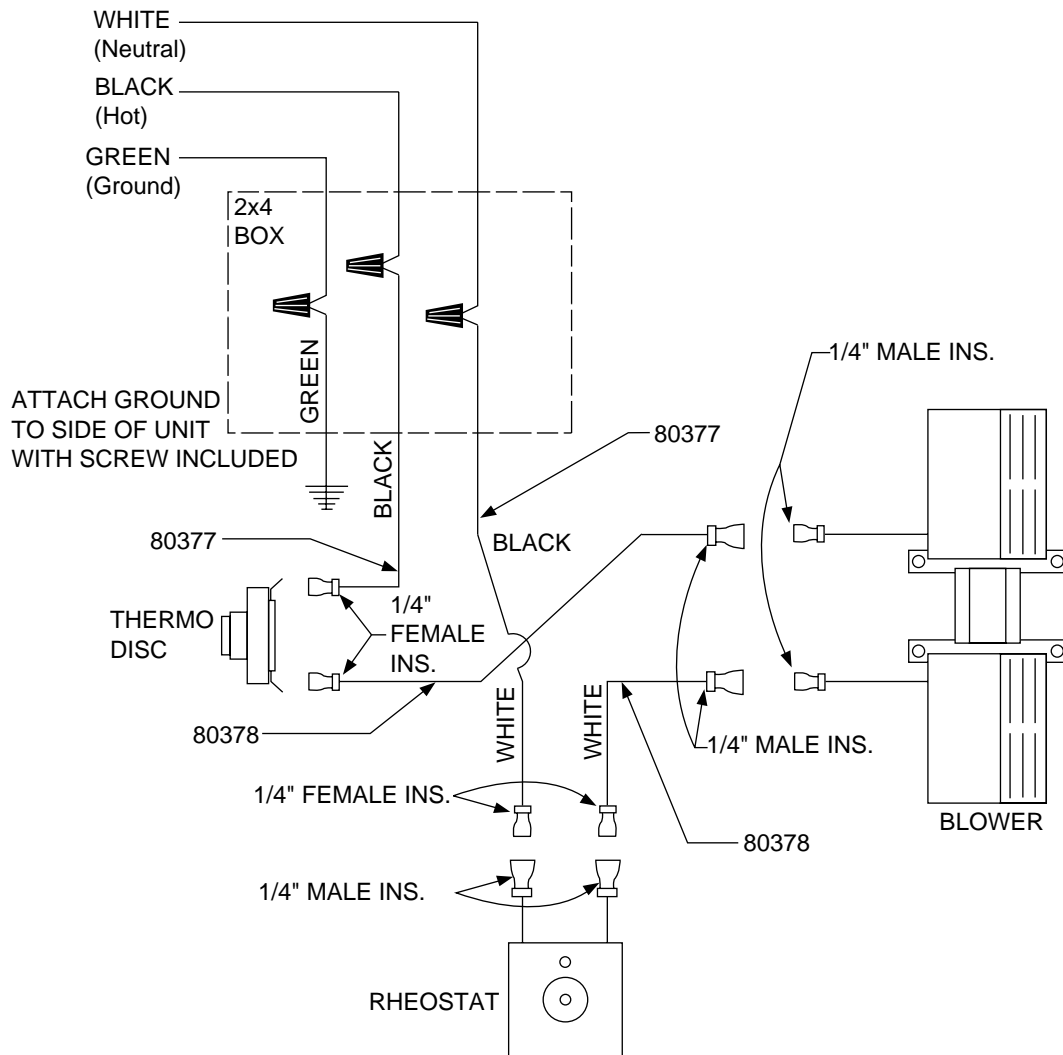

## WIRING DIAGRAM FOR GENERATOR ASSEMBLY

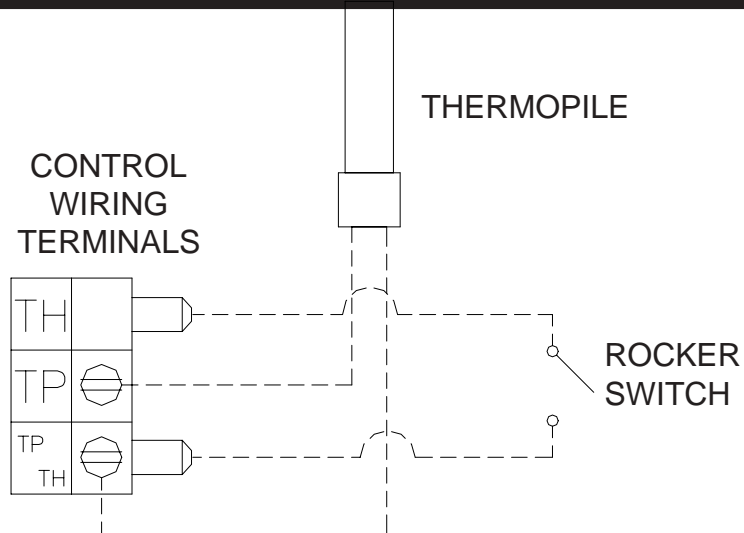

## WIRING GUIDE FOR 9660

The following Wiring Guide is to help assist in the wiring of any combination of the Optional Kit listed below:

RCK60 - REMOTE CONTROL KIT  
WSK60 - WALL SWITCH KIT  
WTK60 - WALL THERMOSTAT KIT

**IMPORTANT:** Before ordering or installing any to the available kits, remember the following...

- 1) Not all Optional Kits will work together. Example: The (RCK60) Remote Control Kit, the (WSK60) Wall Switch Kit, and the (WTK60) Wall Thermostat Kit cannot be used at the time.
- 2) When using any of the three Optional Kits listed above, the Rocker Switch on the unit must be set to "OFF".
- 3) If you choose to use any combination of the above Optional Kits, only one of those kits can be used at a time. Example: If you have the Optional Remote Control Kit and the Optional Wall Switch Kit, operation of the unit must be controlled by one or the other. If you want to use the remote control, simply turn the Wall Switch to "OFF".

### STANDARD WIRING FROM FACTORY:

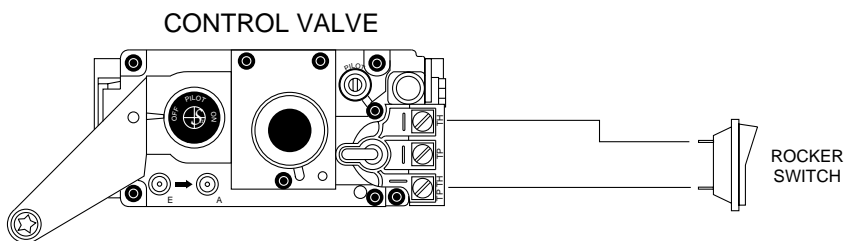

### WIRING OF THE RCK60 - REMOTE CONTROL KIT:

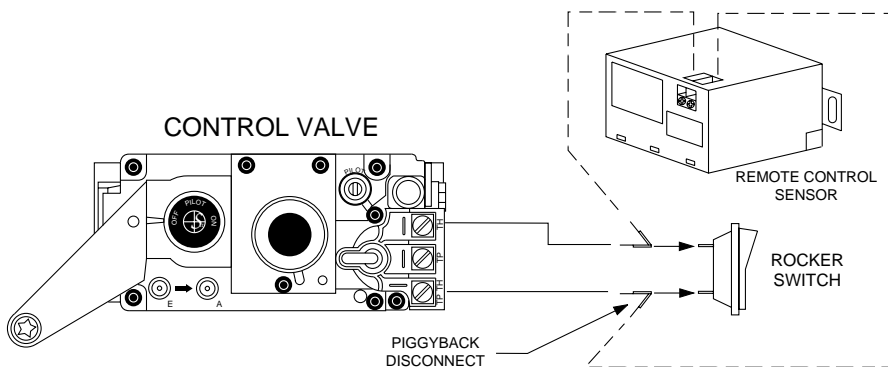

Remember the Rocker Switch must be turned to "OFF" while using the Remote Control.

### WIRING WITH THE WTK60 - WALL THERMOSTAT KIT:

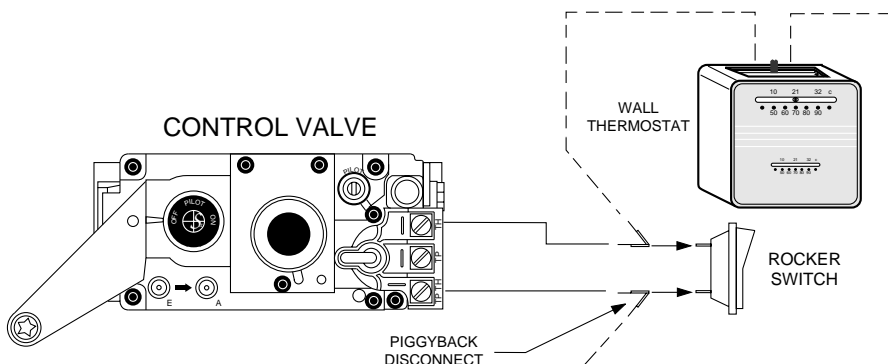

Remember the Rocker Switch must be turned to "OFF" while using the Wall Thermostat.

## WIRING WITH THE WSK60 - WALL SWITCH KIT:

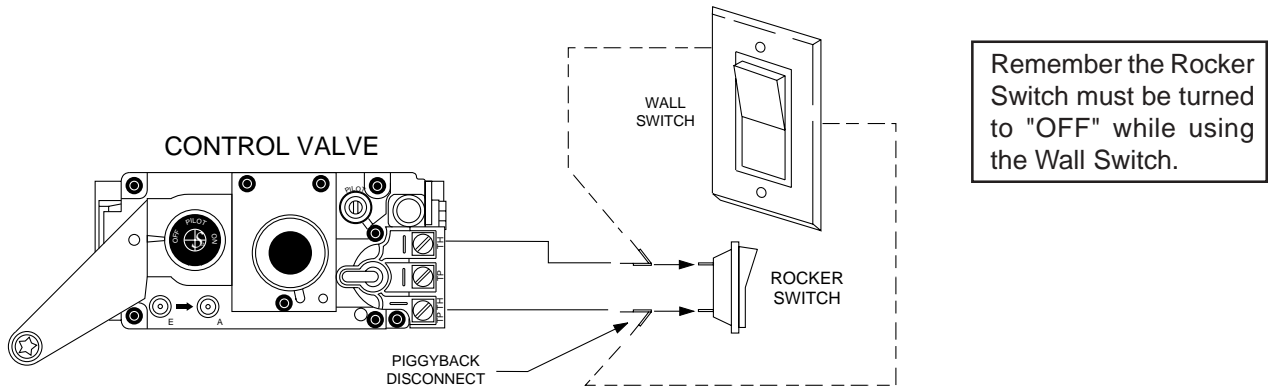

## WIRING WITH THE WTK60 - WALL THERMOSTAT KIT AND THE RCK60 - REMOTE CONTROL KIT:

Note: When combining these Optional kits, only one kit can be used at a time. Example: If you want to control the operation of this unit with the Remote Control then you must turn the Wall Thermostat "OFF". When trying to use two Optional kits at once, one will always override the other.

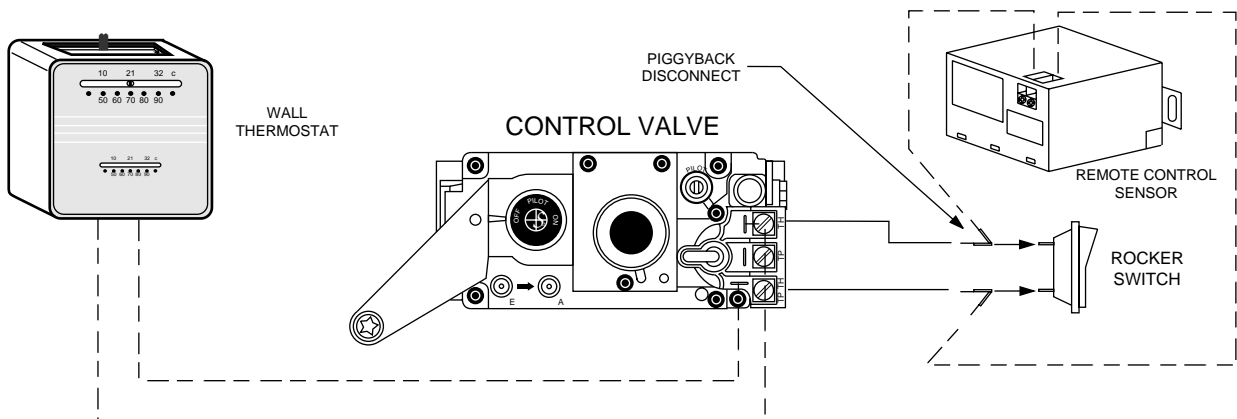

## WIRING WITH THE WSK60 - WALL SWITCH KIT AND THE RCK60 - REMOTE CONTROL KIT:

Note: When combining these Optional kits you must remember that only one of them can be used at a time. Example: If you want to control the operation of this unit with the Remote Control then you must turn the Wall Switch "OFF". When trying to use two Optional kits at once, one will always override the other.

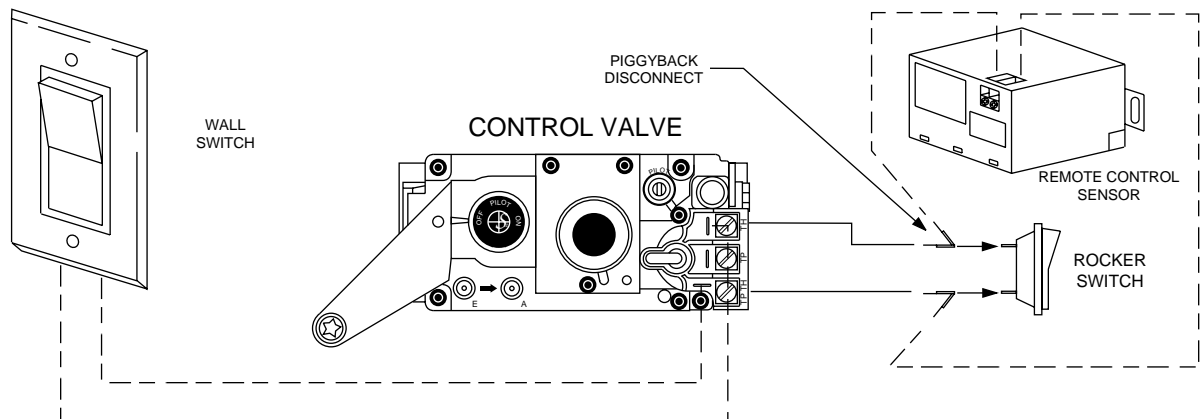

For further information, contact our Customer Service Department at United States Stove Company, 227 Industrial Park Road, P.O. Box 151, South Pittsburg, Tn. 37380. (423)837-2100

## NOTES

## NOTES

## HOW TO ORDER REPAIR PARTS

**THIS MANUAL WILL HELP YOU OBTAIN EFFICIENT, DEPENDABLE SERVICE FROM YOUR 9660 GRAVITY TYPE VENTED WALL FURNACE, AND ENABLE YOU TO ORDER REPAIR PARTS CORRECTLY.**

**KEEP THIS MANUAL IN A SAFE PLACE FOR FUTURE REFERENCE.**

**WHEN WRITING, ALWAYS GIVE THE FULL MODEL NUMBER WHICH IS ON THE NAMEPLATE ATTACHED TO THE HEATER.**

**WHEN ORDERING REPAIR PARTS, ALWAYS GIVE THE FOLLOWING INFORMATION AS SHOWN IN THIS LIST:**

- 1. THE PART NUMBER**
- 2. THE PART DESCRIPTION**
- 3. THE MODEL NUMBER: 9660**
- 4. THE SERIAL NUMBER: \_\_\_\_\_**



**UNITED STATES STOVE COMPANY  
227 INDUSTRIAL PARK ROAD  
PO BOX 151  
SOUTH PITTSBURG, TN 37380  
(423) 837-2100**

